



In our industry, there's nothing wrong with being predictable.

AI-Tek **Speed Sensors** >> **Tachometers** >> **Accessories**



AI-TEK Instruments, LLC.

152 Knotter Drive • PO Box 748
Cheshire, CT 06410

www.aitekinstruments.com



Table of Contents

Tachometers

STACKTACH Single Input Industrial Tachometer	4
Tach•Pak® 1 Digital Process Speed Switch	7
Tach•Pak® 3 Digital Process Tachometer	10
Tachtrol® 3 Dual Input Digital Tachometer	13
Enclosure Options	16

Sensors

Principles of Operation of VR Sensors	21
Magnetic Sensor Selection	22
Calculation of Output Voltage	23
Passive Speed Sensors, VR Types	24 - 35
Side Look Sensors	36
Hall Effect Sensors	39 - 45
Bi-Directional, Dual Channel, Hall Effect Sensors ..	46 - 49

Accessories

Connectors and Cable Assemblies	50
Split and Solid Gears	52
Tachometer Transducers	54
Sensor Mounting Brackets	56
Part Number Index	Inside Back Cover



Introduction to AI-Tek Instruments, LLC

AI-Tek Instruments designs and manufactures speed sensors and tachometer products which protect and monitor rotating equipment. AI-Tek Instruments is committed to provide the highest quality products it can, at competitive prices, through its ISO 9001 certified quality system. This commitment is the reason we have enjoyed over 50 years of continuous service to our customers.

Formerly known as Airpax Instruments as part of Philips North America Corporation, it was sold to VDO Control Systems, Inc. in 1998 who sold the Airpax Instruments portion of the business to AI-Tek Instruments, LLC in 2001.

With our many years of experience, we at AI-Tek Instruments look forward to providing you with improved levels of service and products and with continuous growth, domestically and internationally, in the years to come.

About AI-Tek® Tachometers

Not all tachometers are the same, and this is certainly true of the AI-Tek Instruments tachometry line.

Designed with severe industrial environments in mind, these units will provide reliable around-the-clock operation for years under adverse conditions.

AI-Tek Instruments is a leader in manufacturing this type of instrument.

Our prices reflect the design, quality, ruggedness and engineering of the equipment. What you really get with AI-Tek Instruments is a superb price-performance ratio. It may not initially be the least expensive equipment available but, in the long run, the value of this equipment is that it will outperform and outlast others.

It is the customer's responsibility to determine whether the product is proper for customer's use and application.

The information contained herein is subject to change without notice. Refer to the factory for verification of any details.



STACKTACH Single Input Industrial Tachometer

(New)
CE Compliant
Part Number Series T77410

Precisely What You Need AI-Tek's New STACKTACH

AI-Tek is pleased to introduce a new tachometer to meet today's requirements for compact packaging. Using the same highly reliable and quality design customers have come to depend on, AI-Tek now makes a tachometer available in a .9" thick (22.5mm) DIN rail mount package. Easily programmed through a hand held pendant, the STACKTACH's Analog Output can be set for 0-20 or 4-20 mA range for the precise scale you need. The 6 Amp, 300 Vac, C-form relay can be set for the exact speed and hysteresis required for your application.

Features and Advantages

Designed to meet the latest European standards, the STACKTACH is mounted in a rugged IP40 rated enclosure and has been fully tested to the following standards.

- *EMC - Electromagnetic Compatibility:* complies to CE per EMC Directive 89/336/EEC. Immunity per EN 50082-2, 1995 Emission per EN 50081-2, 1995.
- *Vibration:* Meets IEC 68-2-6, 10 to 150 Hz, 2g.
- *Shock:* Meets IEC 68-2-27, 50g half sine

Powered by 24 Vdc, AI-Tek can also provide a switching power supply, capable of powering as many as three STACKTACHs. This power supply is UL, CSA and DIN VDE listed and CE compliant.

- Fast response overspeed shutdown
- PLC control input
- Petrochemical production
- Pump or generator alarm
- Low speed tachometer
- Expanding analog scale speed transmitter
- Start-up, over/under speed switching
- Textile production applications
- RPM measurement
- Paper and pulp production
- Turbine speed control input
- Metal production
- Mining applications
- Frequency measurement
- Test labs
- Generator sets
- Food processing
- Conveyor protection
- Printing industry

Applications

Ordering P/N	Description	Weight
T77410-10	STACKTACH using 24 Vdc supply,	6 oz.
T77410-P	(1) Analog Output, (1) 6 Amp Relay	8 oz.
T77410-100/240AC	Programming Pendant Switching Power Supply - able to convert 100 Vac thru 240 Vac. 50-60 Hz input to 24 Vdc output.	5 oz.

It is the customer's responsibility to determine whether the product is proper for customer's use and application.

Specifications

Signal Input

Type: Active or passive pickup determined by software settings (jumper required for active pickups)

AC Input (sine wave):

Input Impedance = 2000 ohms
Sensitivity @ 1KHz = 250 Vrms
Max. Voltage Input = 25 Vrms

Pulse Input (TTL compatible):

Input Impedance = 2000 ohms
Min. Pulse Width = 10 μ S
Logic 0 = V in < .5V
Logic 1 = V in > 1.5V

(+ 12 VDC @ 50mA supplied for-powered sensors)

Frequency Range: Upper limit 30 kHz. Lower limit software selectable from .0625 Hz to 10 Hz.

Input Power*

24 Vdc (24-30 V), std. 600 ohm analog load. 7 watts max. power.

*A switching power supply, P/N T77410 - 100/240 AC, is available. It converts 100 Vac thru 240 Vac, 50/60 Hz input power to 24 Vdc output.

Output

Relay Output: One SPDT relay, rated 6 amps @ 28 Vdc or 300 Vac, 170 W or 1800 VA. Frequency hysteresis selectable from 0.0% to 99.9%, or

latching with remote reset. Relay logic and type selectable. Time hysteresis selectable 000 to 99 data acquisitions or latching with delay of 000 to 999 data acquisitions.

Analog Output: Selectable from 0 to 20 mA or 4 to 20 mA \pm 5%. True current, 600 ohm maximum loop resistance. Full scale and zero scale selectable from 0 Hz to 30 kHz.

Response: 50 millsec. updates above 100 Hz. See manual for updates between 20 and 100 Hz, one cycle below 20 Hz.

Accuracy: \pm 0.05% for relay setpoints in operations over temperature range, \pm 0.5% of full scale for analog outputs.

Environmental

Temperature: -10°C to 55°C operating. -40°C to 80°C storage.

Vibration: Tested to IEC 68-2-6, 10-150 Hz, 2g.

Shock: Tested to IEC 68-2-27 50g half sine.

Enclosure: IP 40

Humidity: Tested to IEC 654-1, IEC 68-2-3 90% Humidity.

Constant Storage: Retained in EAROM and may be altered 1,000,000 times.

Electrical References: DC power is referenced to digital common. Analog output is referred to analog output common. Passive inputs are balanced. Active pickup inputs are referenced to circuit common. Form C relay contacts are isolated.

Electromagnetic Compatibility: The STACKTACH shall function to the requirements of the European Council Directive 89/336/EEC, the EMC Directive.

IMMUNITY per EN 50082-2 1995:

EN61000-4-2, 1995: ESD: \pm 8kV Air, \pm 4kV contact discharge.

EN61000-4-3, 1997: Radiated R-F: 10 V/m, 80 to 1000 MHz.

ENV50204, 1995: Radiated pulsed: 10 V/m, 900 MHz.

EN61000-4-4, 1994: EFT/B: 2 kV

ENV50141: Conducted noise: 10V, 150 KHz to MHz.

EN61000-4-8, 1994: Power frequency, magnetic field: 1 A/m.

EMISSION per EN50081-2 1995:

EN55011, 1998: Class B radiated emissions.

Terminal Block #	Terminal	Description
TB1	1	Input Signal +
TB1	2	Input Signal -
TB1	3	Shield
TB1	4	+12 Vdc Output (50 mA max.)
TB2	5	0-20/4-20 mA Analog Output (+)
TB2	6	0-20/4-20 mA Analog Output (-)
TB2	7	Verify/Calibrate (when connected to +12 Vdc)
TB2	8	Digital Common
TB3	9	Digital Common
TB3	10	+24 Vdc Input
TB3	11	Relay Resent (when connected to Digital Common)
TB3	12	Earth
TB4	13	K1 Common
TB4	14	No Connection (not used)
TB4	15	K1 Normally Closed
TB4	16	K1 Normally Open

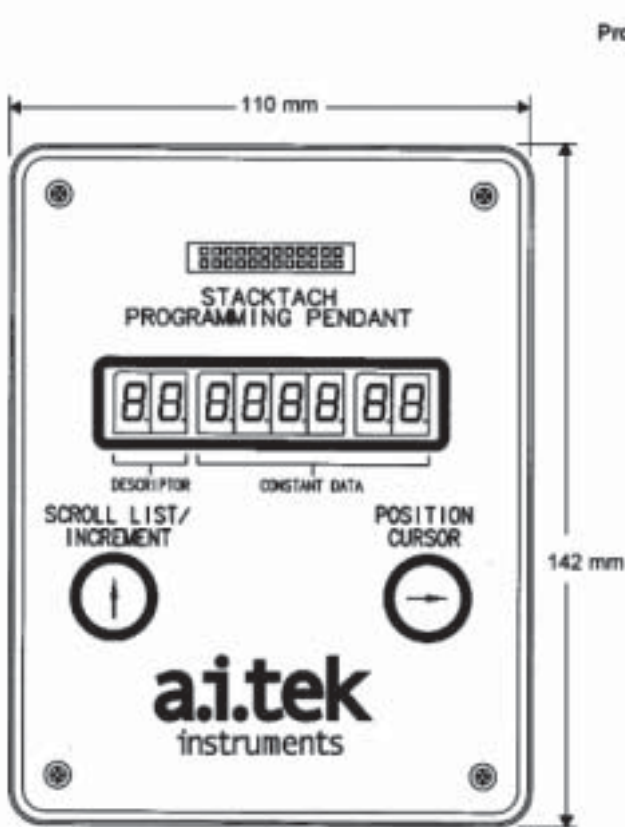
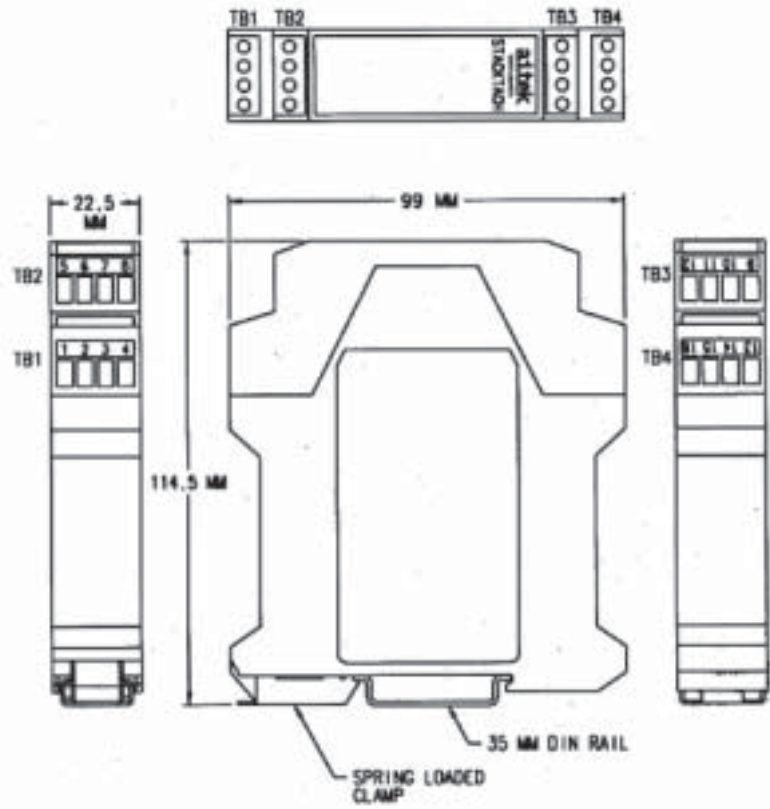

Programming Pendant

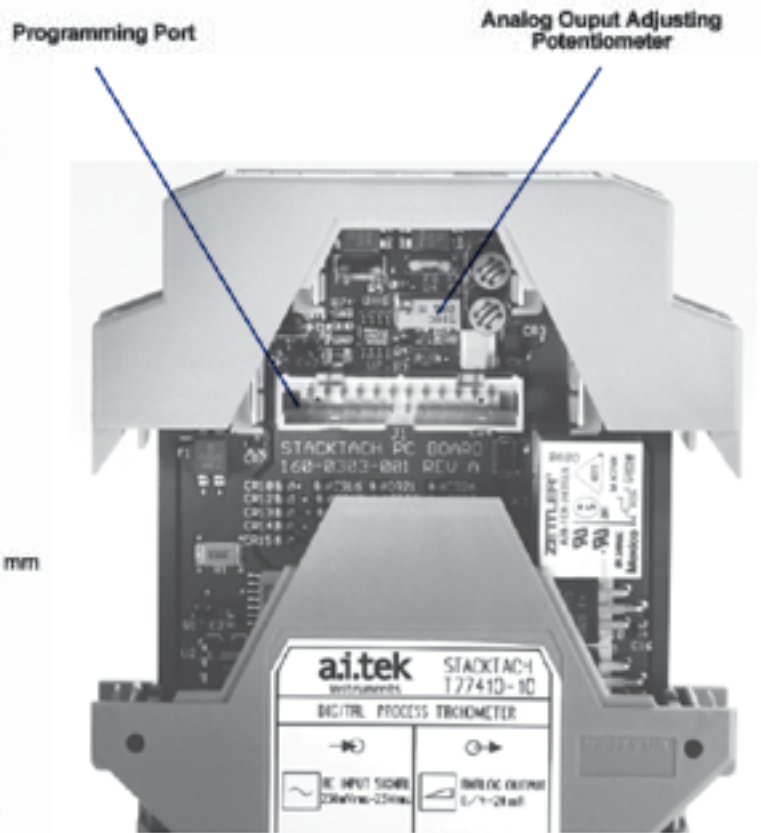

TACH•PAK® 1

Digital Process Tachometer

(Speed Switch Only)
 CSA Listed
 Part Number Series T77130



Faster - More Accurate - Field Programmable

The **Tach•Pak 1** computing speed switch is a single channel instrument. It measures input frequency and converts the resulting quantities to relay closure.

The microcomputer-based Tach•Pak 1 speed switch uses adaptive period averaging which permits a combination of fast response and high accuracy not available in other industrial speed instruments. The instrument functions can easily be programmed in the field or altered at any time using a unique internal switch design.

Typically, a Tach•Pak 1 speed switch is used with magnetic sensors as a signal source. However, it may receive a sine wave or TTL signal from any frequency source. The resulting speed is used for alarm switching. It is superior in applications requiring fast update times and high accuracy for equipment protection.

Features and Advantages

- Quicker Response Time* - 50 millisecond updates above 100 Hz.
- Higher Level of Accuracy* - $\pm .05\%$ for relay setpoints in operation over temperature ranges.
- Field Programmable* - Adaptable to various applications and requirements by utilizing a unique internal switch design. No additional calibration equipment is required.
- Digital Configuration* - Utilizes adaptive period averaging and floating point calculation.
- 2 Relays* - Sealed 6 amp SPDT auto reset or latching.
- AC or DC Power* - Adaptable to either AC or DC power source.

Applications

- Fast response overspeed shutdown
- Petrochemical production applications
- Pump or generator alarm
- Low speed switching
- Start-up, over/under speed switching
- Textile production applications
- Machine control
- Paper and pulp production
- Turbine speed control
- Food processing
- Conveyor alarms
- Printing industry
- Metal production
- Mining applications
- Test labs
- Generator sets
- Broken or slipping belt drives

It is the customer's responsibility to determine whether the product is proper for customer's use and application.

Ordering P/N	Input Power	Enclosure	Net Weight (lbs.)
T77130-11	120 Vac/24 Vdc	Standard NEMA 1	2.5
-12	240 Vac/24 Vdc	Standard NEMA 1	2.5
-41	120 Vac/24 Vdc	NEMA 4X *	5.7
-42	240 Vac/24 Vdc	NEMA 4X *	5.7
-71	120 Vac/24 Vdc	Explosion Proof **	39.0
-72	240 Vac/24 Vdc	Explosion Proof **	39.0

* See page 16 for dimensions
 ** See page 17 for dimensions

Specifications

Signal Input

Type: Software selectable for passive or active sensors & terminal block jumper for active sensors.

AC Input (sine wave):

Input Impedance = 2K ohms
 Sensitivity @ 1KHz = 200 mVrms
 Max. Voltage Input = 25 Vrms
 CMRR = > 40 db @ 1KHz, ref. to input amplifier threshold.

Pulse Input (TTL compatible):

Input Impedance = 2K ohms
 Min. Pulse Width = 10 μs
 Logic 0 = V in < .5V
 Logic 1 = V in > 1.5V
 (+ 12 VDC @ 50mA supplied for powered sensors)

Frequency Range: Upper limit 30 KHz. Lower limit software selectable 10 Hz to .0625 Hz.

Power Supply

120 Vac ±10%, 50-60 Hz
 24 Vdc (20-30 V)
 15 watts maximum power.

Output

Relay Output: Two SPDT relays, 6A @ 28 Vdc or 240Vac, 170 W or 1800 VA. Selective relay logic: Energize or de-energize above or below setpoint. Auto-reset at setpoint with programmable frequency hysteresis 00.0% to 99.9% or with time delay hysteresis selectable 000 to 999 data acquisitions. Latching relay at setpoint with remote reset.

Response: 50 millisecond updates above 100 Hz. See manual for updates between 20 and 100 Hz, one cycle below 20 Hz.

Accuracy: ±0.05% for relay setpoints in operation over temperature range.

Environmental

Temperature: -10°C to 55°C operating
 -40°C to 80°C storage

Vibration: Designed to meet MIL-810C, Method 514.2, Procedure VIII, Figure 514.2-6. Curve V (1.5 g's 10-200 Hz).

Shock: Designed to meet MIL-810C, Method 516.2, Procedure I, Figure 516.2-2 for ground equipment (30 g's half sine).

Enclosures Available: NEMA 1 STD, NEMA 4X and Explosion Proof.

Humidity: 90% relative and non-condensing.

Constant Storage: Retained in EAROM and may be altered 1000 or more times.

Electrical References: Circuit common is isolated from AC power, AC ground and case. DC power is referenced to circuit common. Passive inputs are balanced. Active sensor inputs are referenced to circuit common.

Electrical Connections	
TB1 -1 K1 NC -2 K1 COM -3 K1 NO -4 K2 NC -5 K2 COM -6 K2 NO -13 AC Power -14 AC Power -15 Earth	} Relays shown de-energized. Contact rating: 6A max. at 28 Vdc or 6A max. at 240 Vac.
TB2 -1 + 24 Vdc In -2 DC Common -3 Calibrate (when tied to +12V) -4 DC Common -5 + 12Vdc Out (50mA max.) -6 Relay reset (when tied to + 12V) -7 Signal + -8 Signal - -9 Shield	

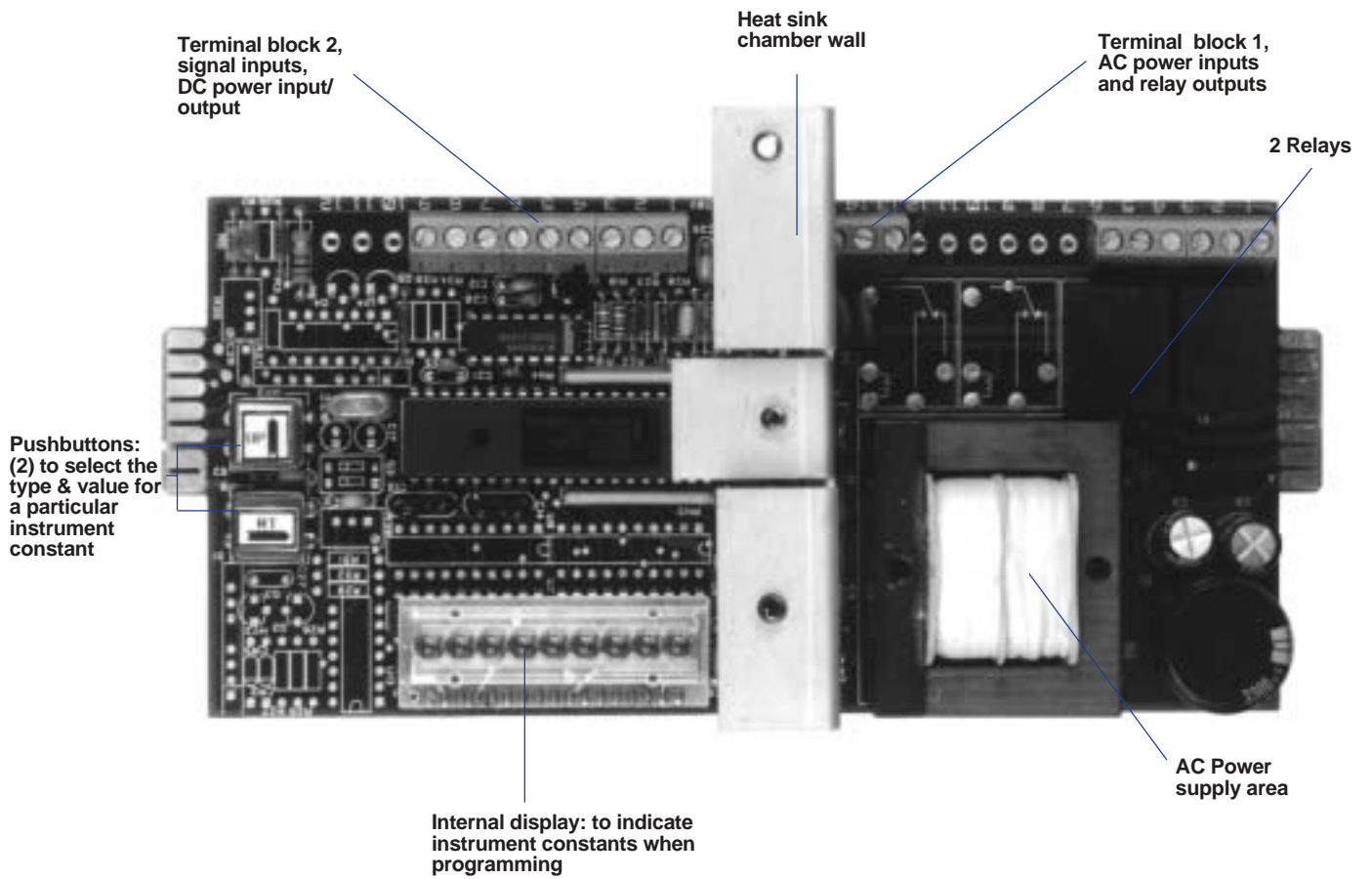
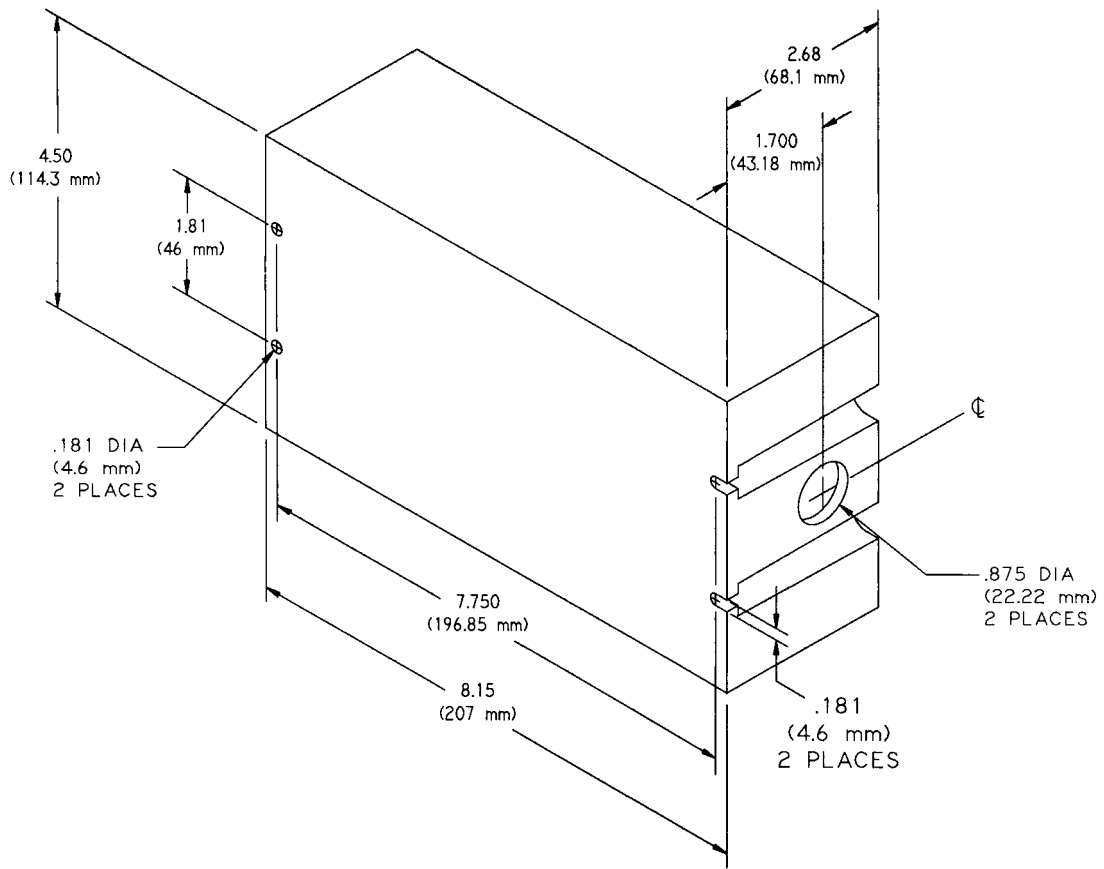

TACH•PAK® 3 Digital Process Tachometer

CSA Listed
Part Number Series T 77430



Faster - More Accurate - Field Programmable

The **Tach•Pak 3** computing tachometer is a single channel instrument. It measures input frequency and converts the resulting quantities to a meter output, an analog output and four relays.

The microcomputer-based Tach•Pak 3 tachometer uses adaptive period averaging which permits a combination of fast response and high accuracy not available in other industrial speed instruments. The instrument functions can easily be programmed in the field or altered at any time using a unique internal switch design.

Typically, a Tach•Pak 3 tachometer is used with magnetic sensors as a signal source. However, it may receive a sine wave or TTL signal from any frequency source. The resulting speed is used for meter output, analog output or alarms. It is superior in applications requiring fast update times and high accuracy.

It is the customer's responsibility to determine whether the product is proper for customer's use and application.

Features & Advantages

Quicker Response Time - 50 millisecond updates above 100 Hz.

Higher Level of Accuracy - $\pm 0.5\%$ for analog outputs and $\pm 0.05\%$ for relay setpoints in operation over temperature ranges.

Field Programmable - Adaptable to various applications and requirements by utilizing a unique internal switch design. No additional calibration equipment required.

Digital Configuration - Utilizes adaptive period averaging and floating point calculation.

2 Analog Current Outputs - 0-1 milliamps. 0-20 or 4-20 milliamps.

4 Relays - Sealed 6 amp SPDT auto reset or latching.

AC or DC Power - Adaptable to either AC or DC power source.

Applications

- Fast response overspeed shutdown
- PLC or DCS Interface
- Petrochemical production
- Pump or generator alarm
- Low speed tachometer
- Expanding analog scale speed transmitter
- Start-up, over/under speed switching
- Textile production applications
- RPM measurement
- Paper and pulp production
- Turbine speed control input
- Metal production
- Mining applications
- Frequency measurement
- Test labs
- Generator sets
- Food processing
- Conveyor protection
- Printing industry

Ordering P/N	Input Power	Enclosure	Net Weight (lbs.)
T77430-11	120 Vac/24 Vdc	Standard NEMA 1	2.7
-12	240 Vac/24 Vdc	Standard NEMA 1	2.7
-41	120 Vac/24 Vdc	NEMA 4X *	5.9
-42	240 Vac/24 Vdc	NEMA 4X *	5.9
-71	120 Vac/24 Vdc	Explosion Proof **	39.0
-72	240 Vac/24 Vdc	Explosion Proof **	39.0

* See page 16 for dimensions

** See page 17 for dimensions

Specifications

Signal Input

Type: Software selectable for passive or active sensors & terminal block jumper for active sensors.

AC Input (sine wave):

Input Impedance = 2K ohms
 Sensitivity @ 1KHz = 200 mVrms
 Max. Voltage Input = 25 Vrms
 CMRR = > 40 db @ 1KHz, ref. to input threshold.

Pulse Input (TTL compatible):

Input Impedance = 2K ohms
 Min. Pulse Width = 10 μ s
 Logic 0 = V in < .5V
 Logic 1 = V in > 1.5V
 (+ 12 VDC @ 50mA supplied for powered sensors)

Frequency Range: Upper limit 30 KHz, Lower limit software selectable 10 Hz to .0625 Hz.

Power Supply

120 Vac \pm 10%, 50-60 Hz
 24 Vdc (23-30 V), std. 750 ohm analog load or (20-30 V) with 600 ohm analog load.
 15 watts maximum power.

Outputs

Meter Output 0 to 1.0mA \pm .5% of full scale. True current 15 K ohm maximum. Full scale selectable from .1 Hz to 30 KHz.

Analog filter (approx. 2 sec.) switch selectable.

Analog Output: Selectable to 0 to 20 mA or 4 to 20 mA, \pm .5% of full scale. True current 750 ohm maximum.

Full scale and zero scale selectable .1Hz to 30 KHz.

Analog filter (approx. 2 sec.) switch selectable.

Relay Outputs: Four SPDT relays, 6A @ 28Vdc or 240Vac, 170 W or 1800 VA. Selective relay logic: Energize or de-energize above or below setpoint. Auto-reset at setpoint with programmable frequency hysteresis 00.0% to 99.9% or with time delay hysteresis selectable 000 to 999 data acquisitions. Latching relay at setpoint with remote reset.

Response: 50 milisec. updates above 100 Hz. See manual for updates between 20 and 100 Hz, one cycle below 20 Hz.

Accuracy: \pm 0.05% for relay setpoints in operations over temperature range, \pm 0.5% of full scale for meter and analog outputs.

Environmental

Temperature: -10 to 55 $^{\circ}$ C operating.
 -40 to 80 $^{\circ}$ C storage.

Vibration: Designed to meet MIL-810C, Method 514.2, Procedure VIII, Figure 514.2-6. Curve V (1.5 g's 10-200 Hz).

Shock: Designed to meet MIL-810C, Method 516.2, Procedure I, Figure 516.2-2 for ground equipment (30 g's half sine).

Enclosure: Enclosed terminals, same mounting holes as the 300 Tach with enclosure 50% wider. NEMA 4X & explosion proof enclosures optional.

Humidity: 90% relative and non-condensing.

Constant Storage: Retained in EAROM and may be altered 1000 or more times.

Electrical References: Circuit common is isolated from AC power, AC ground and case. DC power, analog output and meter output are referenced to circuit common. Passive inputs are balanced. Active sensor inputs are referenced to circuit common.

Electrical Connections	
TB1 -1 K1 NC -2 K1 COM -3 K1 NO -4 K2 NC -5 K2 COM -6 K2 NO -7 K3 NC -8 K3 COM -9 K3 NO -10 K4 NC -11 K4 COM -12 K4 NO -13 AC Power -14 AC Power -15 Earth	} Relays Shown De-Energized } Contact Rating: 6A Max. at 28Vdc OR 6A Max. at 240Vac
TB2 -1 + 24 Vdc In -2 DC Common -3 Calibrate (when tied to +12V) -4 DC Common -5 + 12Vdc Out (50mA max.) -6 Relay reset (when tied to + 12V) -7 Signal + -8 Signal - -9 Shield -10 Meter + -11 Analog Common -12 Analog +	

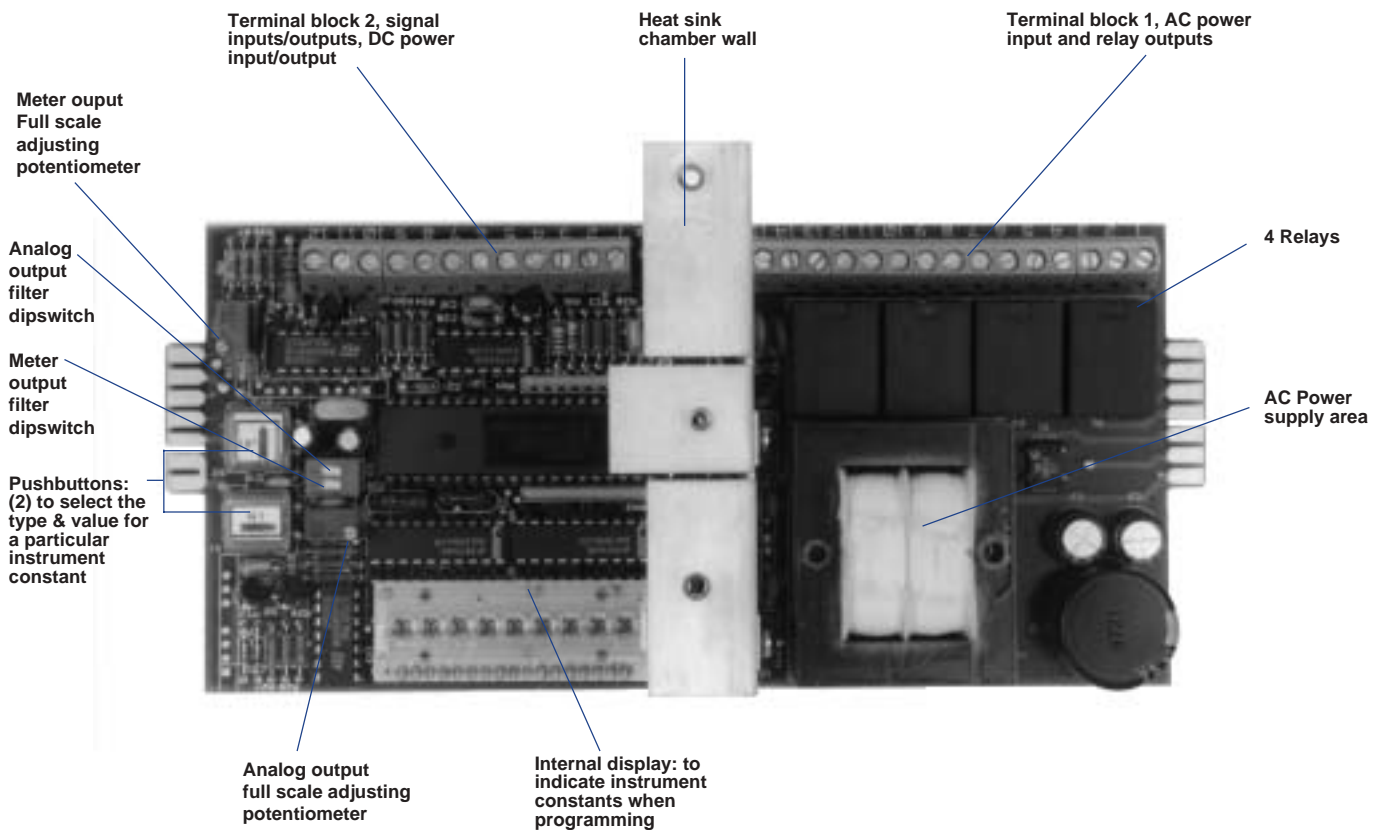
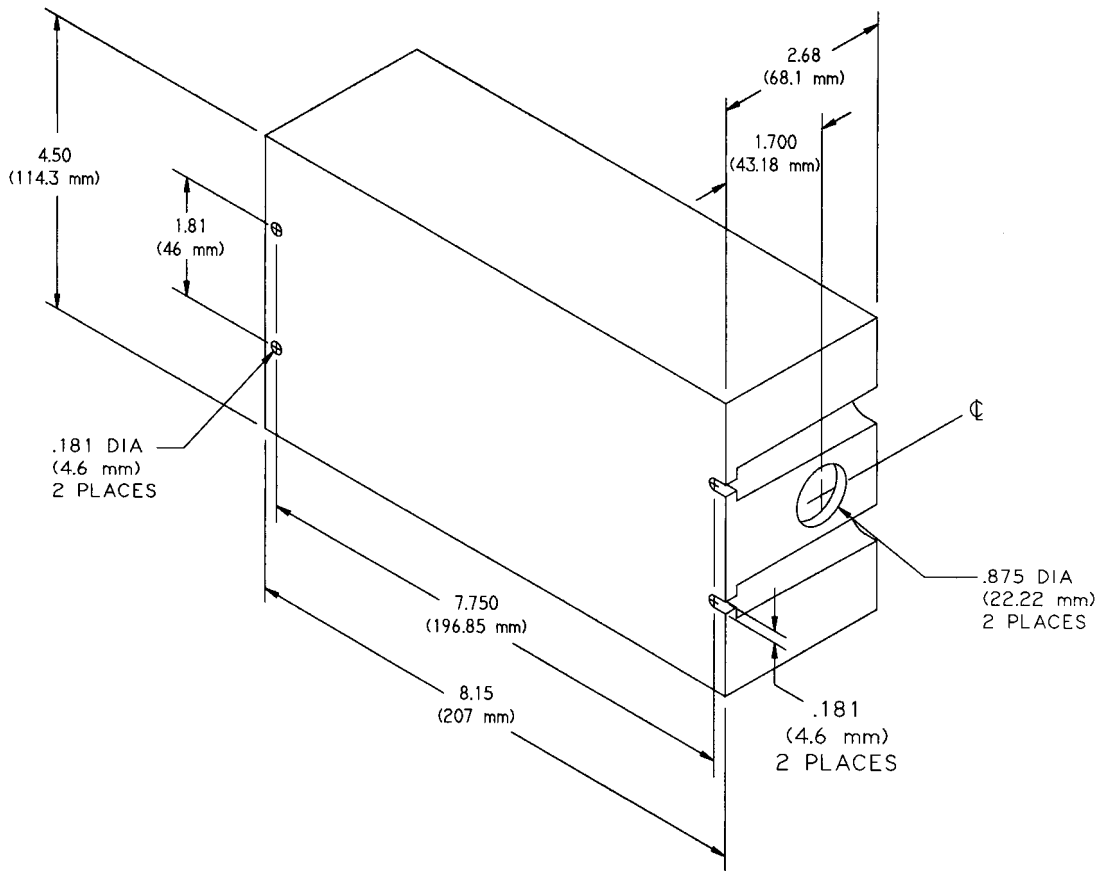

Dimensions in inches and (mm).



TACHTROL® 3 Dual Input Digital Tachometer Part Number Series T77310

The **AI-Tek Tachtrol 3** computing tachometer is a single or dual channel instrument. It measures input frequencies and displays the resulting quantities in RPM, FPM, % Draw or other rates.

Measurement using the period mode (time per event) permits a combination of fast response and high accuracy not available in other industrial speed instruments. A unique method of setting conversion factors and instrument functions permits it to be easily configured or altered anytime during the instrument life.

Features & Advantages

- Single or dual channel
- 9 computed functions
- Measures speed or frequency (2 Hz to 30,000 Hz)
- Adjustable normalization
- Active or passive sensor inputs
- Auto ranging LED display
- AC or DC power
- Panel mount DIN housing

- Function indicators
- 2 relay setpoints
- 4-20 mA, 0-20 mA outputs
- 0-10 Vdc, 0-5 Vdc output
- RS232C serial output
- Expanded and suppressed scale analog outputs
- Optional industrial housings
- Easily re-configured
- ±.05% display and relay accuracy
- 100-200 millise. response
- Field adjustable conversion factors
- MIL 810C vibration and shock
- 0-50°C operating temperature
- Mixed output functions

Applications

A Tachtrol 3 unit is typically used with magnetic sensors as a signal source. However, it may receive a sine wave or TTL signal from any frequency source. The resulting speed or computed function is used for display, alarm or other transmission. It will be superior in applications requiring fast update times and high accuracies. As this instrument

may be re-configured easily, it should be used when scaling factors are subject to change (requirement changes, roll wear, etc.). Certain constant settings produce outputs very useful to very specific applications. *Here are some examples:*

- Fast response overspeed shutdown
- 2 Channel Speed/Draw Monitor
- Bi-directional Tachometer
- Reverse Rotation Alarm
- Low Speed Tachometer
- Clutch Slip Alarm
- Winder Control
- Ahead/Astern Marine Tachometer
- Expanded Analog Scale Speed Transmitter
- Flow Rate Monitor
- Process Time Monitor
- Time per Event Monitor
- Autoranging Tachometer
- Computer Signal Conditioner
- Averaging Tachometer
- Line Frequency Monitor 60.00 Hz/400.0 Hz
- RS232 Speed Transmitter

Ordering P/N	Input Power	Enclosure	Net Weight (lbs.)
T77310 -01	120 Vac/24 Vdc	† Less Encl. } For Explosion Proof	3.3
-02	240 Vac/24 Vdc	† Less Encl. } or NEMA 4X	3.3
-11	120 Vac/24 Vdc	Std. Panel Mount	2.6
-12	240 Vac/24 Vdc	Std. Panel Mount	2.6
-21	120 Vac/24 Vdc	Splashproof Panel Mount	2.7
-22	240 Vac/24 Vdc	Splashproof Panel Mount	2.7
-41	120 Vac/24 Vdc	NEMA 4X *	4.5
-42	240 Vac/24 Vdc	NEMA 4X *	4.5
-71	120 Vac/24 Vdc	Explosion Proof **	39.0
-72	240 Vac/24 Vdc	Explosion Proof **	39.0

† See page 18 for dimensions
 * See page 16 for dimensions
 ** See page 17 for dimensions

It is the customer's responsibility to determine whether the product is proper for customer's use and application.

Operation

The Tachtrol 3 unit may be configured for measurement of a single speed signal, two unrelated speeds or a speed with direction indication (from an AI-Tek bi-directional sensor). In addition, a mathematical function may be computed from two related input signals. These computed functions are:

- Speed A
- Speed B
- A/B (Ratio)
- $\pm A$ (Speed with direction)
- $(A + B)/2$ (Average)
- A-B (Difference)
- B/A (Inverse Ratio)

- $(A-B)/A \times 100$ (% Slip)
- $(B-A)/A \times 100$ (% Elongation)

The Tachtrol 3 unit permits independent assignment of any of these functions to any output (display, analog output and 1 or 2 setpoints). Additionally, the serial digital output may report on any or all outputs continuously or on setpoint alarm. All forms of relay logic are field selectable.

The Tachtrol 3 unit is supplied with an electrically alterable read only memory (EAROM) which

contains all of the constants necessary to define the conversion factors and instrument functions. These constants can be individually displayed and altered by a method similar to the setting of a digital clock.

By utilizing a microcomputer as the heart of the instrument, response time is improved tenfold over the traditional EPUT (events per unit time) tachometry. Further, this fast response time is attained with no sacrifice in digital accuracy.

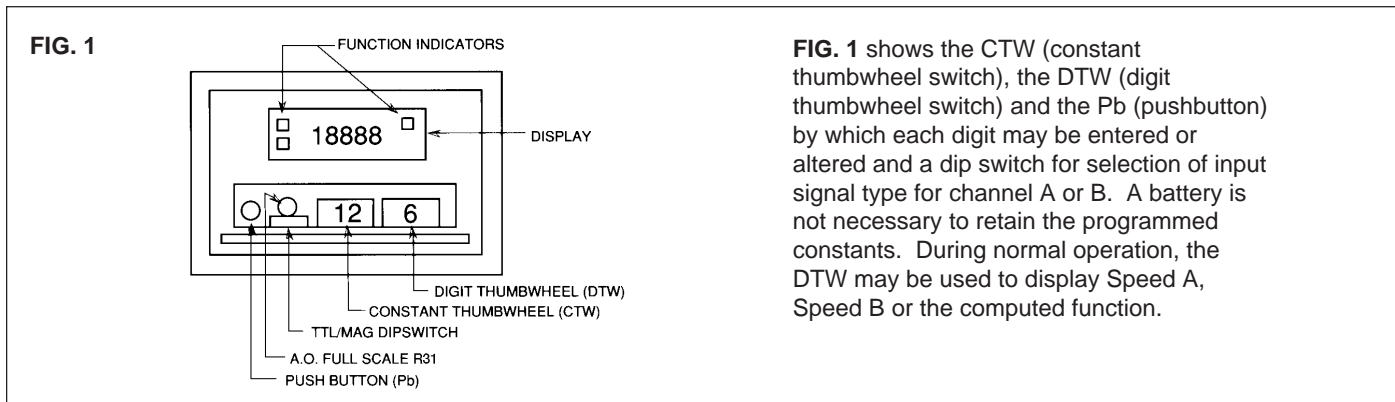

FIG. 1 shows the CTW (constant thumbwheel switch), the DTW (digit thumbwheel switch) and the Pb (pushbutton) by which each digit may be entered or altered and a dip switch for selection of input signal type for channel A or B. A battery is not necessary to retain the programmed constants. During normal operation, the DTW may be used to display Speed A, Speed B or the computed function.

Product Application Guidelines

The part number specifies the hardware. Individual requirements for setpoints, scaling and functions may be set into the instrument during installation. The following is a guide from which data to be entered may be supplied.

Input Frequency

Typically, an input frequency is sensed from rotating gear teeth. Frequency may be obtained from RPM by the formula:

$$f \text{ (in Hz)} = \frac{\text{RPM} \times \text{PPR}}{60}$$

where PPR = pulses per revolution = no. of gear teeth.

The normalization or scaling factor (SF) to be specified may now be obtained for each input by:

$$\text{SF} = \frac{\text{DISPLAY VALUE (RPM, FPM, etc.)}}{\text{INPUT FREQUENCY (Hz)}}$$

The desired form, as an example, is:

- Input A: 2000 Hz = 800 FPM
- Input B: 1600 Hz = 800 FPM

Outputs

The TACHTROL 3 can transmit any of the 6 computed functions, speed A, or speed B, or speed A with direction to any of the 4 outputs. You may specify

one function for each output. Here are the possibilities:

Outputs	Selective Function	Function
Display	-----	Speed A
Analog	-----	Speed B
Relay 1	-----	A - B
Relay 2	-----	$\pm A$ (dir.)
		A/B
		$(A + B)/2$
		$(A - B)/A \times 100$
		$(B - A)/A \times 100$

If one of the outputs is not used, a tenth function, coded O, may be specified, turning the specific output off.

Analog Output

The zero and full scale for the analog output can be programmed to normal or expanded scale, such as:

- 4-20 mA = 0 to 900 FPM or
- 4-20 mA = 450 - 900 FPM

Serial Digital Output

The serial digital (RS232C) output may transmit the value on the display, the analog output value, the two setpoint deviations or all four of these values. They may be continuously transmitted or transmitted on setpoint alarm.

An example of the outputs specified is:
Display: A/B

Analog output: Speed A
RS232C: Transmit all values.
Setpoint 1: A/B

Relays

Each relay may operate on Input A, Input B or the computed function. They may energize, de-energize, latch or auto-reset at the setpoint. Hysteresis (difference between setpoint value and setpoint reset) is normally 5% but may be specified for any value from 1% to 99% of setpoint.

A typical example for a Tachtrol 3 application is:

- Input A: 2000 Hz = 800 FPM
- Input B: 1600 Hz = 800 FPM
- Display: A/B

Analog output: Speed A=0-900 FPM
=4-20mA

Setpoint 1: Energize at 1.00 ratio & above with 1% hysteresis

Setpoint 2: Not used

Serial output: Transmit all values continuously.

This specific example is intended as a guide. The versatility of the Tachtrol 3 unit permits several approaches to configuration. Unavailable information may be omitted as it could be supplied during installation. More detailed information is available in the Tachtrol 3 Instruction Manual.

Specifications

Input Signals

Frequency: 2 Hz to 30K Hz

Passive Sensor (sine wave):

200 mV to 25 Vrms standard 2D ohm impedance, common mode rejection: 40 db, balanced input sensitivity measured at 1K Hz.

Active Sensor (TTL): duty cycle 20 to 80%, DC sensor power is 12 Vdc @ 100 mA [will power two (2) zero velocity sensors or one (1) bi-directional sensor].

Bi-Directional Sensor: One (1) frequency input (TTL input A) and the direction input (TTL Input B) from a bi-directional sensor. [High (+5v) indicates positive direction, and only single speed functions (Speed A) are useful when connected in this operation mode.]

Power Supply

120 Vac±10%, 50-60 Hz
24 Vdc (23-30 V) std. 750 ohm analog load or (20-30 V) with 600 ohm analog load. 15 watts maximum power.

Temperature:

0 to 50°C operating
-40° to 80°C storage

Humidity:

90% relative and non-condensing

Vibration:

Designed to meet MIL 810C, method 514.2. Procedure VIII. Fig. 514.2-6. Curve V (1.5 g's. 10-200 Hz).

Shock:

Disigned to meet MIL 810C, method 516.2. Procedure I Fig. 516.2-2 for ground equipment (30 g's. half sine).

Displays:

4 1/2 digit with minus sign & decimals (positive direction indicated by no minus sign).

Bright .56" Red LED

Fixed or floating decimal (3 places)

Number range ±0.000 to ±19999

Three (3) LED function indicator lamps.

Outputs

Analog: 0-20 mA or 4-20 mA, field selectable, output consists of one thousand 20 µA steps. 750 ohm load maximum. Span pot-adjustable ±10%. Zero and full scale set into memory in engineering units.

0-10 Vdc or 0-5 Vdc output obtained by selecting the 0-20mA mode and using a resistor across the input of the receiving instrument whose parallel combination with the input resistance of the receiver is 500 ohms or 250 ohms respectively.

Serial Digital: RS232C compatible transmit only ASCII. 300 baud. asynchronous with odd parity. 2 stop bits and carriage return. Transmission format selectable to transmit continuously or on any setpoint alarm. Transmission preceded by linefeed (Lf) and followed by carriage return (Cr). Each value consists of a space (Ø), a two (2) digit identifier, a colon and a right justified (7) character field of data (4 1/2 digit number, sign and decimal) Plus (+) sign, and leading zeros indicated by spaces (bbb). The following are examples of the four (4) type transmissions:
LfbDO: (display value) Cr
LfbAO: (analog output value) Cr
LfbS1: (SP 1 value) bS2 (SP 2 value) CR (SP value = difference between setpoint and actual)

LfbDO: -19.999bAC: b199.99bSP1: bbb-999bSP2:bbb0.00Cr

Relay Setpoints: 2 relays standard, SPDT, 6A @ 28 Vdc or 240 Vac, 170W or 1800 VA. Selective relay logic: Energize or de-energize above or below setpoint, auto-reset with hysteresis selectable 0-99% in 1% steps, latching (reset by pushbutton located behind front panel door).

Accuracy: (including temp. variations)
Digital ±.03% typical (±.05% max.) & ± 1 least significant digit
Analog ±.3% of range

Response Times:

Display updated approx. every 1/2 sec. based on latest available input measurement(s).

Serial Output: Transmits each output value in approx. 1/2 second based on input measurements obtained at the time each value is transmitted.

Analog & Relay Outputs updated at a variable rate depending on the frequency. the typical & maximum response times are:

Above 100 Hz = 100 ms typical
200 ms max.
2 to 100 Hz = 2 cycles + 30 ms typ.
6 cycles + 30 ms max.

Below 2 Hz = Measurement considered 0
For values computed from both signal inputs a new computed value is updated each time either signal completes a measurement.

Range of Normalization (linear or inverse only)

Input frequencies A & B may be normalized by a number from .5000 x 10⁻⁷ to 2.000 x 10⁷

Normalization is entered in the form:
+1XXXXX
-1XXXXX

Additional display normalization range ±.001 to 19999.

Constant Storage:

Retained in EAROM and may be altered 1000 or more times.

Electrical References:

Circuit Common is isolated from AC power, analog and case.
DC power analog output and serial output are referenced to circuit common. Passive inputs are balanced. Active sensor inputs are referenced to circuit common.

Electrical Connections

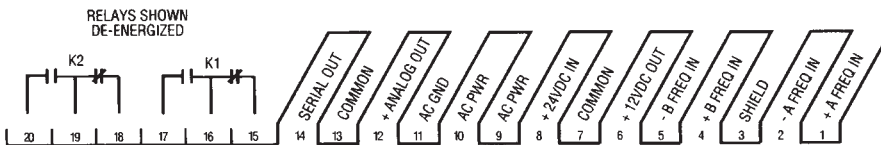

Panel Mounting Dimensions

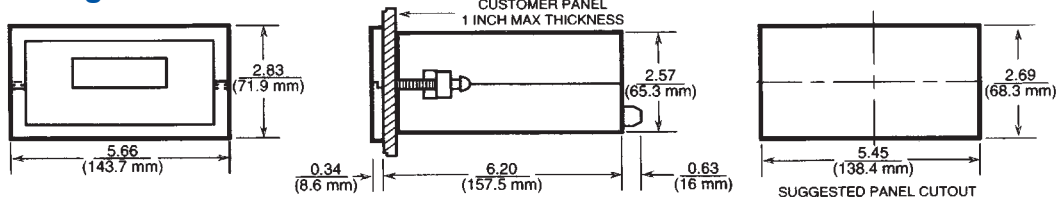

Dimensions in inches and (mm)

Enclosure Options

The following NEMA rated and hazardous location enclosures are available for certain AI-Tek Instruments tachometer products found in this catalog. When ordering an instrument and enclosure, the instrument will be mounted within the enclosure ready for your application.

The dimensions below will aid you in determining the mounting configuration for each enclosure. Contact your sales representative or factory to answer questions on your specific applications.

NEMA 4X

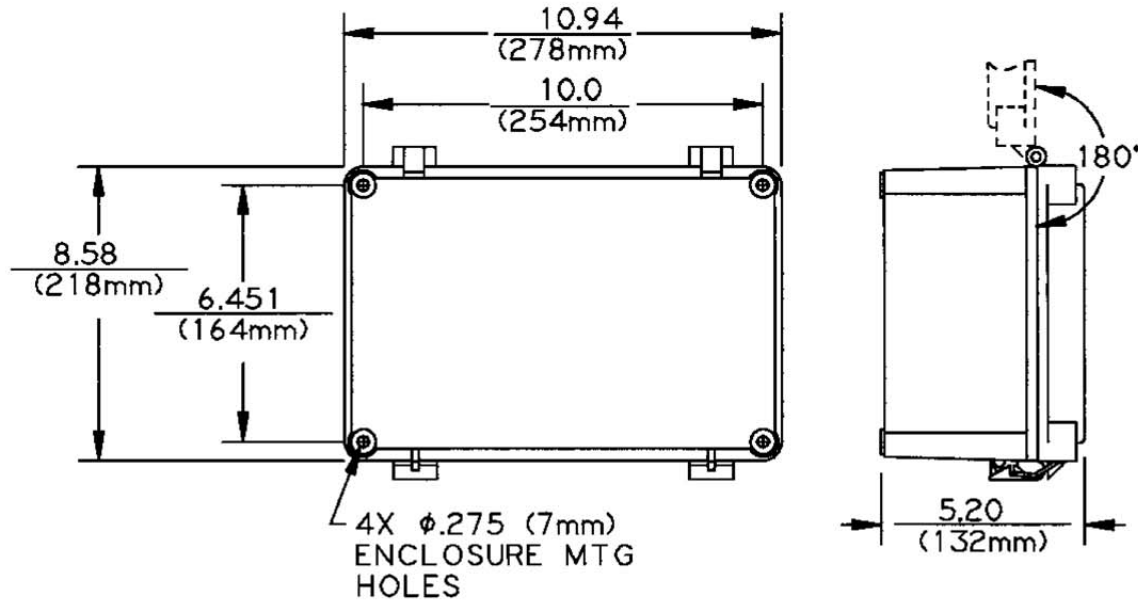

Tachtrol 3



NEMA 4X

Meets the requirements of NEMA 3, 12, 4 and 4X. Tachtrol 3 illustrated above.

Dimensions in inches and (mm).

X STYLE

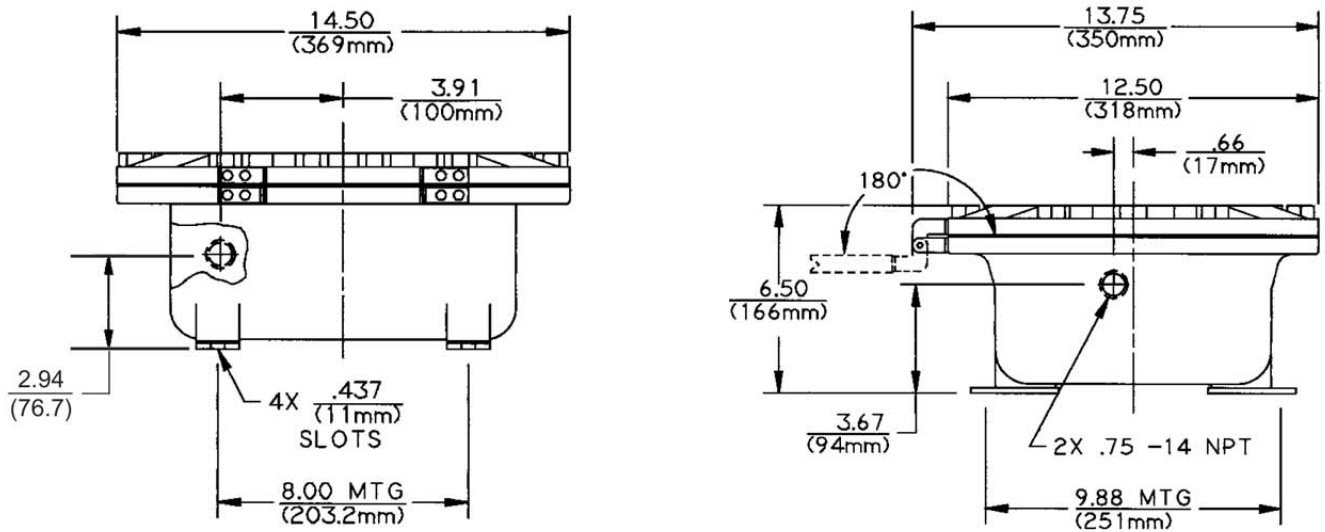

X STYLE

Meets the explosion-proof requirements of hazardous locations, Class 1, Division 1, Groups B,C & D; Class II, Division 1, Groups E,F & G. Also meets NEMA 3, 4, 7 & 9.

Dimensions in inches and (mm).

Tachtrol 3 Less Enclosure

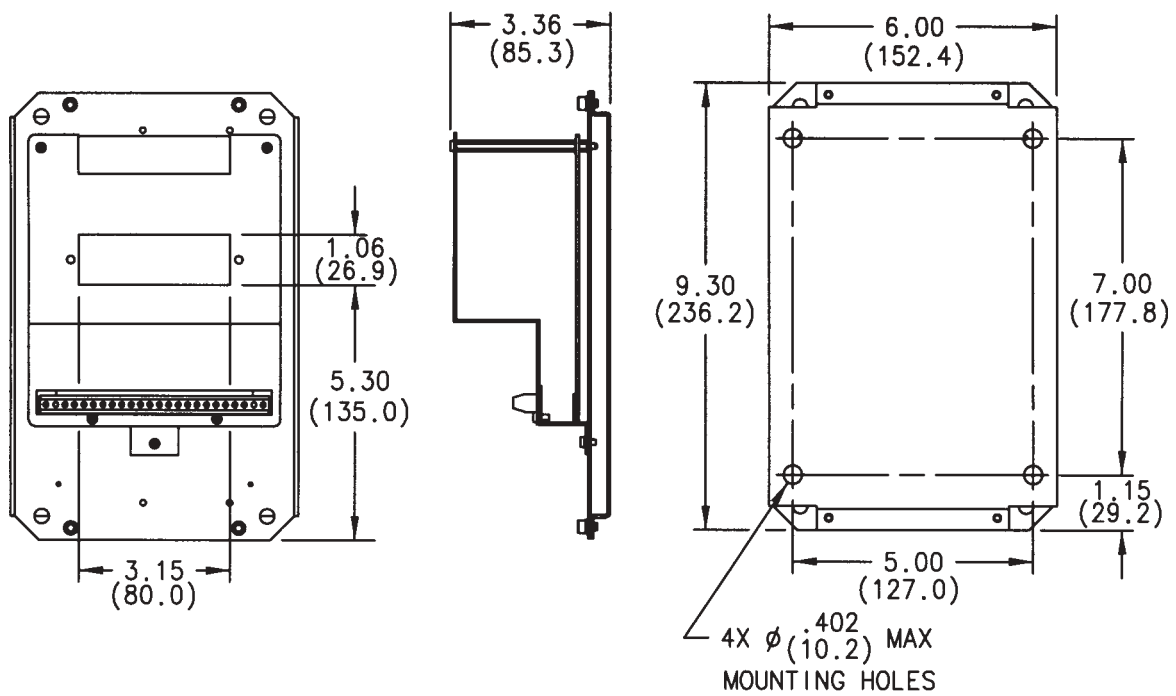

T77310-01 & -02



Speed Sensors

AI-Tek Instruments manufactures hundreds of different designs of speed sensors. This catalog lists the standard units we developed, based on years of design experience and knowledge, to provide you readily available products to solve your sensor solution to your speed control or indication needs. Many of the hundreds of AI-Tek speed sensors we produce are designed for special applications which allows us to offer a highly versatile and flexible product line.

Designed to meet severe industrial, automotive and aerospace environments, AI-Tek speed sensors, will provide reliable, around-the-clock operation for many years under adverse conditions. Our design engineers have paid particular attention to trouble areas such as vibration, shock, extreme temperatures, wet, oily and corrosive atmospheres. Many of our speed sensors are specifically designed for high temperature, high or low speeds, various targets or for precise accuracy and timing applications. AI-Tek uses primarily the three technologies of variable reluctance, magneto-resistive and Hall effect to convert motion into an electronic signal. By selecting the best technology for a specific application we can assure years of reliable performance.

This catalog offers a variety of options readily available through our distributors. If you cannot find a catalog item to meet your specific requirements, please contact your area distributor with your specifics; there is probably an existing design which comes close to your requirements. As a world leader in producing quality speed sensors, AI-Tek Instruments will provide a superb price/performance ratio.

Passive Magnetic Sensors

Control and protection circuits have relied on variable reluctance technology for years. With few components and no moving parts, the passive magnetic speed sensors can provide a signal from the inside of an aircraft engine at temperatures approaching 425°C or from the hub of an automobile wheel at high shock and vibration. The advantages of these sensors are:

- High reliability
- Simple installation
- Long life due to no moving parts or contacts
- Self powered operation
- Wide variety of shapes and sizes
- Easy alignment
- Can be designed for almost any environment

Due to their flexibility, you will find AI-Tek variable reluctance sensors in everything from low-cost consumer products to highly-accurate automotive engine ignition systems to flight-worthy aircraft engine controls.

It is the customer's responsibility to determine whether the product is proper for customer's use and application.

Principles of Operation

The internal construction of the typical AI-Tek variable reluctance sensor is a magnet, pole piece and coil (See figure 1). A magnetic field (lines of flux) extends from the magnet, through the pole piece and coil out into the air space at the end of the sensor. The return path of the magnetic field is from the air space to the other end of the magnet. As a ferrous object approaches the tip of the pole piece, the magnetic field increases and then decreases as the object moves away from the pole piece. The snap or the rapid change in the magnetic field induces an AC voltage signal in the coil. With an ideal target and matching sensor, the induced voltage is in the shape of a sine wave.

As can be seen, the generated frequency signal is directly proportional to the number of ferrous objects passing the pole piece per unit time. The amplitude of the voltage output is proportional to the speed of the ferrous objects passing the pole piece.

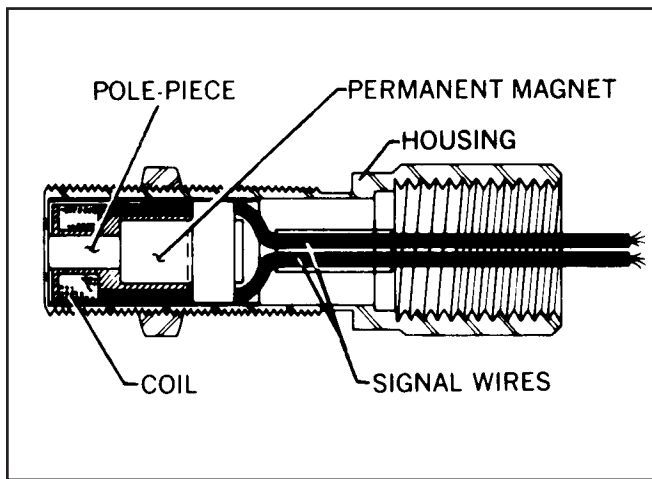

Figure 1 - Internal configuration of typical sensors.

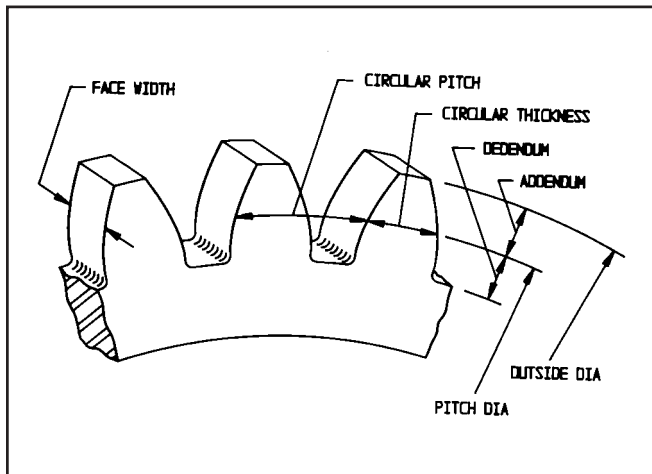

Figure 2 - Common terms used in defining gears.

Many applications of AI-Tek magnetic sensors use gears as targets. Typical sensor output wave forms with various targets are illustrated in Figure 3. Testing sensors with gears rather than other ferrous discontinuities such as sprockets, keyways, boltheads, etc. is because the output is predictable and repeatable. See Figure 2 for commonly used gear terminology.

$$\text{Diametral Pitch} = \frac{\text{No. of Teeth} + 2}{\text{Outside Dia. of Gear (in.)}}$$

The performance of a sensor can be easily defined when using a gear for a target; it also allows for estimated performance with alternate targets. AI-Tek sensors are tested with AGMA standard gears; the performance curves are included in this catalog.

AI-Tek Instruments differs from most sensor manufacturers in the presentation of performance curves and test parameters. Most existing data is specified at a surface speed of 1000 in/sec and 0.005 in. air gap; we feel that a 0.030 in. air gap and 500 in/sec. surface speed (1800 RPM motor with 5 to 6 in. dia. gear) are more realistic parameters to specify performance.

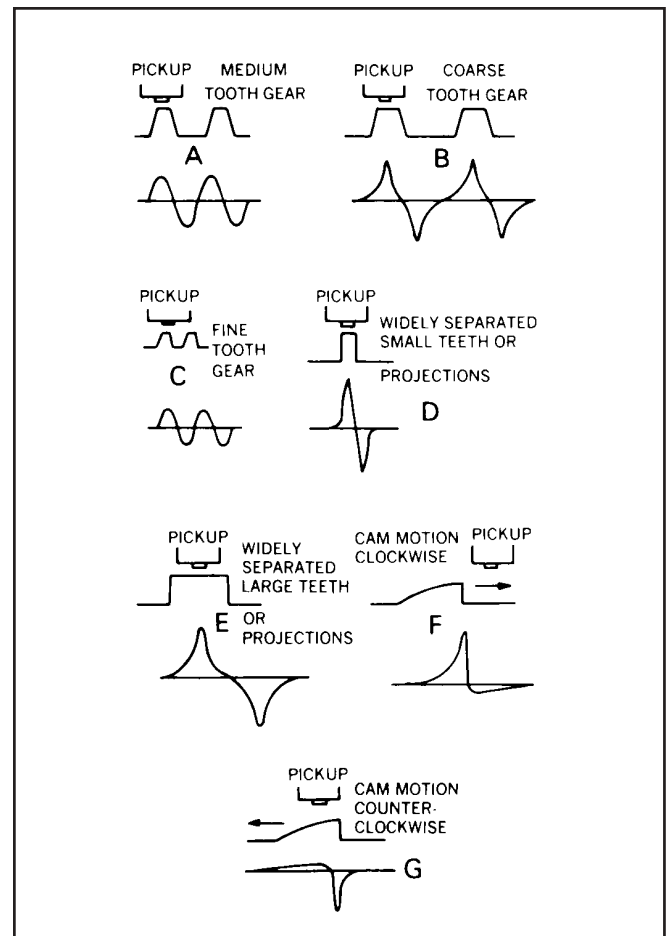

Figure 3 - Generated voltage waveforms.

Magnetic Sensor Selection

The following information is supplied for assistance in selecting the proper sensors for your particular applications. One of the fundamental questions to be answered is, "Will there be enough sensor output voltage at the lowest operating speed?"

The sensor output voltage depends on:

- *Surface Speed* - speed target passes pole piece
- *Gap* - distance between target and pole piece
- *Target Size* - geometric relationship of pole piece and target
- *Load Impedance* - connected to sensor

The surface speed of a gear depends upon its diameter and RPM. Surface speed is expressed in terms of inches per second (IPS).

$$\text{Surface Speed (IPS)} = \frac{\text{RPM} \times \text{Outside Dia. (in.)} \times \pi}{60}$$

There is an optimum pitch (or tooth size) to obtain the highest possible output from a sensor, but this is seldom necessary. Figure 4 illustrates the relationship of tooth size and spacing for optimum magnetic sensor output. Using a fine tooth gear, relative to a large pole piece diameter sensor, results in a lower generated voltage because the flux also passes into adjacent teeth, resulting in a lower total flux variation.

The relationship between pole piece diameter and gear pitch and its effect on the output of a sensor is described in Table A.

The load impedance, with relation to the internal impedance of the sensor, dictates the amount of sensor output voltage that will be seen by that load.

Magnetic sensors are designed with the lowest practical impedance consistent with providing maximum output. The load impedance should be high in relation to the impedance of the sensor to minimize the voltage drop across the coil and to deliver the maximum output to the load.

Most of the output voltages listed in this catalog are based on a load impedance of 100k ohms. To use a generality, the load impedance should be 10 times that of the sensor.

In order to assist you in selecting your sensor, AI-Tek Instruments has developed an output vs. speed curve for each sensor family. By looking at the application extremes of highest speed/lowest gap and lowest speed/highest gap, the full variation of sensor output can easily be determined. We also specify each family in two ways **Standard** - minimum output voltage at 1000 IPS, 0.005 in. gap. **Guarantee Point** - minimum output voltage at 500 IPS, 0.030 in. gap. Sensors with .187" dia. pole piece are tested with an 8 D.P. gear, 100k ohms load; .106" dia. & smaller pole piece sensors are tested with a 20 D.P. gear, 100k ohms load.

Table A: Relative Output Vs. Gear Pitch

Pole Piece Dia. (in)	Gear Pitch						
	8	12	16	20	24	32	48
.187	1.00	0.83	0.33	0.16	—	—	—
.106	1.41	1.41	1.27	1.00	0.70	0.28	0.07
.093	1.25	1.25	1.25	1.00	0.75	0.37	0.12
.062	0.95	1.07	1.00	1.00	0.92	0.90	0.36
.040	1.00	1.00	1.00	1.00	1.00	0.90	0.60

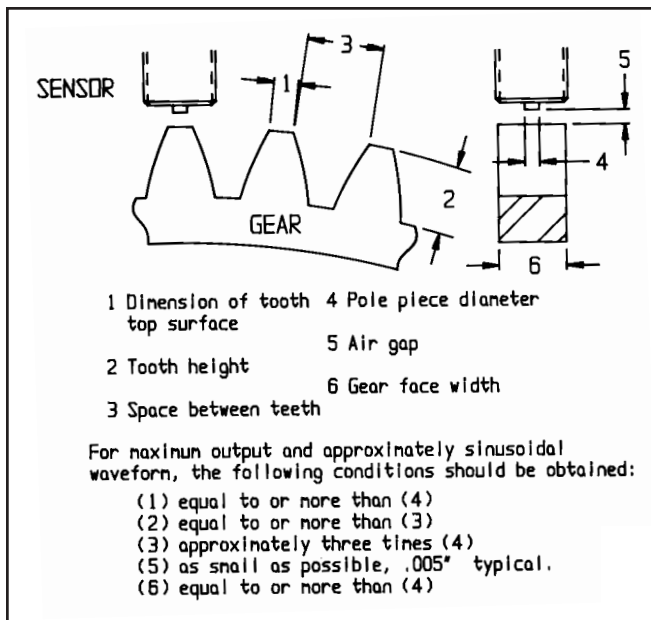

Figure 4: Sensor output as a function of gear tooth size.

Calculation of Output Voltage

Selection of the proper AI-Tek magnetic sensor may require the calculation of sensor output voltage to assure proper operation in your specific application. To assist in this area, let us consider the following typical application: Requirement is speed display with overspeed and underspeed control as well as 4-20 mA signal to a PLC. Speed range is 0-3600 RPM with low speed set point at 300 RPM, available shaft diameter for mounting a gear is 2.000 in. and a .030 in. air gap is ideal.

You have selected a Tachtrol 3, P/N T77310-11, with a 60T steel, split gear, P/N G79870-202-1901, and you are considering to use sensor P/N 70085-1010-001. The question is if the sensor has enough output voltage at 300 RPM.

We can list the following parameters:

- a. Tachtrol 3: Load impedance - 2000 ohms
Sensitivity - 200 mV rms
- b. Split gear: Outside dia. - 5.166 in.
D.P. - 12
No. of Teeth - 60
- c. Sensor: Standard output voltage - 40V (P-P) min.
Guarantee Point - 3.4V P-P min.
D.C. Resistance - 130 ohms max.
Typical inductance - 33 mH ref.

Step 1: Calculate surface speed of gear:

$$SS = \frac{RPM \times \text{Outside Dia.} \times \pi}{60} = \frac{300 \times 5.166 \times 3.14}{60}$$

$$SS = 81 \text{ IPS}$$

Step 2.: Determine Peak-to-Peak output voltage:

Referring to the performance curves of sensor P/N 70085-1010-001 the min. output voltage is approx. 0.3 V (P-P) at 81 IPS and 0.030 in. gap. It is a fact that output voltage vs. surface speed is a near linear function; therefore, another method of determining output voltage is to set up a ratio using the guarantee point:

$$\frac{3.4V \text{ (P-P)}}{500 \text{ IPS}} = \frac{E}{81} \quad E = .55V \text{ (P-P)}$$

Step 3: Correction for pitch:

For a 0.106 in. pole piece dia. and a 12 D.P. gear the correction factor from Table A is 1.41. (See pg. 25.)

$$E_c = .55 \times 1.41 = .78 \text{ V (P-P)}$$

Step 4: Converting to rms voltage:

Simply divide by 3, a method which is close enough. (If the peak-to-peak output voltage is a sine function, the divisor is 2 times the square root of 2 or 2.83).

$$E_c = .78 \div 3 = .26 \text{ V rms}$$

Step 5: Correction for load:

The .26V or 260 mV rms sensor output voltage will be divided across the impedance of the load and sensor. The load impedance is 2000 ohms resistive. The impedance of the sensor has a resistive and inductive element. At low frequencies the inductive element is very small and can therefore be disregarded, leaving the max. DC resistance of 130 ohms for consideration.

The load correction factor (f_L) can be expressed as:

$$f_L = \frac{Z \text{ (load)}}{Z \text{ (load)} + Z \text{ (sensor)}} = \frac{2000}{2130} = .94$$

$$E_c = .94 \times 260 = 244 \text{ mV rms}$$

The final adjusted value is 244 mV rms.

As stated earlier, the sensitivity or threshold of the Tachtrol•3 is 200 mV rms at the stated conditions, the selection of P/N 70085-1010-001 is acceptable.

If the final value of E_c had been slightly less than 200 mV, a reduction of the air gap (from .030" to .025") would boost the output above 200 mV.

If it should be determined that the required sensor cannot be selected from the catalog models, the best procedure is to compile a list of all your requirements and contact your area distributor to assist you in the selection of the correct sensor.

Passive Speed Sensors

5/8 – 18 FAMILY

General Purpose

Ordering Part #	Thread Length (A)
70085-1010-001	1.125 (28.57)
70085-1010-003	2.625 (66.67)
70085-1010-018	3.625 (92.07)
70085-1010-118	5.000 (127.00)

(Select cable from group "A", see index)

Performance Curves

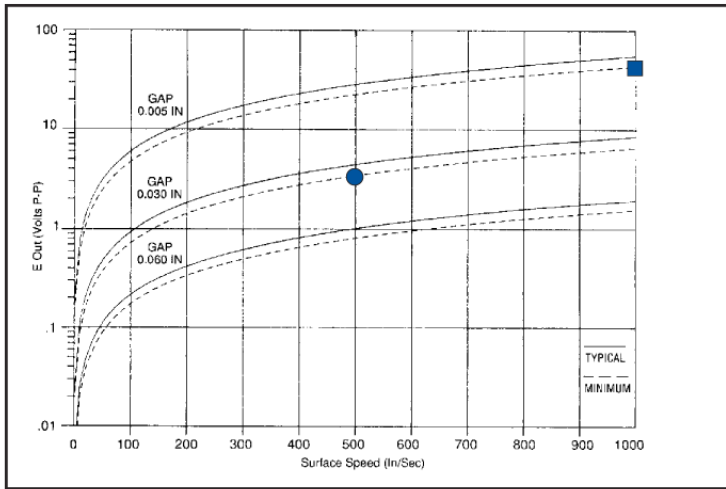

Based on 20 D.P. Gear

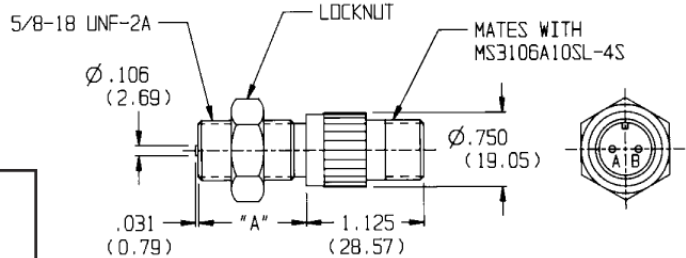

Specifications:

- Output Voltage (Standard): 40 V (P-P)
 - Output Voltage (Guarantee Point): 3.4 V (P-P)
- DC Resistance: 130 ohms max.
 Typical Inductance: 33 mH ref.
 Output Polarity: Pin 'B' positive
 Operating Temperature: -55 to +107°C
 Net Weight: 5 oz. max.

High Sensitivity

Ordering Part #	Thread Length (A)
70085-1010-002	1.125 (28.57)
70085-1010-175	2.625 (66.67)
70085-1010-026	3.625 (92.07)
70085-1010-408	5.000 (127.00)

(Select cable from group "A", see index)

Performance Curves

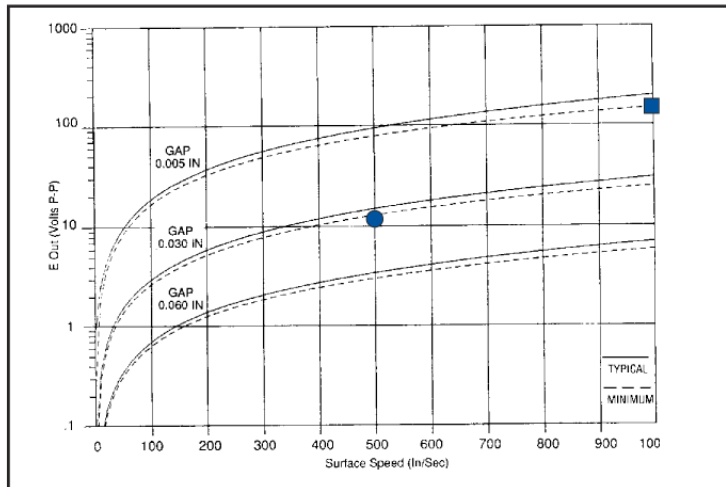

Based on 20 D.P. Gear

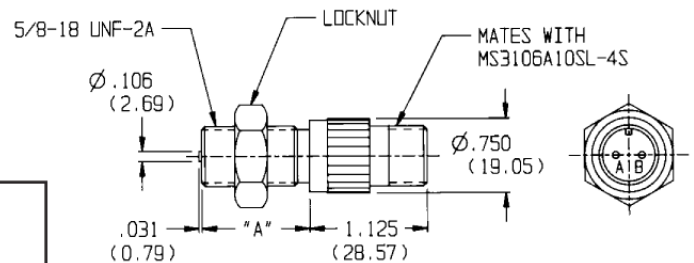

Specifications:

- Output Voltage (Standard): 150 V (P-P)
 - Output Voltage (Guarantee Point): 12.9 V (P-P)
- DC Resistance: 1500 ohms max.
 Typical Inductance: 360 mH ref.
 Output Polarity: Pin 'B' positive
 Operating Temperature: -55 to +107°C
 Net Weight: 5 oz. max.

Passive Speed Sensors

5/8 – 18 FAMILY

Power Output

Ordering Part # **Thread Length (A)**
 70085-1010-028 1.437 (36.50)
 (Select cable from group "A", see index)

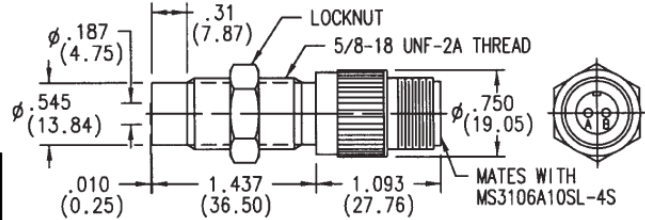

Performance Curves

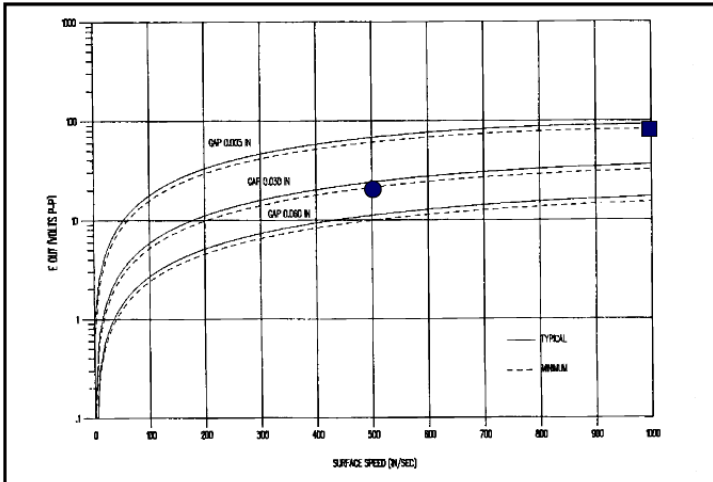

Based on 8 D.P. Gear

Specifications:

- Output Voltage (Standard): 75 V (P-P)
- Output Voltage (Guarantee Point): 21.5 V (P-P)
- DC Resistance: 210 ohms max.
- Typical Inductance: 50 to 95 mH ref.
- Output Polarity: Pin "B" positive
- Operating Temperature: -73 to +107° C
- Net Weight: 2.2 oz. max.

Conduit Fitting – General Purpose

Ordering Part # **Thread Length (A)**
 70085-1010-004 1.125 (28.57)
 70085-1010-469 2.750 (69.85)

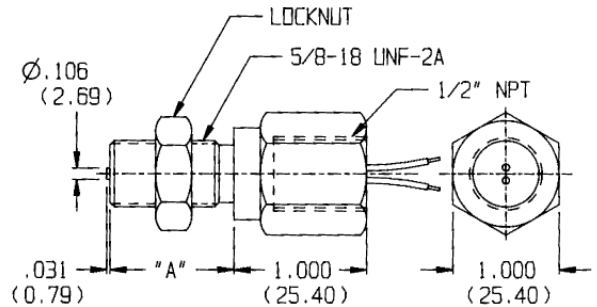

Performance Curves

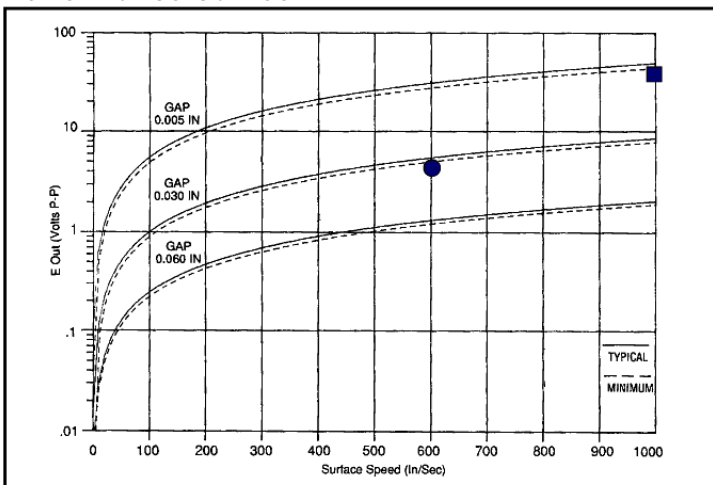

Based on 20 D.P. Gear

Specifications:

- Output Voltage (Standard): 43 V (P-P)
- Output Voltage (Guarantee Point): 4.3 V (P-P)
- DC Resistance: 130 ohms max.
- Typical Inductance: 32-46 mH ref.
- Output Polarity: Red lead positive
- Operating Temperature: -73 to +107° C
- Lead length: 10 ft (3.05 m)
- Net Weight: 16 oz. max.

Al-Tek Instruments, Cheshire, CT USA

Dimensions in inches and (mm).

Passive Speed Sensors

5/8 – 18 FAMILY

Full Thread – Power Output

Ordering Part #	Thread Length (A)
70085-1010-131	1.750 (44.45)
70085-1010-214	3.000 (76.20)

Performance Curves

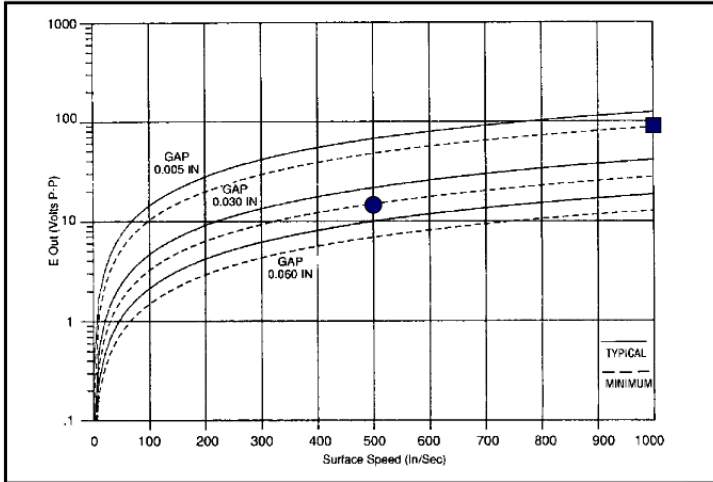

Based on 8 D.P. Gear

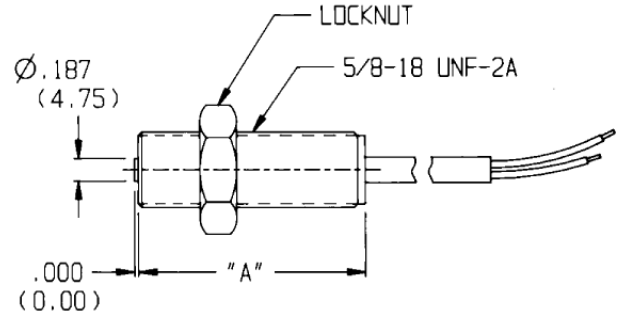

Specifications:

- Output Voltage (Standard): 120 V (P-P)
- Output Voltage (Guarantee Point): 15.1 V (P-P)
- DC Resistance: 220 ohms max.
- Typical Inductance: 40-60 mH ref.
- Output Polarity: White lead positive
- Operating Temperature: -55 to +107° C
- Cable Length: 10 ft (3.05 m)
- Net Weight: 5 oz. max.

Full Thread – General Purpose

Ordering Part #	Thread Length (A)
70085-1010-078	1.875 (47.62)
70085-1010-137	3.000 (76.20)

Performance Curves

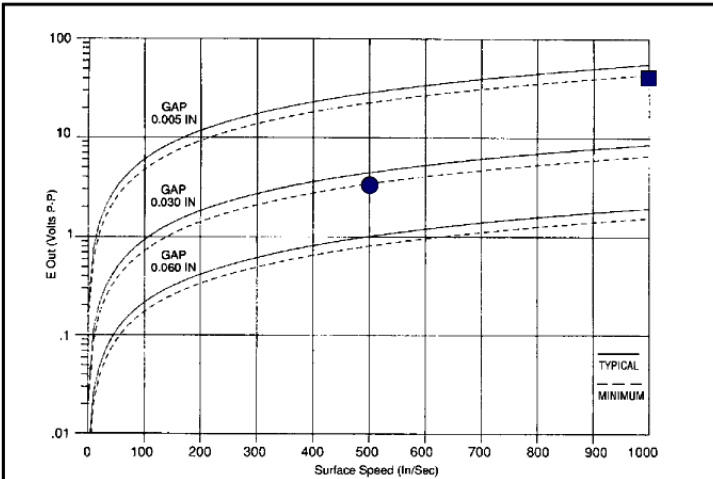

Based on 20 D.P. Gear

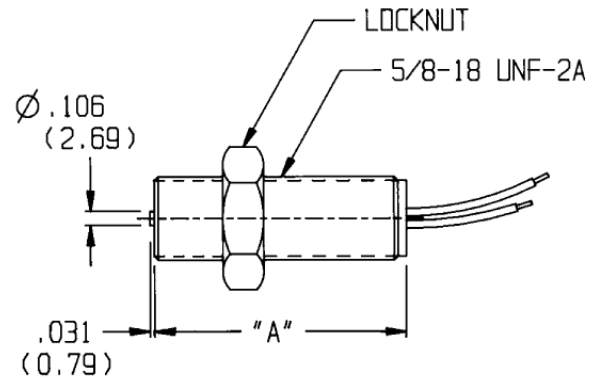

Specifications:

- Output Voltage (Standard): 40 V (P-P)
- Output Voltage (Guarantee Point): 3.4 V (P-P)
- DC Resistance: 130 ohms max.
- Typical Inductance: 33 mH ref.
- Output Polarity: white lead positive
- Operating Temperature: -55 to +107°C
- Lead Length: -078, 12 in (30.5 cm)
- 137, 24 in (60.9 cm)
- Net Weight: 3 oz. max.

AI-Tek Instruments, Cheshire, CT USA

Passive Speed Sensors

5/8 – 18 FAMILY

Full Thread – High Sensitivity

Ordering Part #	Thread Length (A)
70085-8080-003	1.812 (46.03)
70085-1010-220	3.000 (76.20)

Performance Curves

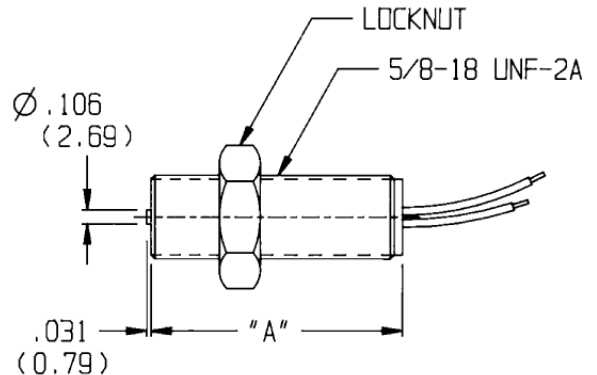
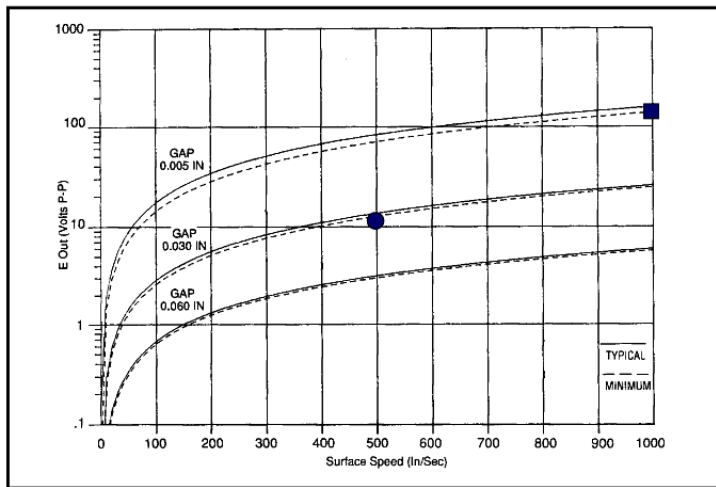

Specifications:

- Output Voltage (Standard): 150 V (P-P)
- Output Voltage (Guarantee Point): 12.8 V (P-P)
- DC Resistance: 1650 ohms max.
- Typical Inductance: 500 mH ref.
- Output Polarity: White lead positive
- Operating Temperature: -55 to +107°C
- Lead Length: -003, 12 in (30.5 cm)
-220, 36 in (91.4 cm)
- Net Weight: 3 oz. max.

Molded – High Sensitivity

Ordering Part #	Thread Length (A)
70084-1713-111	1.125 (28.57)

(Select cable from group "A", see index)

Performance Curves

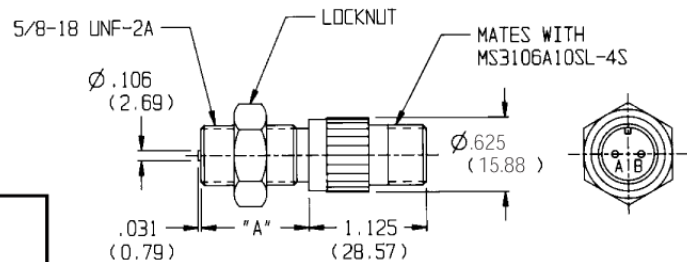
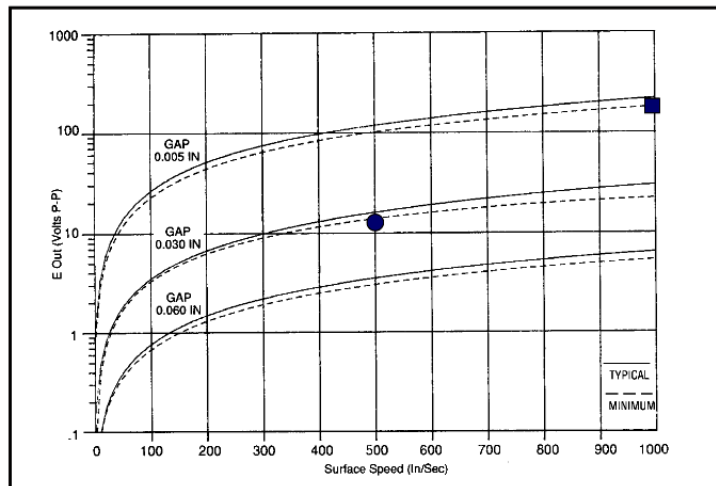

Specifications:

- Output Voltage (Standard): 190 V (P-P)
- Output Voltage (Guarantee Point): 13.9 V (P-P)
- DC Resistance: 1200 ohms max.
- Typical Inductance: 400 mH ref.
- Output Polarity: Pin 'B' positive
- Operating Temperature: -40 to +150°C
- Net Weight: 2 oz. max.

Al-Tek Instruments, Cheshire, CT USA

Dimensions in inches and (mm).

Passive Speed Sensors

5/8 – 18 FAMILY

Molded

Ordering Part #	Thread Length (A)
70085-1010-421	2.475 (62.87)
70085-1010-425	3.000 (76.20) * M16 x 1.5 Thd.
70085-1010-424	4.493 (114.12)

(Select cable from group "A", see index)

Performance Curves **

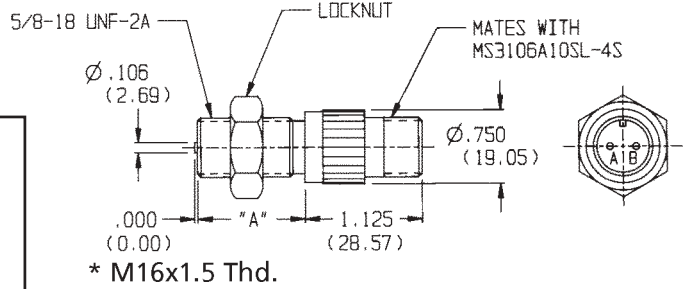
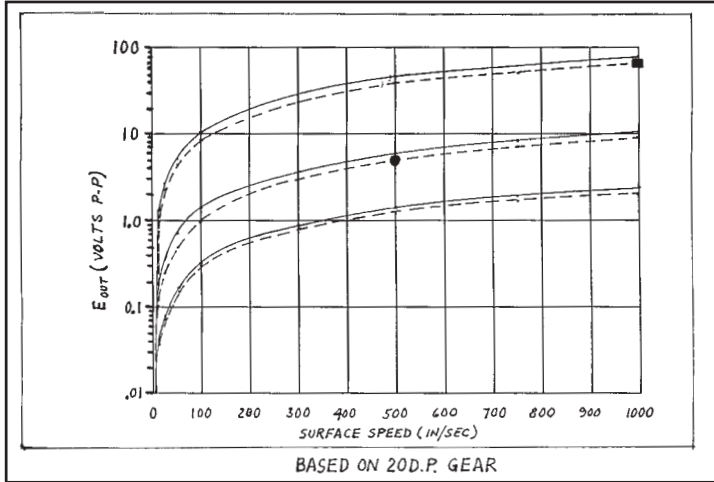

Specifications:

- Output Voltage (Standard): 63 V (P-P)
- Output Voltage (Guarantee Point): 4.9V (P-P)
- DC Resistance: 250 ohms max.
- Typical Inductance: 63 mH ref.
- Output Polarity: Pin 'B' positive
- Operating Temperature: -55 to +107° C
- Net Weight: 5 oz. max.

Passive Speed Sensors

3/8 – 24 FAMILY

General Purpose

Ordering Part #	Thread Length (A)
70085-1010-007	.812 (20.62)
70085-1010-056	3.500 (88.90)

Performance Curves

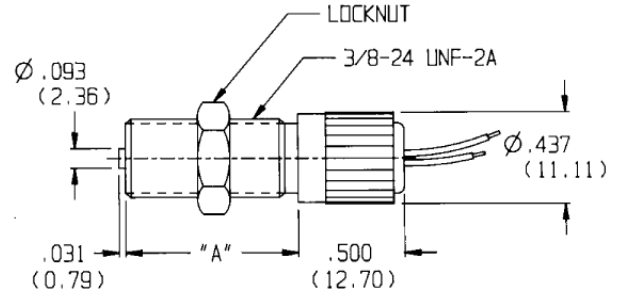
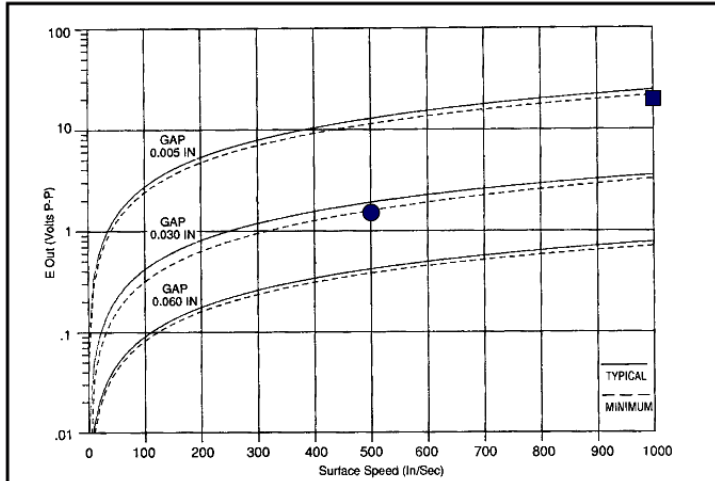

Specifications:

- Output Voltage (Standard): 21 V (P-P)
- Output Voltage (Guarantee Point): 1.6 V (P-P)
- DC Resistance: 115 ohms max.
- Typical Inductance: 22 mH ref.
- Output Polarity: White lead positive
- Operating Temperature: -55 to +107°C
- Lead Length: 6 in (15.2 cm)
- Net Weight: 2 oz. max.

High Sensitivity

Ordering Part #	Thread Length (A)
70085-1010-086	.812 (20.62)
70085-1010-355	.812 (20.62)

Performance Curves

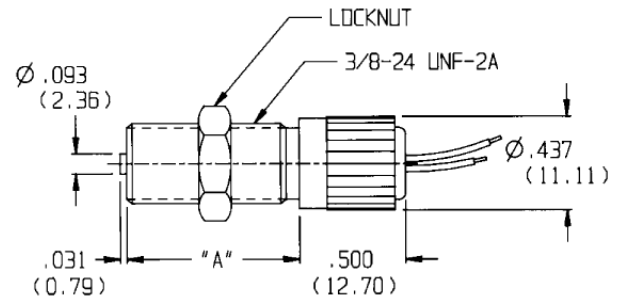
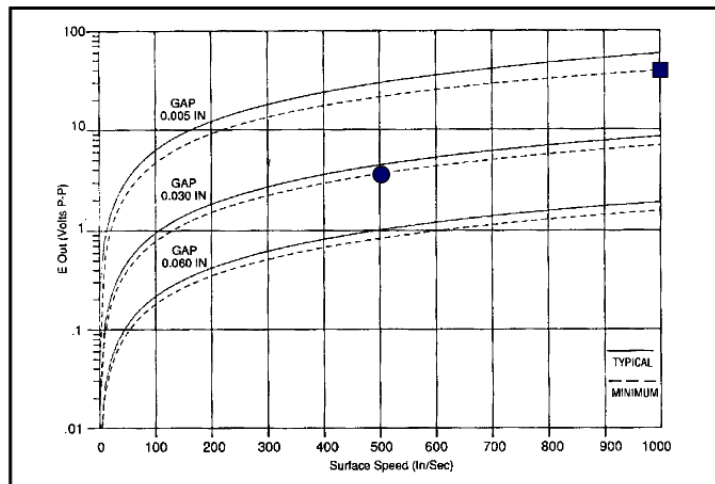

Specifications:

- Output Voltage (Standard): 55 V (P-P)
- Output Voltage (Guarantee Point): 3.6V (P-P)
- DC Resistance: 700 ohms max.
- Typical Inductance: 125 mH ref.
- Output Polarity: White lead positive
- Operating Temperature: -55 to +107°C
- Lead Length: -086, 18 in (45.7 cm)
- Cable Length: -355, 40 in (101.6 cm)
- Net Weight: 2 oz. max.

Al-Tek Instruments, Cheshire, CT USA

Dimensions in inches and (mm).

Passive Speed Sensors

3/8 – 24 FAMILY

General Purpose – High Temperature

Ordering Part #	Thread Length (A)	
70085-1010-041	.812	(20.62)
70085-1010-428	1.500	(38.10)
70085-1010-458	3.500	(88.90)

Performance Curves

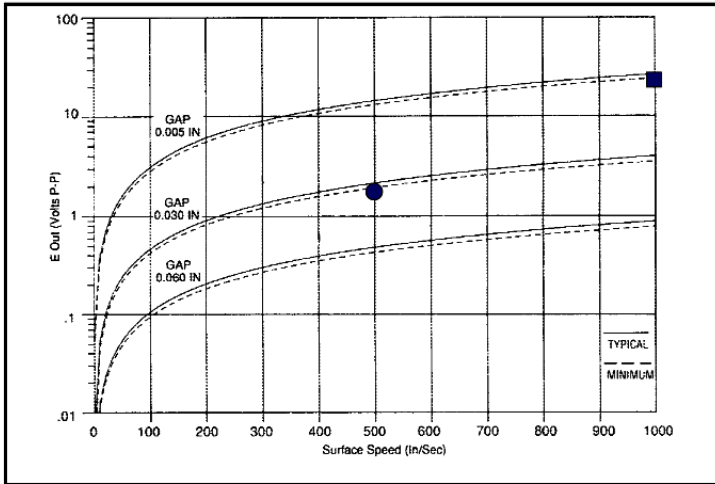

Based on 20 D.P. Gear

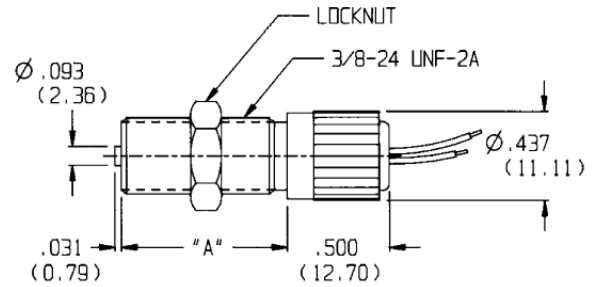

Specifications:

- Output Voltage (Standard): 24 V (P-P)
- Output Voltage (Guarantee Point): 2.0 V (P-P)
- DC Resistance: 110 ohms max.
- Typical Inductance: 21 mH ref.
- Output Polarity: White lead positive
- Operating Temperature: -73 to +232°C
- Lead Length: 40 in (1 m)
- Net Weight: 2 oz. max.

High Sensitivity - High Temperature

Ordering Part #	Thread Length (A)	
70085-1010-174	.812	(20.62)

Performance Curves

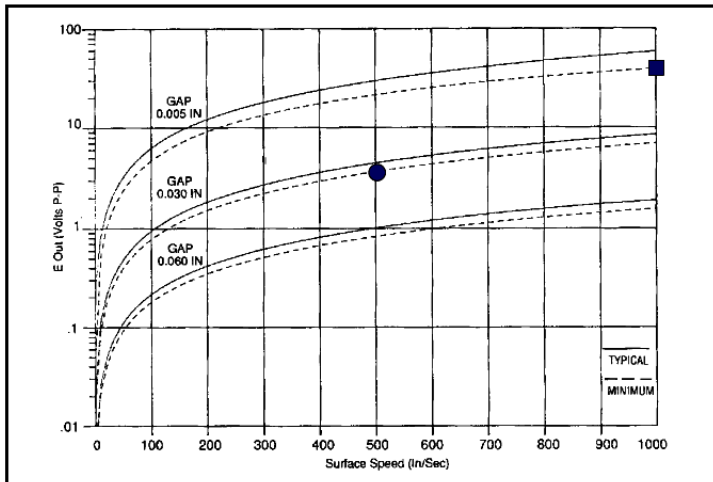

Based on 20 D.P. Gear

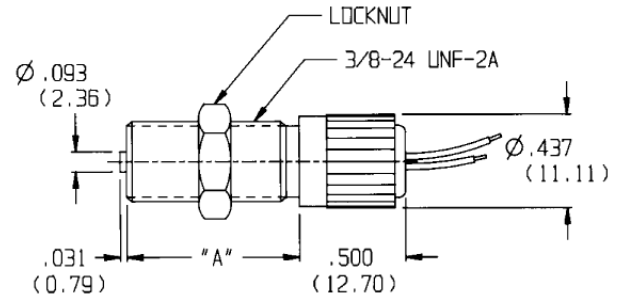

Specifications:

- Output Voltage (Standard): 55 V (P-P)
- Output Voltage (Guarantee Point): 3.6V (P-P)
- DC Resistance: 700 ohms max.
- Typical Inductance: 125 mH ref.
- Output Polarity: White lead positive
- Operating Temperature: -65 to +220°C
- Cable Length: 60 in (1.5 m)
- Net Weight: 2 oz. max.

AI-Tek Instruments, Cheshire, CT USA

Passive Speed Sensors

3/8 – 24 FAMILY

Full Thread – High Sensitivity

Ordering Part # Thread Length (A)
 70085-8080-001 1.500 (38.10)

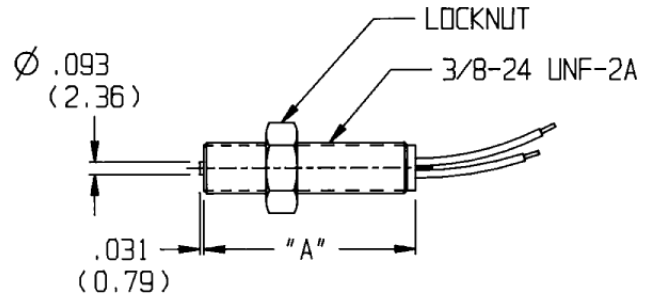

Performance Curves

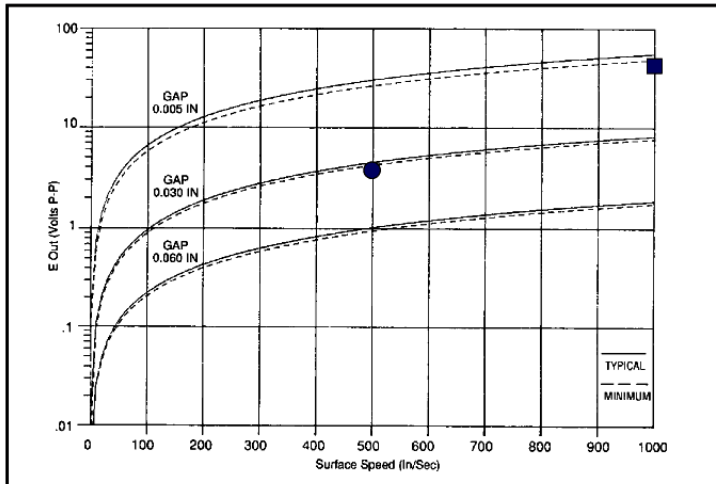

Based on 20 D.P. Gear

Specifications:

- Output Voltage (Standard): 55 V (P-P)
- Output Voltage (Guarantee Point): 4.2 V (P-P)
- DC Resistance: 700 ohms max.
- Typical Inductance: 125 mH ref.
- Output Polarity: White lead positive
- Operating Temperature: -55 to + 107°C
- Lead Length: 6 in (15.2cm)
- Net Weight: 1 oz. max.

Smooth Body – High Sensitivity

Ordering Part # Thread Length (A)
 70085-1010-314 1.375 (34.93)
 70085-8080-004 2.500 (63.50)

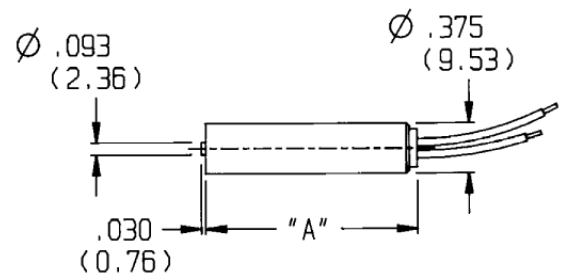

Performance Curves

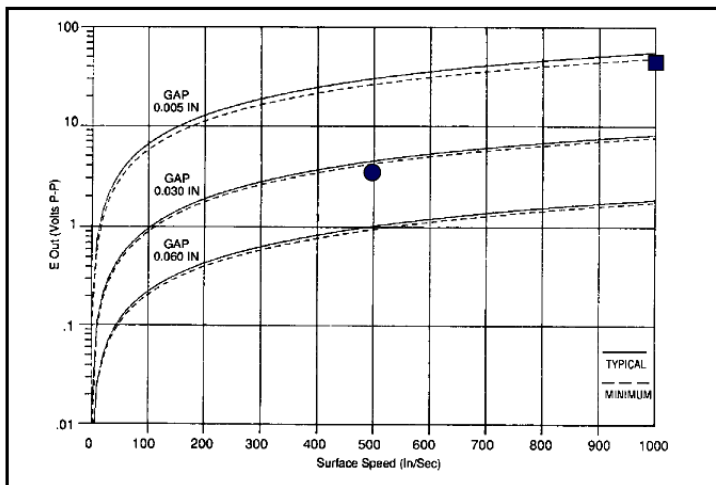

Based on 20 D.P. Gear

Specifications:

- Output Voltage (Standard): 55 V (P-P)
- Output Voltage (Guarantee Point): 4.2 V (P-P)
- DC Resistance: 700 ohms max.
- Typical Inductance: 125 mH ref.
- Output Polarity: White lead positive
- Operating Temperature: -30 to +85°C
- Lead Length: -004, 6 in (15.2cm)
- Cable Length: -314, 10ft (3.05m)
- Net Weight: 3 oz. max.

Al-Tek Instruments, Cheshire, CT USA

Dimensions in inches and (mm).

Passive Speed Sensors

10 - 32 FAMILY

High Sensitivity

Ordering Part #	Thread Length (A)
70085-1010-037	.500 (12.70)
70085-1010-299	1.250 (31.75)

Performance Curves

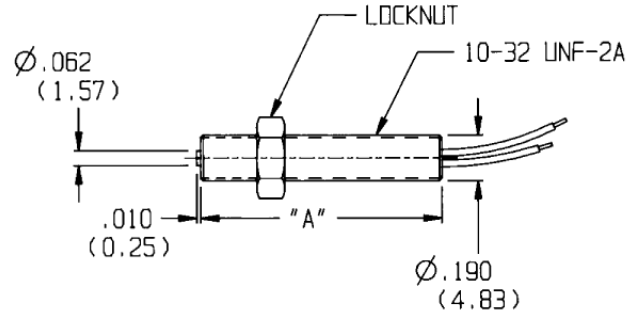
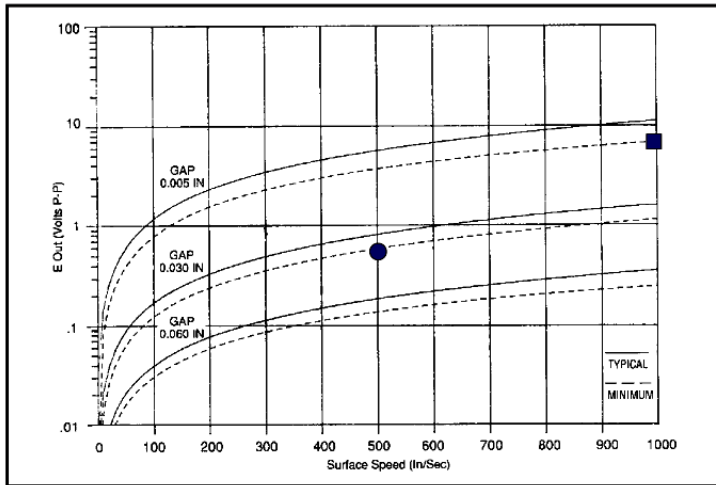

Specifications:

- Output Voltage (Standard): 13 V (P-P)
- Output Voltage (Guarantee Point): .6 V (P-P)
- DC Resistance: 190 ohms max.
- Typical Inductance: 10 mH, ref.
- Output Polarity: White lead positive
- Operating Temperature: -55 to +107°C
- Lead Length: 18 in (45.7 cm)
- Net Weight: 1 oz. max.

General Purpose – High Temperature

Ordering Part #	Thread Length (A)
70085-1010-182	.500 (12.70)
70085-1010-289	1.250 (31.75)

Performance Curves

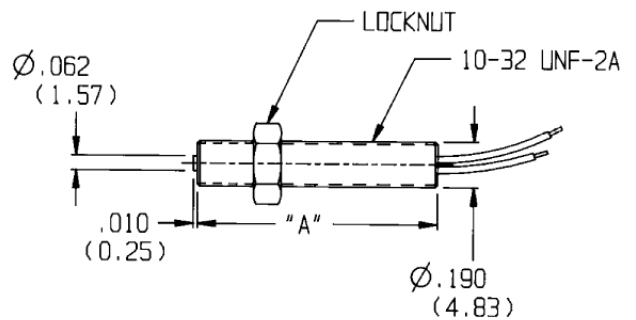
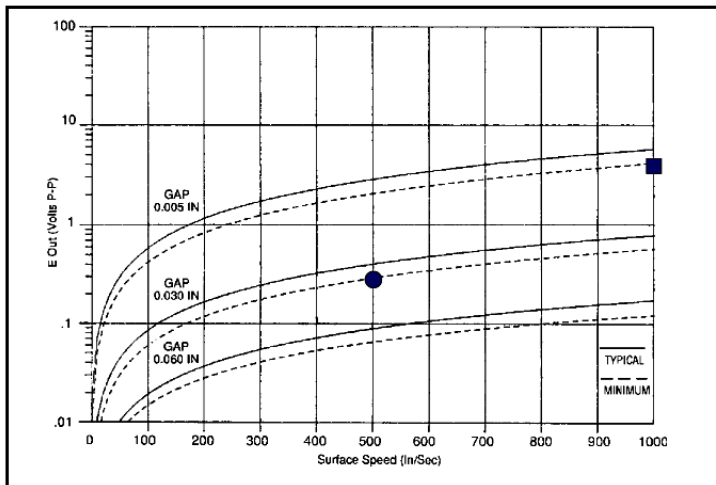

Specifications:

- Output Voltage (Standard): 6 V (P-P)
- Output Voltage (Guarantee Point): .3 V (P-P)
- DC Resistance: 45 ohms max.
- Typical Inductance: 2 mH, ref.
- Output Polarity: White lead positive
- Operating Temperature: -73 to +150°C
- Lead Length: 18 in (45.7 cm)
- Net Weight: 1 oz. max.

Al-Tek Instruments, Cheshire, CT USA

Dimensions in inches and (mm).

UL/CSA Sensors

Ordering Part #	Thread Length (A)	
70085-1010-081	1.500	(38.10)
70085-1010-411	1.875	(47.63)
70085-1010-329	2.750	(69.85)
70085-1010-330	4.000	(101.60)
70085-1010-412	6.000	(152.40)

Rating: UL and CSA listed for hazardous locations. Class I, Div 1, Groups A, B, C & D; Class II, Div 1, Groups E, F, G. Temp Code T3C.

Performance Curves

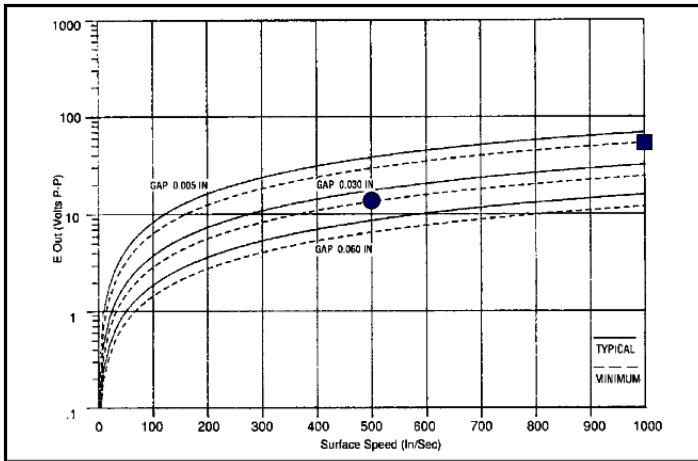

Based on 8 D.P. Gear

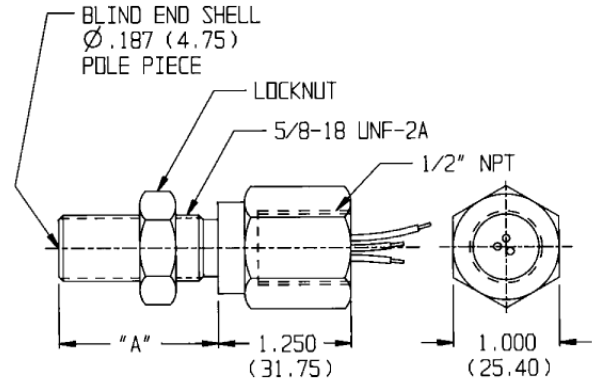

Specifications:

- Output Voltage (Standard): 54 V (P-P)
- Output Voltage (Guarantee Point): 13.4 V (P-P)
- DC Resistance: 240 ohms max.
- Typical Inductance: 30 mH ref.
- Output Polarity: White lead positive
- Operating Temperature: -65 to 100°C
- Lead Length: 10 ft (3.05 m)
- Housing Ground: Green/Yellow Tracer
- Net Weight: 14 oz. max.

UL/CSA Sensors

Ordering Part #	Thread Length (A)	
70085-1010-413	1.500	(38.10)
70085-1010-005	1.875	(47.63)
70085-1010-327	2.750	(69.85)
70085-1010-328	4.000	(101.60)
70085-1010-414	6.000	(152.40)

Rating: UL and CSA listed for hazardous locations. Class I, Div 1, Groups A, B, C & D; Class II, Div 1, Groups E, F, G. Temp Code T3C.

Performance Curves

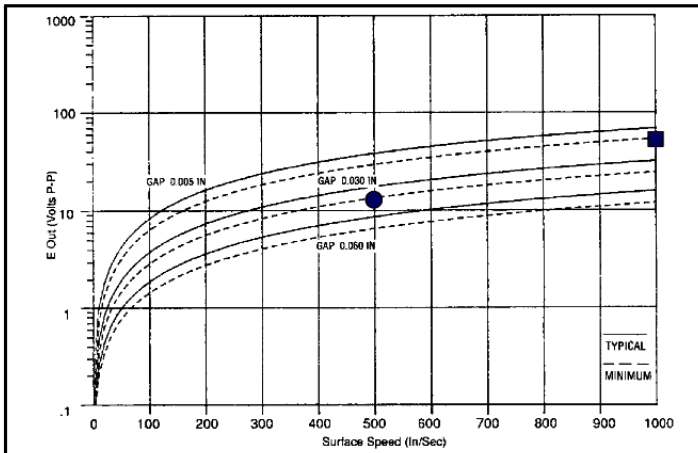

Based on 8 D.P. Gear

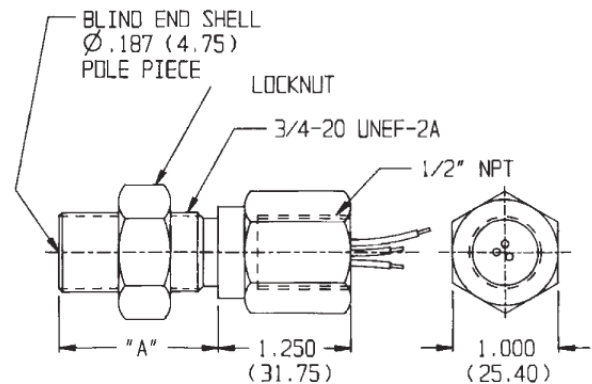

Specifications:

- Output Voltage (Standard): 54 V (P-P)
- Output Voltage (Guarantee Point): 13.4 V (P-P)
- DC Resistance: 240 ohms max.
- Typical Inductance: 30 mH ref.
- Output Polarity: White lead positive
- Operating Temperature: -65 to +100°C
- Lead Length: 10 ft (3.05 m)
- Housing Ground: Green/Yellow Tracer
- Net Weight: 14 oz. max.

Dimensions in inches and (mm).

Passive Speed Sensors

LISTED PRODUCT

FM Sensors

Ordering Part #	Thread Length (A)
70085-1010-404	1.500 (38.10)
70085-1010-406	2.750 (69.85)
70085-1010-417	4.000 (101.60)
70085-1010-420	6.000 (152.40)

Rating: FM listed for hazardous location.
Class I, Div 1, Group D.

Performance Curves

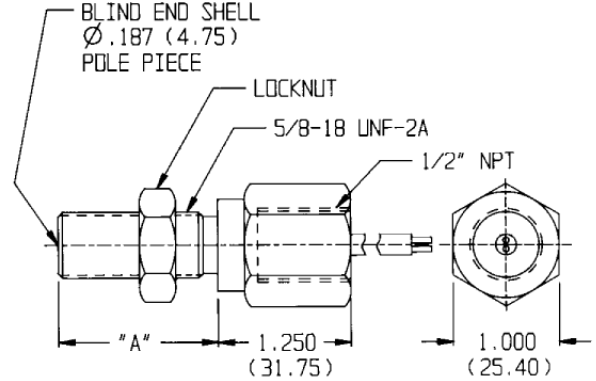
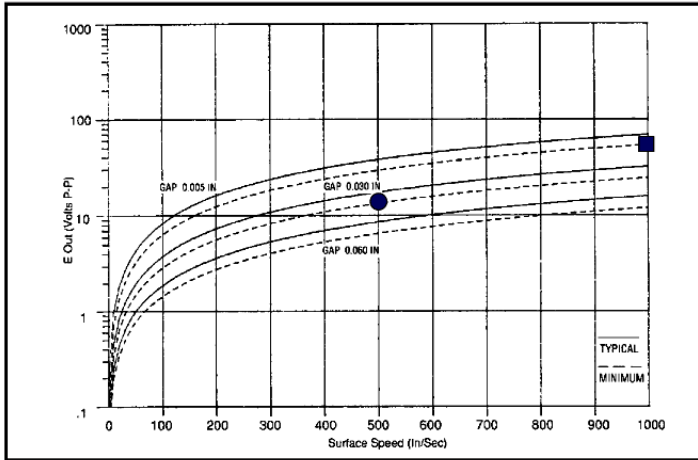

Specifications:

- Output Voltage (Standard): 60V (P-P)
- Output Voltage (Guarantee Point): 13.4V (P-P)
- DC Resistance: 210 ohms max.
- Typical Inductance: 75 mH max.
- Output Polarity: White lead positive
- Operating Temperature: -55 to +220°C
- Cable Length: 15 ft. (4.57m)
- Net Weight: 16 oz. max.

FM Sensors

Ordering Part #	Thread Length (A)
70085-1010-403	1.500 (38.10)
70085-1010-405	2.750 (69.85)*
70085-1010-415	4.000 (101.60)
70085-1010-416	6.000 (152.40)

*3/4 - 20 THD.

Rating: FM listed for hazardous location.
Class I, Div 1, Group D.

Performance Curves

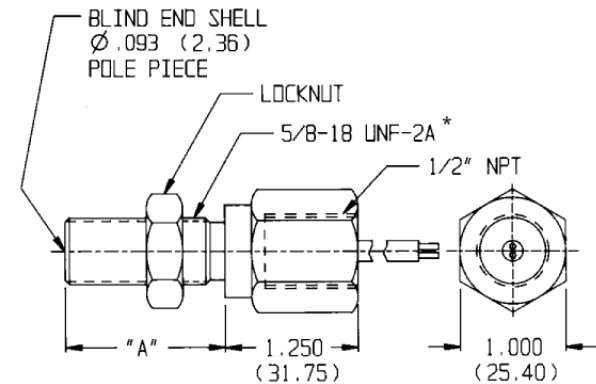
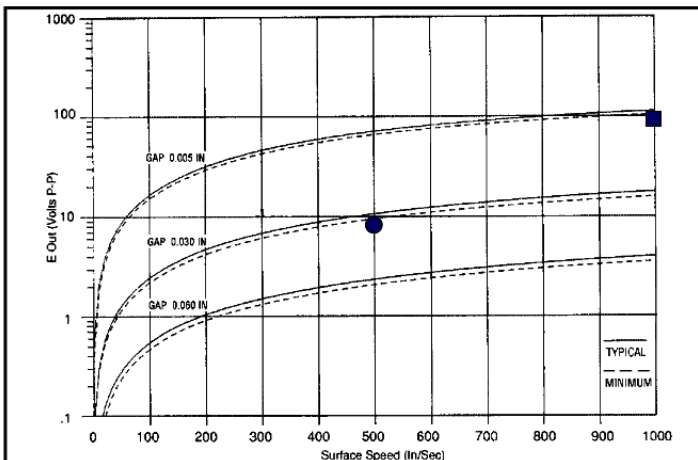

Specifications:

- Output Voltage (Standard): 90 V (P-P)
- Output Voltage (Guarantee Point): 9.4 V (P-P)
- DC Resistance: 750 ohms max.
- Typical Inductance: 210 mH max.
- Output Polarity: White lead positive
- Operating Temperature: -55 to +232° C
- *Mounting Thread: -0405, 3/4 - 20 UNEF-2A
- Cable Length: 15 ft (4.57 m)
- Net Weight: 16 oz. max.

Al-Tek Instruments, Cheshire, CT USA

Dimensions in inches and (mm).

AI-Tek Instruments, LLC

Side Look Sensor

Application: Used for Speed Take Off

The Side Look Sensor (SLS) has been developed by AI-Tek Instruments for Allison automatic transmissions for trucks ranging from light duty vans to over-the-road tractors. It is available for Allison AT, MT and HT transmissions. The new SLS improves on earlier designs developed for Allison to replace a mechanical speed system.

The SLS is a variable reluctance device that provides electronic transmission speed inputs to engine control systems and/or electronic dashboards. It mounts directly on the transmission and employs a unique magnet configuration that induces a magnetic field on the side of the sensor in the path of the rotating transmission gear. This system with its fewer mounting parts improves reliability, reduces weight and conserves space over the earlier designs.

Outline and Mounting Dimensions



The new SLS uses a molded, glass filled nylon body to protect the sensor in harsh, truck-operating environments. It replaces the old fly-lead design with an integral standard Packard connector, which eliminates the added extra connector cost of the old design. It is available in single and dual output versions.

The SLS is manufactured in the United States. AI-Tek Instruments Distributors stock the SLS for off-the-shelf maintenance, repair and overhaul (MRO) requirements.

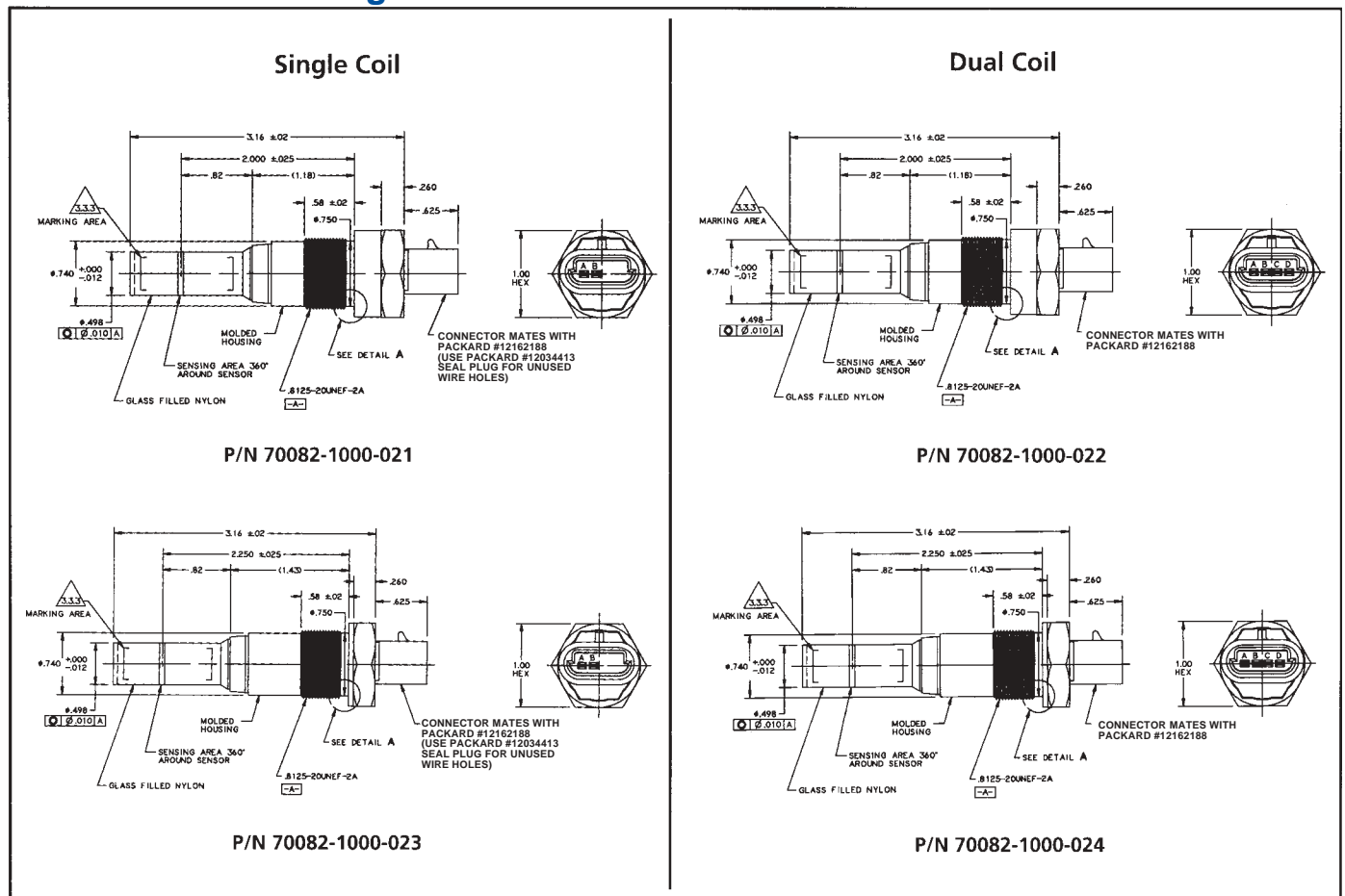

Specifications

Characteristics

Physical

Weight: 55 gm typical.

Body: Black, molded thermoplastic.

Electrical

All measurements at 25°C.

Output:

Single Coil: .67 Volts peak-to-peak, A to B

Dual Coil: .35 Volts peak-to-peak, A to B and C to D,

Sensing a 16 tooth wheel, 2.208" diameter at 100 rpm and .040 inch air gap.

DC Resistance

Single Coil: 3.17K \pm 10% ohms.

Dual Coil: 1206 \pm 20% ohms each coil.

Inductance

Single Coil: 2.25 H typical.

Dual Coil: 620 mH typical.

Dielectric: 1000 VAC between terminals (shorted together) and body for 10 seconds .

.5 mA maximum leakage current.

Environmental

Temperature

Operating Temperature: -40°C to 150°C.

Storage Temperature: -40°C to 150°C.

Connector

Single Coil: Mates with Packard #12162188. (Use

Packard #12034413 seal plug for unused wire holes.)

Dual Coil: Mates with Packard #12162188.

Single Coil

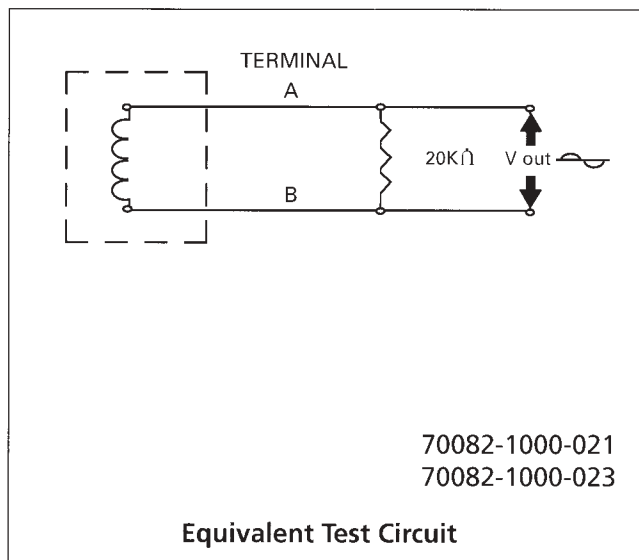

Dual Coil

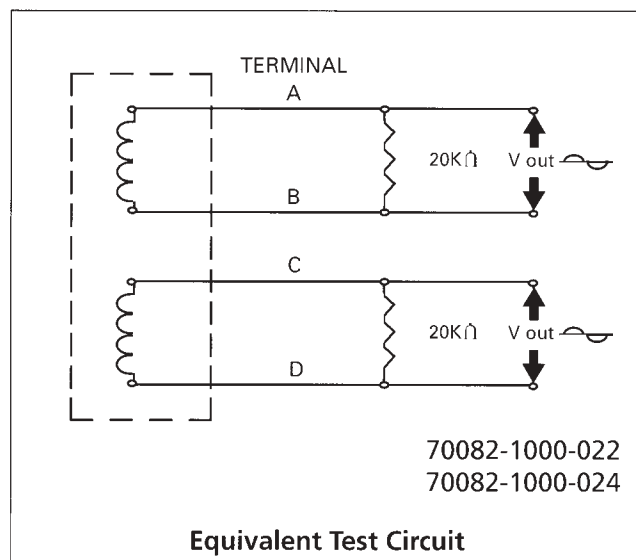

Applications

Applications	
P/N 70082-1000-021	AT, MT
P/N 70082-1000-022	AT, MT
P/N 70082-1000-023	HT
P/N 70082-1000-024	HT



465041

Hall Effect Sensors

AI-Tek has taken its years of experience of designing and manufacturing Hall Effect sensors for engine timing applications and has developed a line of durable products for industrial use.

With multiple standard variations we offer the widest range of standard catalog sensors to meet your various design needs. The design is flexible to easily meet all of your application requirements.

The Hall Effect sensor can sense each change in target movement, regardless of speed, from near zero to 15 kHz frequency range, generating a steady pulse train of frequency proportional to target speed. Typically, each time a gear tooth (or any ferrous discontinuity) passes in front of the sensor the output changes state. This type of sensor is known as a “P” type because it uses N-P-N transistor logic (as opposed to “N” type, which uses P-N-P transistor logic).

Key features to note are:

- Reverse voltage protection, up to -30 Vdc, to prevent damage if miswired
- Higher temperature range of -40°C to +125°C
- Wide range of supply voltage in single design of 4.5 – 24 Vdc
- Two output options of Supply Tracking or TTL Compatible
- Rugged design meeting IEC 77 Standards (European Railroad Applications)

Suitable for 20 diametral pitch or coarser gear (target), the standard catalog sensors are easily applied to your varied sensing needs. If you have a unique, special requirement which cannot be met with any of the standard options, we will gladly review your specs and work with you on a special sensor design.

It is the customer's responsibility to determine whether the product is proper for customer's use and application.

Zero Velocity – Magnetic Hall Effect Sensors – 5/8 and 3/4 Threads

Specifications

Power Supply

Power Supply Voltage:

4.5 – 24 Vdc

Power Supply Current:

50 mA maximum

Outputs

Output Voltage:

Essentially square wave fanout to 10 TTL inputs

TTL Compatible: (See Figure 1)

50% ±30% duty cycle

Logic 0: +.6 Vdc maximum

Logic 1: +4 to +4.6 Vdc @ 5mA

Supply Tracking: (See Figure 2)

50% ±30% duty cycle

Logic 0: +.6 Vdc maximum

Logic 1:
$$V_O = \frac{V_S \times R_L}{R_L + 2.2k}$$

Output Impedance:

2.2K Ohms ±5%

Output Current:

20 mA sink maximum

Output Current - Short Circuit:

5 mA maximum with 10V power supply

Reverse Battery Voltage:

-30 Vdc

Mechanical

Target Frequency:

0 to 15 kHz

Target Air Gap:

.005 to .020 with a 20 diametral pitch gear

.005 to .045 with a 12 diametral pitch gear

.005 to .060 with a 8 diametral pitch gear

Environmental

Operating Temperature:

-40°C to +125°C

Thermal Shock:

100 cycles air to air (-40° to +130°C)

1 min. ramp time with 30 min. soak

Salt Spray:

Per MIL-STD-202, method 201, test cond. B, 5% NaCl for 48 hrs. No visible corrosion

Humidity:

92% RH@ 40°C for 90 hrs. No visible corrosion.

Dielectric Strength:

Per MIL-STD-202, method 301, 1000 Vrms (60Hz) for 5 sec. leads to case. 1.0 mA max. leakage.

Insulation Resistance:

Per MIL-STD-202, method 302, 500 Vdc for 30 sec. leads to case. 100 mega-ohm min.

Vibration:

Per MIL-STD-202, resonant frequency search, sine method 204, test cond. C&D (20g); random method 214a, test cond. A&B (7.56g) for 15 min.

Shock:

Per MIL-STD-202, method 213b (sawtooth), test cond. H&I (100g, 6 ms), 3 shocks, mutually perpendicular planes.

Materials

Housing:

300 series stainless steel

Leads:

AWG #24 Teflon, 200°C

Cable:

AWG #20 Irradiated cross-linked polyolefin, 125°C

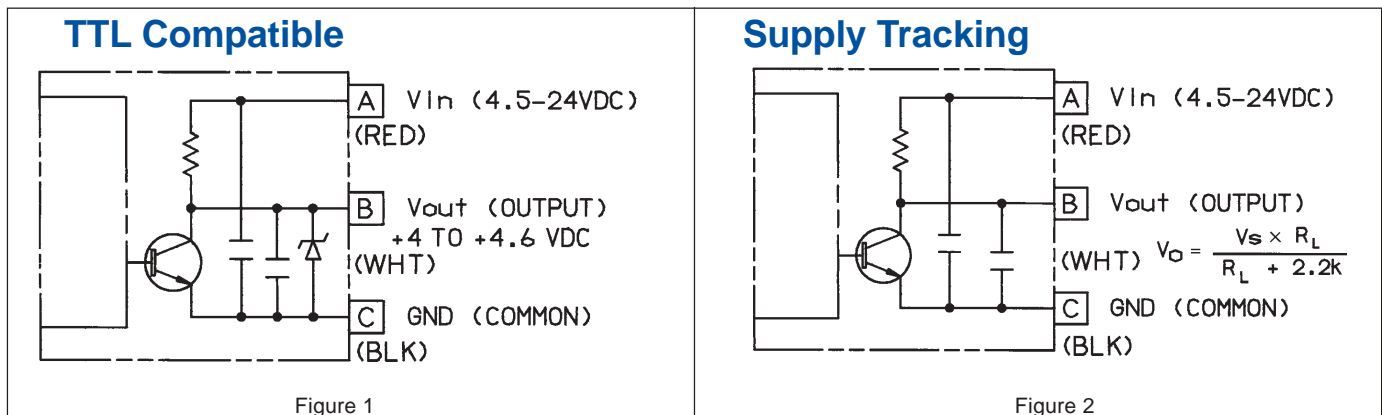

Note: Either output will work with any AI-Tek Tachometer.

Zero Velocity – Magnetic Hall Effect Sensors – 5/8 and 3/4 Threads

Hex Body with Connector

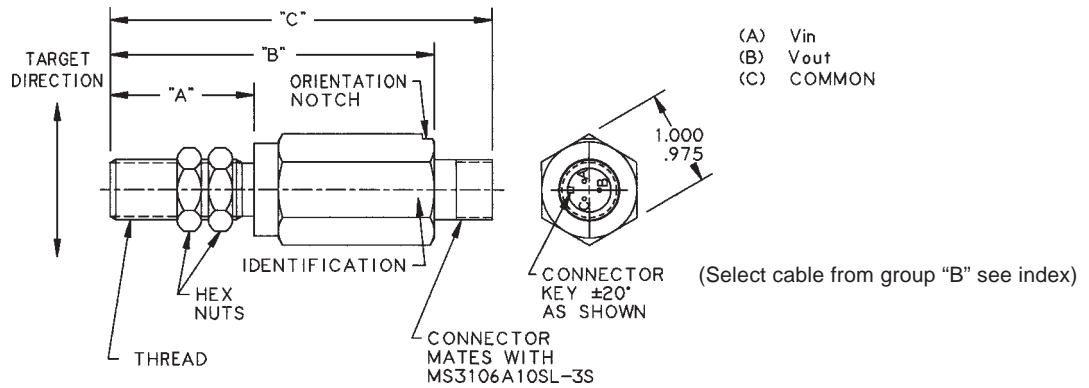

Part Num.	Thread	"A" Dimension	"B" Dimension	"C" Dimension	Output
H1512-001	.625-18 UNF-2A	1.500 (38.100)	3.375 (85.725)	4.012 (101.905)	TTL Compatible
H1522-001	.625-18 UNF-2A	1.500 (38.100)	3.375 (85.725)	4.012 (101.905)	Supply Tracking
H1512-002	.625-18 UNF-2A	2.750 (69.850)	4.625 (117.475)	5.262 (133.655)	TTL Compatible
H1522-002	.625-18 UNF-2A	2.750 (69.850)	4.625 (117.475)	5.262 (133.655)	Supply Tracking
H1612-001	.750-20 UNEF-2A	1.500 (38.100)	3.375 (85.725)	4.012 (101.905)	TTL Compatible
H1622-001	.750-20 UNEF-2A	1.500 (38.100)	3.375 (85.725)	4.012 (101.905)	Supply Tracking
H1612-002	.750-20 UNEF-2A	2.750 (69.850)	4.625 (117.475)	5.262 (133.655)	TTL Compatible
H1622-002	.750-20 UNEF-2A	2.750 (69.850)	4.625 (117.475)	5.262 (133.655)	Supply Tracking

Net Weight: 9 oz. max.

Hex Body with Cable

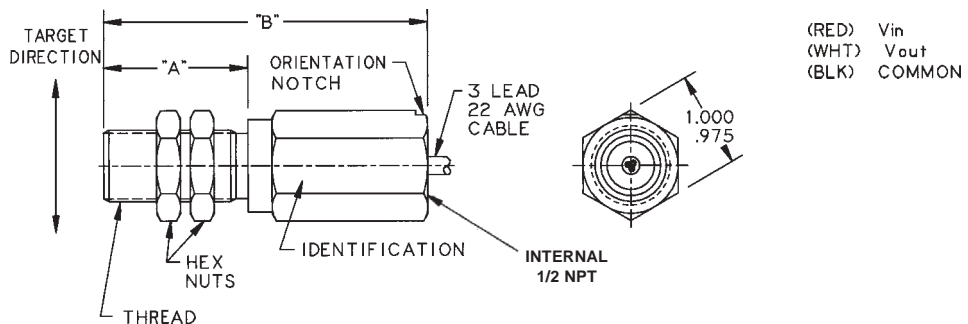

Part Num.	Thread	"A" Dimension	"B" Dimension	Cable Length	Output
H1512-013	.625-18 UNF-2A	1.500 (38.100)	3.375 (85.725)	10 ft (3.05m)	TTL Compatible
H1522-013	.625-18 UNF-2A	1.500 (38.100)	3.375 (85.725)	10 ft (3.05m)	Supply Tracking
H1512-014	.625-18 UNF-2A	2.750 (69.850)	4.625 (117.475)	10 ft (3.05m)	TTL Compatible
H1522-014	.625-18 UNF-2A	2.750 (69.850)	4.625 (117.475)	10 ft (3.05m)	Supply Tracking
H1612-013	.750-20 UNEF-2A	1.500 (38.100)	3.375 (85.725)	10 ft (3.05m)	TTL Compatible
H1622-013	.750-20 UNEF-2A	1.500 (38.100)	3.375 (85.725)	10 ft (3.05m)	Supply Tracking
H1612-014	.750-20 UNEF-2A	2.750 (69.850)	4.625 (117.475)	10 ft (3.05m)	TTL Compatible
H1622-014	.750-20 UNEF-2A	2.750 (69.850)	4.625 (117.475)	10 ft (3.05m)	Supply Tracking

Net Weight: 9 oz. max.

Zero Velocity – Magnetic Hall Effect Sensors – 5/8 and 3/4 Threads

Round Body with Connector

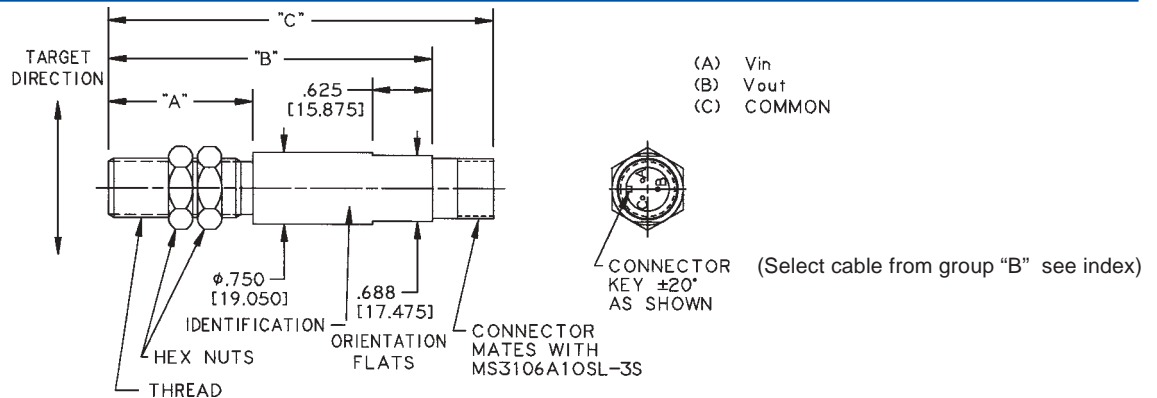

Part Num.	Thread	"A" Dimension	"B" Dimension	"C" Dimension	Output
H1512-005	.625-18 UNF-2A	1.500 (38.100)	3.375 (85.725)	4.012 (101.905)	TTL Compatible
H1522-005	.625-18 UNF-2A	1.500 (38.100)	3.375 (85.725)	4.012 (101.905)	Supply Tracking
H1512-006	.625-18 UNF-2A	2.750 (69.850)	4.625 (117.475)	5.262 (133.655)	TTL Compatible
H1522-006	.625-18 UNF-2A	2.750 (69.850)	4.625 (117.475)	5.262 (133.655)	Supply Tracking
H1512-007	.625-18 UNF-2A	4.000 (101.600)	5.875 (149.225)	6.512 (165.405)	TTL Compatible
H1522-007	.625-18 UNF-2A	4.000 (101.600)	5.875 (149.225)	6.512 (165.405)	Supply Tracking
H1612-005	.750-20 UNEF-2A	1.500 (38.100)	3.375 (85.725)	4.012 (101.905)	TTL Compatible
H1622-005	.750-20 UNEF-2A	1.500 (38.100)	3.375 (85.725)	4.012 (101.905)	Supply Tracking
H1612-006	.750-20 UNEF-2A	2.750 (69.850)	4.625 (117.475)	5.262 (133.655)	TTL Compatible
H1622-006	.750-20 UNEF-2A	2.750 (69.850)	4.625 (117.475)	5.262 (133.655)	Supply Tracking
H1612-007	.750-20 UNEF-2A	4.000 (101.600)	5.875 (149.225)	6.512 (165.405)	TTL Compatible
H1622-007	.750-20 UNEF-2A	4.000 (101.600)	5.875 (149.225)	6.512 (165.405)	Supply Tracking

Net Weight: 7 oz. max.

Fully Threaded with Leads

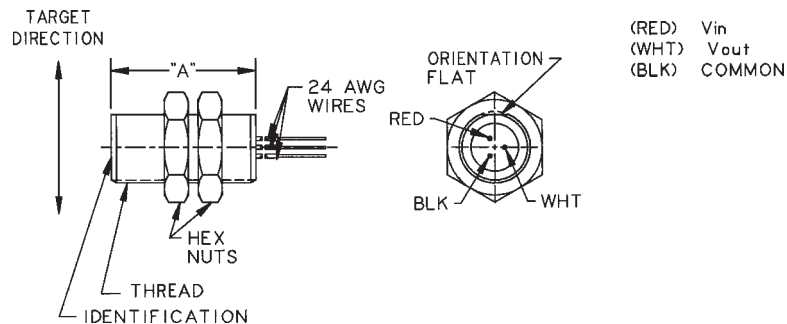

Part Num.	Thread	"A" Dimension	Lead Length	Output
H1512-009	.625-18 UNF-2A	1.500 (38.100)	12 (304)	TTL Compatible
H1522-009	.625-18 UNF-2A	1.500 (38.100)	12 (304)	Supply Tracking
H1512-010	.625-18 UNF-2A	2.750 (69.850)	12 (304)	TTL Compatible
H1522-010	.625-18 UNF-2A	2.750 (69.850)	12 (304)	Supply Tracking
H1612-009	.750-20 UNEF-2A	1.500 (38.100)	12 (304)	TTL Compatible
H1622-009	.750-20 UNEF-2A	1.500 (38.100)	12 (304)	Supply Tracking
H1612-010	.750-20 UNEF-2A	2.750 (69.850)	12 (304)	TTL Compatible
H1622-010	.750-20 UNEF-2A	2.750 (69.850)	12 (304)	Supply Tracking

Net Weight: 3 oz. max.

Zero Velocity – Magnetic Hall Effect Sensors – 5/8 and 3/4 Threads

UL/CSA Explosion Proof Sensors

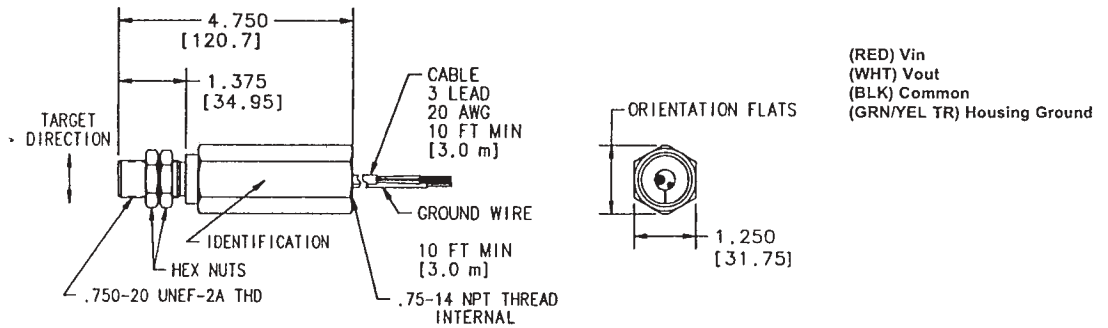

Part Num.	Thread	Thread Length	Overall Length	Cable Length	Output
H1612-025	.750-20 UNEF-2A	1.375 (34.92)	4.750 (120.65)	10 ft. (3.0 m)	TTL Compatible

Rating: UL & CSA listed for hazardous locations. Class I, Div. 1, Groups A, B, C & D; Class II, Div., 1, Groups E, F & G. Temp Code T4A. Connect only to NEC Class 2 circuits.
 Net Weight: 23 oz. max.

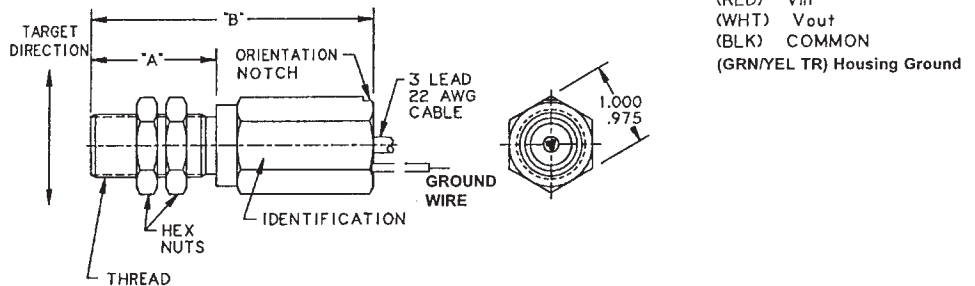

Part Num.	Thread	"A" Dimension	"B" Dimension	Cable Length	Output
H1512-026	.625-18 UNF-2A	1.500 (38.100)	3.375 (85.725)	10 ft (3.05m)	TTL Compatible
H1522-013	.625-18 UNF-2A	1.500 (38.100)	3.375 (85.725)	10 ft (3.05m)	Supply Tracking
H1512-014	.625-18 UNF-2A	2.750 (69.850)	4.625 (117.475)	10 ft (3.05m)	TTL Compatible
H1522-014	.625-18 UNF-2A	2.750 (69.850)	4.625 (117.475)	10 ft (3.05m)	Supply Tracking
H1612-013	.750-20 UNEF-2A	1.500 (38.100)	3.375 (85.725)	10 ft (3.05m)	TTL Compatible
H1622-013	.750-20 UNEF-2A	1.500 (38.100)	3.375 (85.725)	10 ft (3.05m)	Supply Tracking
H1612-014	.750-20 UNEF-2A	2.750 (69.850)	4.625 (117.475)	10 ft (3.05m)	TTL Compatible
H1622-014	.750-20 UNEF-2A	2.750 (69.850)	4.625 (117.475)	10 ft (3.05m)	Supply Tracking

Rating: UL & CSA listed for hazardous locations. Class I, Div. 1, Groups A, B, C & D; Class II, Div., 1, Groups E, F & G. Temp Code T4A. Connect only to NEC Class 2 circuits.
 Net Weight: 9 oz. max.

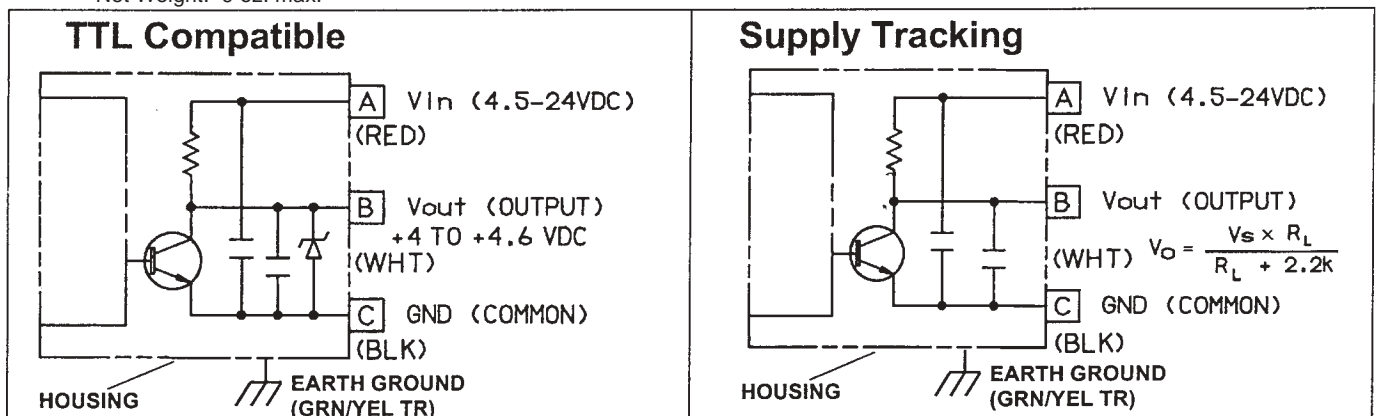

AI-Tek Instruments, Cheshire, CT USA

Dimensions in inches and (mm).

Zero Velocity – Magnetic Hall Effect Sensors – 3/8 Diameter

Specifications

Power Supply

Power Supply Voltage:

4.5 – 24 Vdc

Power Supply Current:

50 mA maximum

Outputs

Output Voltage:

Essentially square wave fanout to 10 TTL inputs

Supply Tracking: (See Figure 1)

50% ±30% duty cycle

Logic 0: +.6 Vdc maximum

Logic 1:
$$V_O = \frac{V_S \times R_L}{R_L + 2.2k}$$

Output Impedance:

2.2K Ohms ±5%

Output Current:

20 mA sink maximum

Output Current - Short Circuit:

5 mA maximum with 10V power supply

Reverse Battery Voltage:

-30 Vdc

Mechanical

Target Frequency:

0 to 15 kHz

Target Air Gap:

.000 to .015 with a 20 diametral pitch gear

.000 to .040 with a 12 diametral pitch gear

.000 to .055 with a 8 diametral pitch gear

Environmental

Operating Temperature:

-25°C to +125°C (105°C Cable)

Materials

Housing:

300 series stainless steel

Leads:

AWG #24 Teflon, 200°C

Cable:

AWG #26 PVC, 105°C

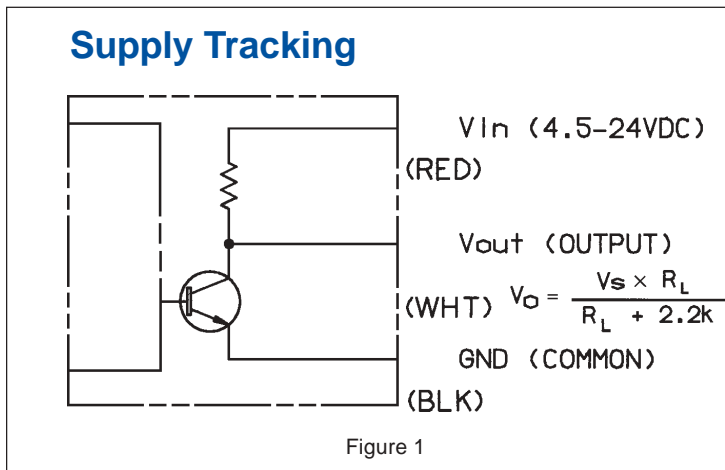

Note: Will work with any AI-Tek Tachometer.

Zero Velocity – Magnetic Hall Effect Sensors – 3/8 Diameter

Fully Threaded

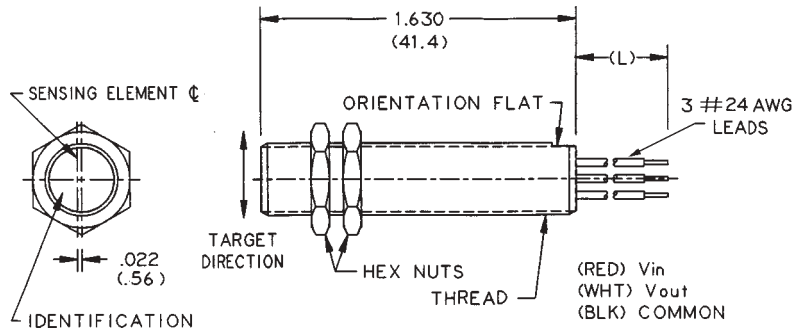

Part Num.	Thread	Cable Length (C)	Lead Length (L)
H1320-001	.375-32 UNEF-2A	—	12 (304)
H1320-003	.375-32 UNEF-2A	10 ft. (3.05 m)	—
H1320-009	.375-24 UNF-2A	—	12 (304)
H1320-010	.375-24 UNF-2A	10 ft. (3.05 m)	—

Net Weight: 0.7 oz. max.

Round Body

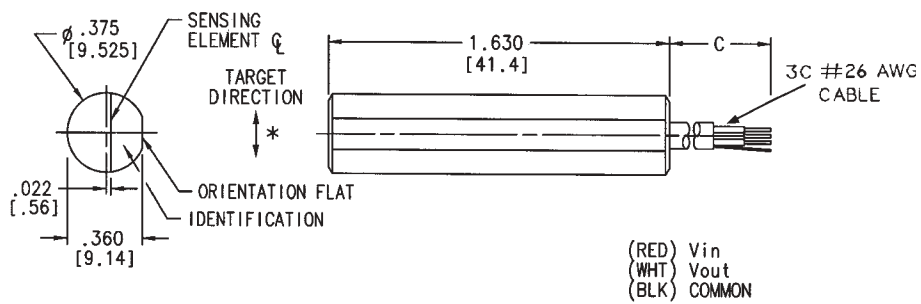

Part Number	Cable Length (C)	Lead Length (L)
H1320-005	—	12 (304)
H1320-006	10 ft (3.05 m)	—

Net Weight: 0.5 oz. max.

* Note difference in target direction with regard to flat (vs. threaded sensor).

Dimensions in inches and (mm).

Bi-Directional, Dual Channel, Hall Effect Speed Sensors

AI-Tek bi-directional, zero velocity sensors are self-calibrating to the specific customer application and provide two independent frequency outputs and a direction signal output to indicate change in direction of the sensed, ferrous target.

The bi-directional sensor can also be referred to as a dual channel sensor since it utilizes two Hall effect sensing elements, physically offset from each other. Each element generates a single channel of target information, identical in frequency and polarity, but offset in the time domain (phase shifted). Special circuits inside the sensor are designed to calibrate each channel to its application target, then analyze these two channels of information for a phase lead / lag condition. The direction output will then provide a logic 1 level for clockwise or a logic 0 level for counterclockwise rotation, assuming proper sensor orientation.

UL/CSA/ATEX

AI-Tek will be pursuing UL/CSA/ATEX approval for its line of Bi-Directional, Dual Channel, Hall Effect speed sensors.

Please contact Factory or Distributor for the status of this approval.

It is the customer's responsibility to determine whether the product is proper for customer's use and application.

Bi-Directional, Dual Channel, Hall Effect Speed Sensors

Cable	5 conductor, 22 AWG irradiated cross-linked polyolefin	
Connector (mates with)	Bendix PT06W-10-6S or Souriau 851-06J10-6S50	
Housing Material	300 series stainless steel	
Voltage**	10 to 28 vdc	
Current	100mA max.	
Output impedance	2.2KΩ	
Outlook Logic levels	Logic 0	Logic 1
TTL	0.6 vdc. Max.	4.5 +/-0.5 vdc @ 5mA.
ST (Supply Tracking)	0.6 vdc. Max.	$V_o = V_s(R_L / (R_L + 2.2K\Omega))$
Direction logic	Output high (logic 1) with direction of rotation towards notch	
Output current	Source = 1.0mA max., Sink = 20mA max.	
Frequency	DC to 15KHz	
Rise/Fall time	5μS / 3μS typical	
Duty Cycle	40% to 60%	
Channel phasing (quadrature)**	45° to 135°	
Gear pitch vs. airgap**	8 - 32DP, .005" - .080" air gap / 3.2 - .79Mod., 0.13 – 2 mm	
Operating temperature	-40°C to +125°C	
Environmental <ul style="list-style-type: none"> • Thermal Shock • Salt Spray • Humidity • Dielectric Strength • Insulation Resistance • Vibration • Shock 	Design principles consistent with "H" series Hall Effect Sensors to withstand severe environmental stresses.	
EMC <ul style="list-style-type: none"> • Conducted emissions and susceptibility • Radiated emissions and susceptibility • Transients 	Design principles consistent with BS/EN and MIL-STD's for EMC hardness.	

**Consult factory for application assistance.

Al-Tek Instruments, Cheshire, CT USA

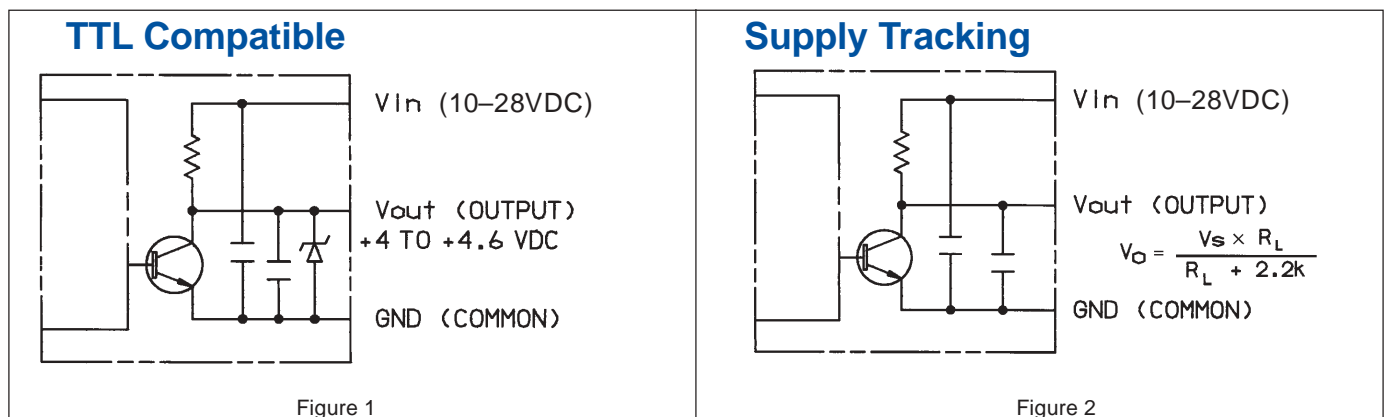

Note: Either output will work with any Al-Tek Tachometer.

Bi-Directional, Dual Channel, Hall Effect Speed Sensors - 5/8 and 3/4 Threads

Bi-Directional, Hex Body with 6 Pin Connector

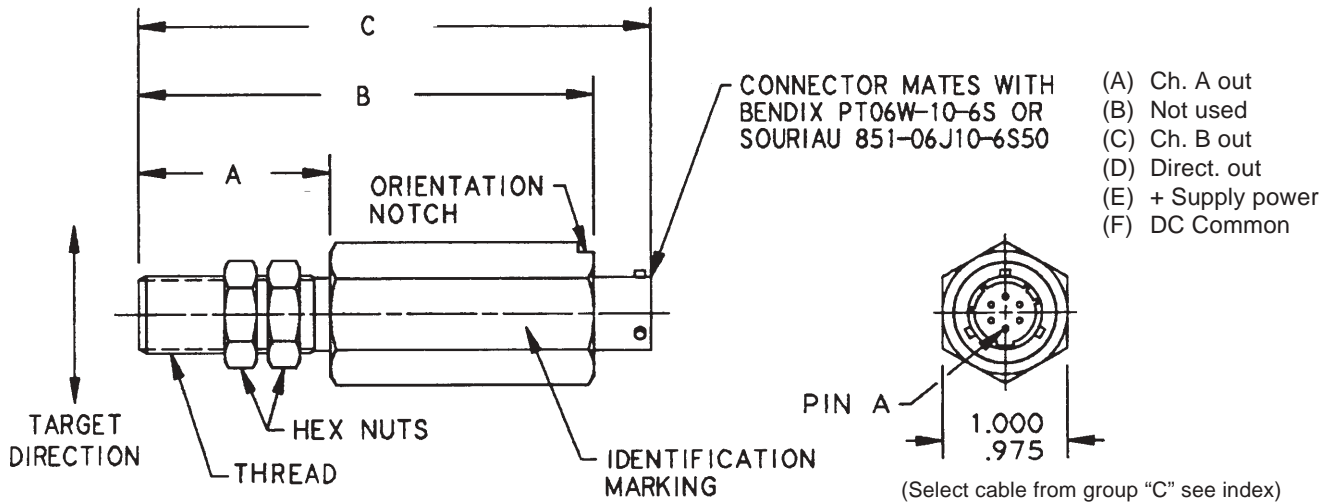

Part Num.	Thread	"A" Dim.	"B" Dim.	"C" Dim. (max.)	Output
BH1512-001	.625-18UNF-2A	1.500 (38.1)	3.375 (85.7)	3.875 (98.4)	TTL Compatible
BH1522-001					Supply Tracking
BH1512-002		2.750 (69.9)	4.625 (117.5)	5.125 (130.2)	TTL Compatible
BH1522-002					Supply Tracking
BH1612-001	.750-20UNEF-2A	1.500 (38.1)	3.375 (85.7)	3.875 (98.4)	TTL Compatible
BH1622-001					Supply Tracking
BH1612-002		2.750 (69.9)	4.625 (117.5)	5.125 (130.2)	TTL Compatible
BH1622-002					Supply Tracking

Bi-Directional, Hex Body with Cable

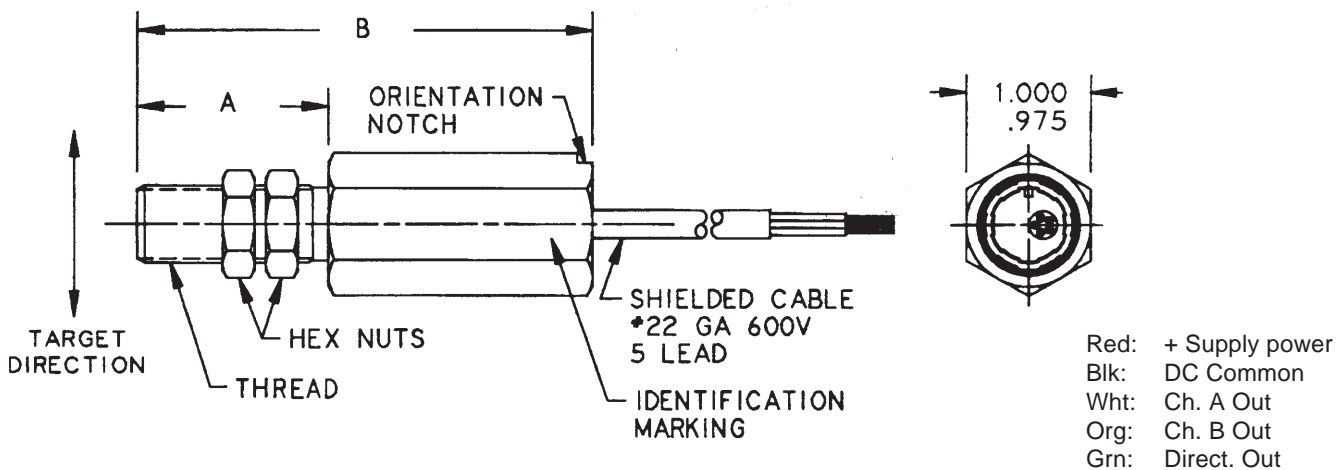

Part Num.	Thread	"A" Dim.	"B" Dim.	Cable Length	Output
BH1512-013	.625-18UNF-2A	1.500 (38.1)	3.375 (85.7)	10 ft. (3.05m)	TTL Compatible
BH1522-013					Supply Tracking
BH1512-014		2.750 (69.9)	4.625 (117.5)		TTL Compatible
BH1522-014					Supply Tracking
BH1612-013	.750-20UNEF-2A	1.500 (38.1)	3.375 (85.7)	10 ft. (3.05m)	TTL Compatible
BH1622-013					Supply Tracking
BH1612-014		2.750 (69.9)	4.625 (117.5)		TTL Compatible
BH1622-014					Supply Tracking

Bi-Directional, Dual Channel, Hall Effect Speed Sensors - 5/8 and 3/4 Threads

Bi-Directional, Round Body with Connector

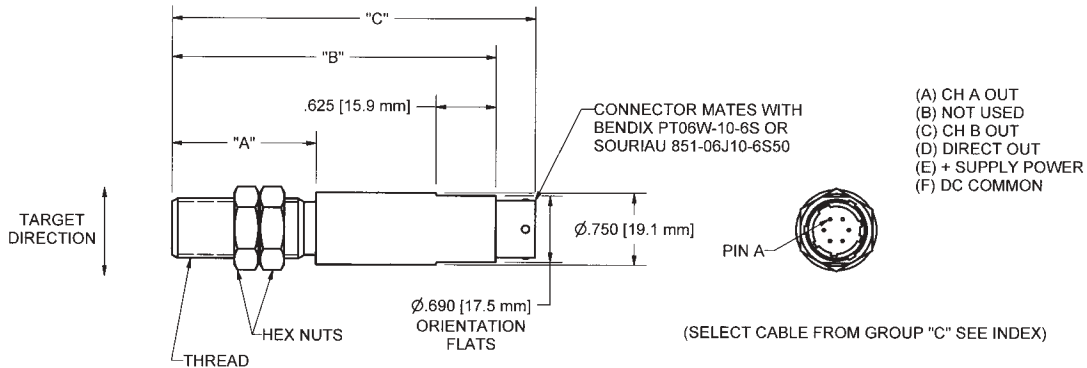

Part Num.	Thread	"A" Dim.	"B" Dim.	"C" Dim. (max.)	Output
BH1512-005	.625-18 UNF-2A	1.500 (38.1)	3.375 (85.7)	3.875 (98.4)	TTL Compatible
BH1522-005					Supply Tracking
BH1512-006		2.750 (69.9)	4.625 (117.5)	5.125 (130.2)	TTL Compatible
BH1522-006					Supply Tracking
BH1612-005	.750-20 UNEF-2A	1.500 (38.1)	3.375 (85.7)	3.875 (98.4)	TTL Compatible
BH1622-005					Supply Tracking
BH1612-006		2.750 (69.9)	4.625 (117.5)	5.125 (130.2)	TTL Compatible
BH1622-006					Supply Tracking

Bi-Directional, Fully Threaded with Cable

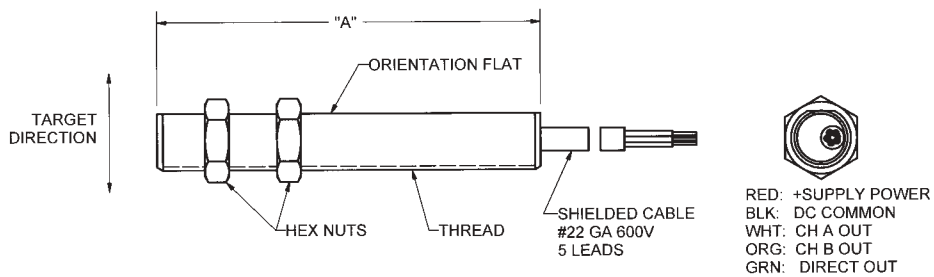

Part Num.	Thread	"A" Dim.	Cable Length	Output
BH1512-009	.625-18 UNF-2A	4.000 (101.6)	10 ft. (3.05m)	TTL Compatible
BH1522-009				Supply Tracking
BH1512-010	6.000 (152.4)			TTL Compatible
BH1522-010				Supply Tracking
BH1612-009	.750-20 UNEF-2A	4.000 (101.6)		TTL Compatible
BH1622-009				Supply Tracking
BH1612-010	6.000 (152.4)			TTL Compatible
BH1622-010				Supply Tracking

Dimensions in inches and (mm).

Connectors and Cable Assemblies

AI-Tek stocks a selection of connectors and cable assemblies for your convenience. For ease of selection, the connectors and assemblies are divided into groups. Group "A" is designed for 2-wire items, Group "B" for 3-wire.

Complete cable assemblies include the connector and 10' of recommended wiring for use with AI-Tek equipment. All wiring is insulated, spirally wrapped in a tinned copper shield and jacketed in long-lasting PVC or polyolefin insulation. Alternate cable length is available for special requests.



Group		A-I Tek P/N	Mil. Connect. No.	Max. Temp.	Cable Wiring
A	S	CN79860 -3100	MS3106A10SL-4S	125°C	Connector Only
	R	-3800	MS3108B10SL-4S	125°C	Connector Only
	S	-3000	MS3106A10SL-4S	182°C	Connector Only
	S	CA79860 -01-00	MS3106A10SL-4S	80°C	2 #22 Black & Red
	R	-17-00	MS3108B10SL-4S	80°C	2 #22 Black & Red
	S	-06-00	MS3106A10SL-4S	182°C	2 #20 Black & White
B	S	CN79860 -2600	MS3106A10SL-3S	125°C	Connector Only
	R	-3900	MS3108B10SL-3S	125°C	Connector Only
	S	CA79860 -18-00	MS3106A10SL-3S	125°C	3 #20 Red, White & Black
	R	-24-00	MS3108B10SL-3S	125°C	3 #20 Red, White & Black
C	S	CN79860 -4200	MIL-C-26482	125°C	Connector Only
	S	CA79861-30-00	Bayonet Style	125°C	5#22 Red, Orange, Black, White, Green

Net Weight: 5 oz. max.

Standard cable assemblies include 10ft. of shielded cable. For other cable length contact your local distributor.

S = Straight Connector

R = Right Angle Connector

It is the customer's responsibility to determine whether the product is proper for customer's use and application.

Groups A & B (Straight)

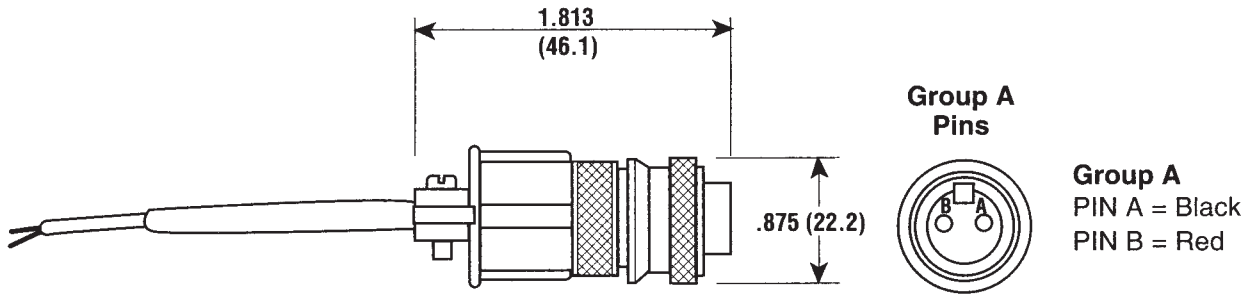

Groups A & B (Right Angle)

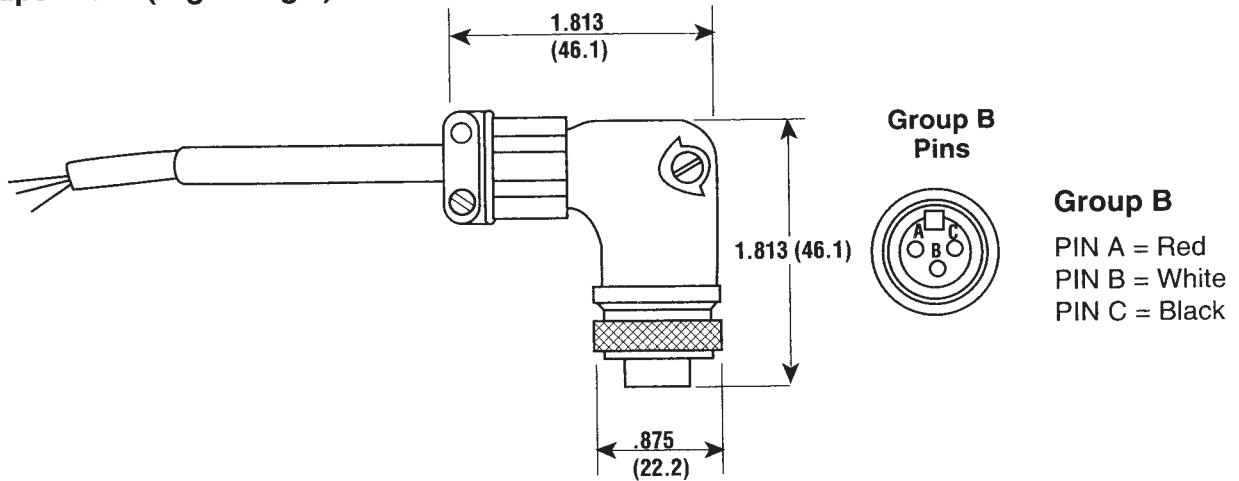

Group C

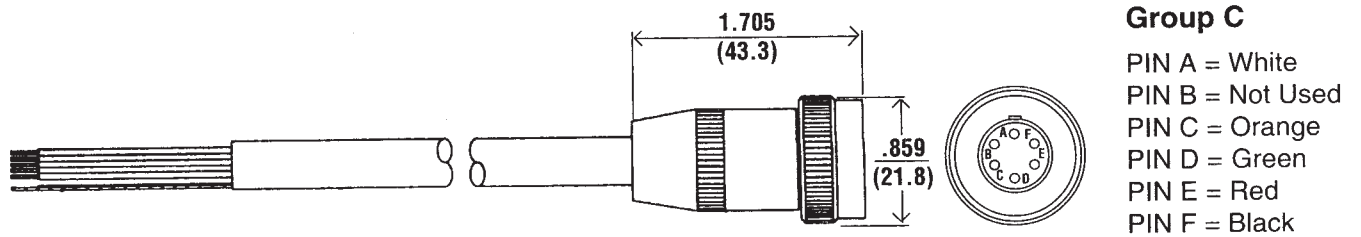

Split Gears

When using an AI-Tek speed sensor in RPM measurement, split gears provide a convenient and simple means of installation where shaft disassembly is not feasible. The two halves of the gear are fastened with clamping screws, thus assuring close fit. All split gears are 12 diametral pitch, 14.5° pressure angle.



Solid Gear

AI-Tek also offers a 20 diametral pitch, 14.5° pressure angle, solid steel gear. This gear can be rebored to fit shaft diameters up to 1.375". It is secured to the shaft with 2 set screws.

Note: Gears are supplied with minimum bores as shown. Alternate bores within the minimum and maximum limits are available at additional cost.

Caution: Gears may shatter if not installed to specifications or if operated above maximum RPM.

Dimensions of Steel Split Gears									
Part No.	Pitch Dia., In.	O.D. Inches	No. of Teeth	Tooth Face, In.	Overall Length, In.	Std. Bore Dia., In.	Max. Bore Dia., In.	Approx. Wt., Lbs.	Max. RPM
G79870-202-1800	4.000	4.166	48	.312	1.000	0.500	2.125	3.0	8400
G79870-202-1901	5.000	5.166	60	.312	1.000	1.000	3.125	5.0	5900
G79870-202-2001	6.000	6.166	72	.312	1.000	1.000	4.000	7.0	5900
G79870-202-2101	8.000	8.166	96	.312	1.125	1.000	5.750	15.0	4500
G79870-202-2201	10.000	10.166	120	.312	1.250	1.000	7.500	26.0	3000
G79870-202-4233	15.000	15.166	180	.375	1.375	7.500	12.000	48.0	2400
Dimensions of Solid Steel Gear									
G79870-202-0967	3.000	3.100	60	.375	0.875	0.375	1.375	1.2	6000

Steel Split Gear

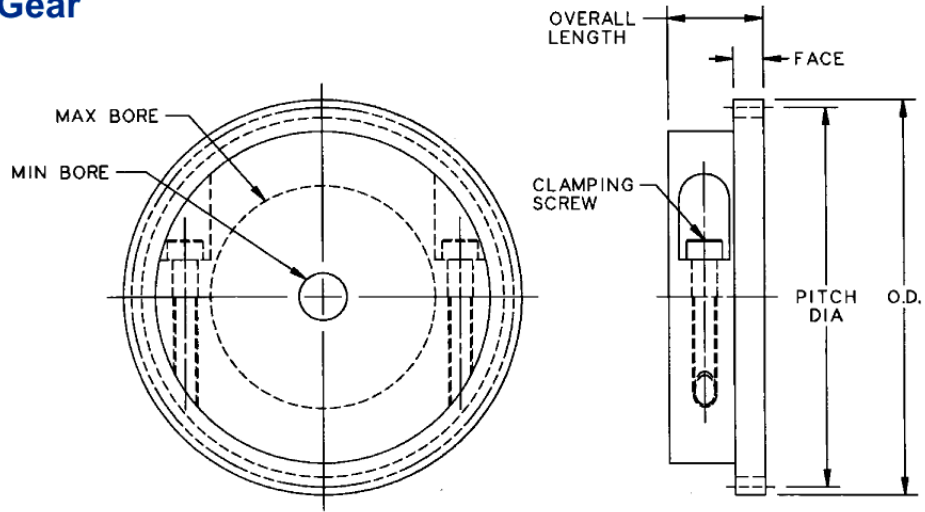

Solid Steel Gear

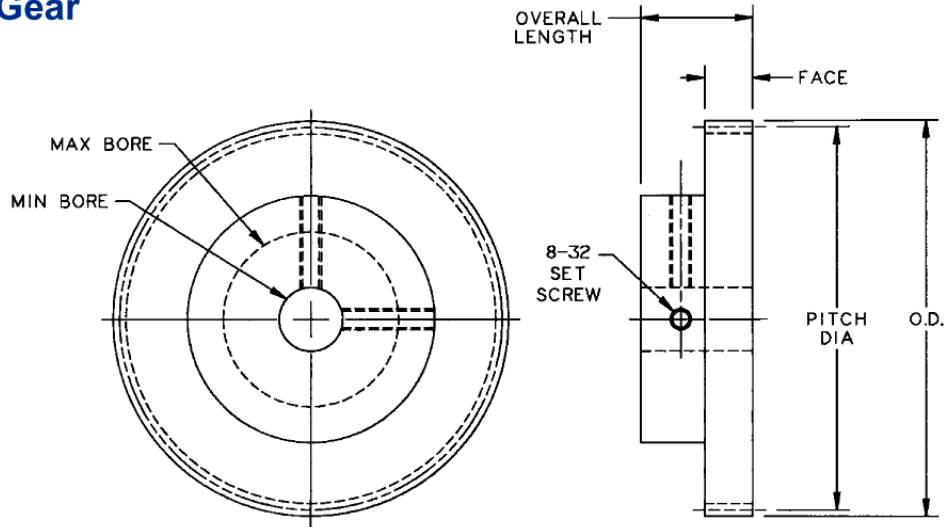



Tachometer Transducers

AI-Tek tachometer transducers are self-generating units when used with speed sensors. They are designed primarily to provide an easy means of attaching a pulse generating assembly to rotating shafts. Sensor gapping, shaft run-out and mounting problems are eliminated. This makes the unit especially useful for shafts with high run-out. The ordering map on the following page provides information for selecting a unit for your particular application. Please note that sensors and cable assemblies must be ordered separately.

Taper-Lock® Type

The assembly consists of a Taper-Lock bushing which enables quick attachment to rotating shafts. The transducer employs a rotor with small perforations along its periphery; a permanently lubricated sealed bearing; an outer ring and a reference rod which, when clamped in position, prevents the outer ring assembly from moving. The outer ring can accommodate up to three speed sensors for use in monitoring directions of rotation and speed.

Sleeve Type

The AI-Tek sleeve-type transducer assembly is identical to the Taper-Lock type except that it provides a sleeve bushing with two set screws for installation purposes, allowing larger shaft sizes.

Mechanical Specifications

Lubrication: Bearings are permanently lubricated; do not use pressure washes or solvents.

Finish: Reference rod and outer ring are anodized aluminum.

Reference Rod: 1/4" diameter, 6" long

Bearing Limits: 4000 RPM max. speed

Weight: 54 oz. (1.53 kg) max.

Sensor Mounting: 5/8-18 UNF-2A threaded hole std.

Electrical Specifications

Output Frequency: 30 pulses/rev. (1 Hz = 2RPM), Standard; 60 pulses/rev. (1 Hz = 1RPM), Optional.

Output Voltage: Depends on magnetic sensor used. One turn of sensor controls 0.056 inches of air gap based on 5/8-18 UNF-2A thread. Normal gap setting range from 0.005 to 0.020 inches.

Ambient Temperature: -30°C to +50°C

NOTE: *Not for use in abrasive atmospheres.*

It is the customer's responsibility to determine whether the product is proper for customer's use and application.

Ease of Installation

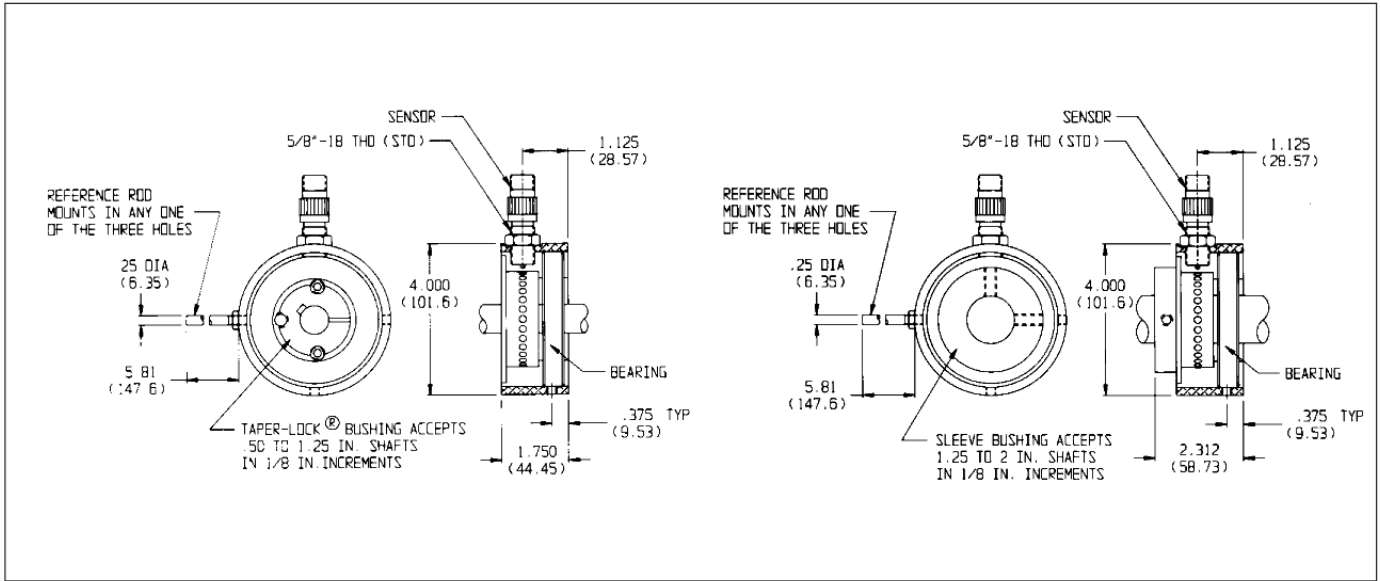

Ordering Map

T79850-103-

- Basic Model**
1. Tachometer Transducer to accommodate one sensor, 30 pulses/rev. (standard)
 2. Tachometer Transducer to accommodate two sensors, 30 pulses/rev.
 4. Tachometer Transducer to accommodate one sensor, 60 pulses/rev.
 5. Tachometer Transducer to accommodate two sensors, 60 pulses/rev.

- Bearing/Bushing Type**
2. Taper-Lock bushing & sealed bearing

or

4. Sleeve bushing & sealed bearing

- Bore Size**
- 11 - Bore Diameter 1/2"
 - 12 - Bore Diameter 5/8"
 - 13 - Bore Diameter 3/4"
 - 14 - Bore Diameter 7/8"
 - 15 - Bore Diameter 1"
 - 16 - Bore Diameter 1 1/8"
 - 17 - Bore Diameter 1 1/4"

or

- 18 - Bore Diameter 1 3/8"
- 19 - Bore Diameter 1 1/2"
- 20 - Bore Diameter 1 5/8"
- 21 - Bore Diameter 1 3/4"
- 22 - Bore Diameter 1 7/8"
- 23 - Bore Diameter 2"

Notes:

Standard mounting thread is 5/8-18 UNF-2A.

Ordering Procedure

Example: Speed indicating system for a variable speed motor, 0 - 1750 RPM, 1" shaft diameter, panel-mount display within 10 ft., min. motor speed is 175 RPM.

1. Select Model No. **T79850 - 103 - 1215**
 30 PPR, std. basic model
 Taper-lock, sealed bearing 1" bore dia.

2. Select a speed sensor such as P/N 70085-1010-001
3. Select a cable assembly, P/N CA79860-01-00, to complement (2).
4. Select tachometer to meet application needs.

Sensor Mounting Brackets

Several types of brackets are available to facilitate the mounting of AI-Tek speed sensors. Threaded brackets for 3/8-24, 5/8-18 and 3/4-20 threads are generally used with passive sensors with one locknut. Active, zero-velocity sensors and passive, chisel-point sensors that require specific alignment should be used with unthreaded brackets and two locknuts.

Bracket material is non-magnetic, 303 stainless steel; locknuts are also non-magnetic stainless steel or plated brass.

Sensors and brackets should be attached to a frame free of excessive vibration to prevent spurious indications when the gear is stopped or turning at very slow speeds. Refer to sensor specifications for proper air gap and alignment with gear (target) rotation.



Caution: Too small an air gap, especially with excessive run-out, may cause the gear to strike the sensor and make it inoperative.

Threaded Brackets		
Thread Size	Bracket Part No.	One Turn Advances
3/8-24 UNF-2B	646-310-0006	.042"
5/8-18 UNF-2B	646-310-0007	.056"
3/4-20 UNEF-2B	646-310-0008	.050"

Net Weight: 4 oz. max.

Unthreaded Brackets		
Thread Size Of Sensor	Hole Diameter	Bracket Part No.
3/8-24 UNF-2A	.390"	646-140-0009
5/8-18 UNF-2A	.640"	646-140-0010
3/4-20 UNEF-2A	.765"	646-140-0015

Net Weight: 2 oz. max.

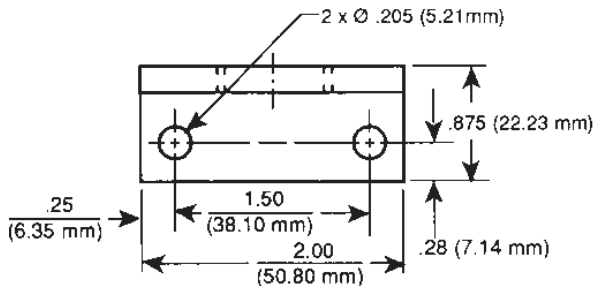

Threaded Bracket

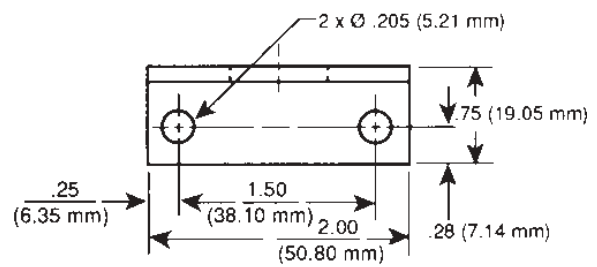

Unthreaded Bracket

Dimensions in inches and (mm).

PART NUMBER INDEX

Part Number Page

Tachometers

T77130 (TachPak 1).....	7
T77310 (Tachtrol 3).....	13
T77410(STACKTACH).....	4
T77430 (Tach Pak 3).....	10

Enclosures

.....	16
T79850 (Transducers).....	54

Passive Sensors

70084-1713-111.....	27
70085-1010-001.....	24
70085-1010-002.....	24
70085-1010-003.....	24
70085-1010-004.....	25
70085-1010-005.....	34
70085-1010-007.....	29
70085-1010-018.....	24
70085-1010-024.....	32
70085-1010-026.....	24
70085-1010-028.....	25
70085-1010-037.....	33
70085-1010-041.....	30
70085-1010-056.....	29
70085-1010-078.....	26
70085-1010-081.....	34
70085-1010-086.....	29
70085-1010-118.....	24
70085-1010-131.....	26
70085-1010-137.....	26
70085-1010-174.....	30
70085-1010-175.....	24
70085-1010-182.....	33
70085-1010-214.....	26
70085-1010-220.....	27
70085-1010-227.....	32
70085-1010-289.....	33
70085-1010-299.....	33
70085-1010-314.....	31
70085-1010-327.....	34
70085-1010-328.....	34

Part Number Page

70085-1010-329.....	34
70085-1010-330.....	34
70085-1010-355.....	29
70085-1010-403.....	35
70085-1010-404.....	35
70085-1010-405.....	35
70085-1010-406.....	35
70085-1010-408.....	24
70085-1010-411.....	34
70085-1010-412.....	34
70085-1010-413.....	34
70085-1010-414.....	34
70085-1010-415.....	35
70085-1010-416.....	35
70085-1010-417.....	35
70085-1010-420.....	35
70085-1010-421.....	28
70085-1010-424.....	28
70085-1010-425.....	28
70085-1010-428.....	30
70085-1010-458.....	30
70085-1010-469.....	25
70085-1010-472.....	32

70085-8080-001.....	31
70085-8080-003.....	27
70085-8080-004.....	31
Side Look Sensors.....	36-37

Hall Effect Sensors

H1320-XXX.....	44-45
H1512-XXX.....	40-43
H1522-XXX.....	40-43
H1612-XXX.....	40-43
H1622-XXX.....	40-43
Bi-Directional.....	46-49

Connectors and Cable Assemblies

CA79860-01-XX.....	50
--------------------	----

Gears

G79870-202-XXXX.....	52
----------------------	----

Brackets

646-XXX-XXXX.....	56
-------------------	----

AI-TEK Instruments, LLC.

152 Knotter Drive
P.O. Box 748
Cheshire, CT USA 06410-0748
www.aitekinstruments.com



Phone: 1-800-271-6000

13000-L 2/04
Printed in U.S.A.