

# ***DS EUROPE***

*TRANSDUCERS AND INDUSTRIAL ELECTRONIC EQUIPMENT*

---

**MICROPROCESSOR BASED**

**SIGNAL CONDITIONER**

***AN-401* SERIES**



***TECHNICAL MANUAL***

---

**Notice:** The information in this manual is subject to change without notice. DS Europe shall not be liable for technical or editorial errors or omissions contained herein, nor for incidental or consequential damages resulting from the furnishing, performance, or use of this material. This manual contains information

protected by copyright. No part of this manual may be photocopied, or reproduced in any form, or translated without prior written consent from DS Europe.

## FOREWORD

1. This manual is integral part of the shipment and it is supplied with the Product even if not listed in the invoice.

This manual can also be sent during purchase negotiation on Buyer's request provided that the Buyer states end application of the Product.

Except as expressly request by the Buyer, only one copy of this manual may be attached to shipments consisting of more than one unit of the Product.

2. The Products, which are the subjects of this manual, are designed and manufactured for general use; therefore, being not possible to specify limits of use for all applications, the Buyer shall introduce safety measures in order to avoid personal injuries, damages to property or damages due to plants stoppage, etc.

In case of use that can cause risk of damages, the Buyer shall immediately advise the Supplier in order that it can suggest safety solutions or can decide to reject the order and not to deliver the Product.

3. AN401 series of instruments are not certified instruments; it is Buyer's responsibility to check instrument suitability to the requirements of the specific application.

4. AN401 series of instruments, even when connected to transducers or other equipment, are only parts of more complex systems and plants; they are sold in thousands per year, for the most different applications which shall meet as many different norms that are not always known to the Supplier.

For these reasons, DS Europe is obliged to disclaim all responsibility concerning the use of the instrument; however, a list of the most elementary and basic precautions for the correct use of the instrument is given in this manual.

Besides, the need of a complete and specific insurance policy is highlighted, especially when systems and machinery are to be installed in Countries like United States or Canada.

5. AN401 series of instruments are designed and manufactured by DS Europe conforming to the highest quality standards; the instruments are rugged and designed to the highest possible safety and reliability: limitations and precautions listed in this manual are aimed to draw Buyer's attention to the importance of avoiding damages.

6. During manufacturing process, AN401 series of instruments are submitted to several intermediate tests and to a final test including performance test of all functions.

Electrical, temperature and mechanical sampling tests are periodically carried out to check conformity of manufactured items to Product specifications.

**For the overmentioned it is thereby certified that the delivered Product is completely operating.**

**DS EUROPE S.r.l.**

Via F. Russoli, 6

20143 MILAN - ITALY

tel. +39 02 8910142

fax +39 02 89124848 / 8910145

E-mail:

- [dseurope@tin.it](mailto:dseurope@tin.it)

- [dseuftec@tin.it](mailto:dseuftec@tin.it)
- [dseufcom@tin.it](mailto:dseufcom@tin.it)

## CE Declaration of Conformity

**Applied Council's directives:** 89/336/CEE modified by directives 92/31/CEE, 93/68/CEE

**Conformity to Standards:** EMC:  
EN 50081-2: 1994 - Emissions, General Norm  
EN 55011  
EN 50082-2: 1995 - Susceptibility, General Norm  
ENV 50140  
ENV 50141  
EN 61000-4-4  
EN 61000-4-2  
EN 61000-4-8  
ENV 50204

**Manufacturer:** DS Europe srl

**Address:** via F. Russoli, 6 Milan (Italy)

**Equipment type:** Indicator Conditioner

**Model:** AN401 series

**Year of registered mark:** 1998

The equipment has been tested in the typical installation configuration, as described by the instruction manual of the Product.

DS Europe srl certify that the above defined equipment meets the requirements of above mentioned EMC directives.

Milan, June 12th 1998

DS Europe srl  
Technical Dept.

***SIGNAL CONDITIONER  
AN-401 SERIES***

***HARDWARE AND SOFTWARE  
TECHNICAL MANUAL***

# CONTENTS

<b>1. GENERAL OVERVIEW.....</b>	<b>11</b>
1.1. INTRODUCTION.....	11
1.2. ORDER INFORMATION.....	11
1.3. BLOCK DIAGRAM .....	12
1.4. COMPONENT LAYOUT .....	13
<b>2. TECHNICAL CHARACTERISTICS.....</b>	<b>14</b>
2.1. POWER SUPPLY.....	14
2.1.1. AN401-12.....	14
2.1.2. AN401-24.....	14
2.2. TRANSDUCER POWER SUPPLY.....	14
2.2.1. AN401-12.....	14
2.2.2. AN401-24.....	14
2.3. ANALOG INPUT SIGNALS.....	15
2.3.1. DIFFERENTIAL INPUT .....	15
2.3.2. SINGLE ENDED INPUT.....	15
2.4. RESOLUTION.....	15
2.5. ANALOG INPUT ADJUSTMENT.....	15
2.6. DISPLAY.....	15
2.7. LEDs.....	16
2.8. FRONT PANEL PUSHBUTTONS.....	16
2.9. BANDWIDTH.....	16
2.10. SERIAL COMMUNICATION .....	16
2.11. ANALOG OUTPUT.....	17
2.12. EXTERNAL COMMANDS.....	17
2.13. LIMIT LEVELS.....	17
OVERALL DIMENSIONS.....	17
<b>3. INSTRUMENT SETUP.....</b>	<b>19</b>
3.1. PRELIMINARY RECOMMENDATIONS.....	19
3.2. ELECTRICAL CONNECTIONS TO REAR PANEL .....	19
3.2.1. No. 1 TERMINAL.....	20
3.2.2. No. 2 TERMINAL.....	20
3.2.3. No. 3 TERMINAL.....	20
3.2.4. No. 4 TERMINAL.....	20
3.2.5. No. 5 TERMINAL.....	20
3.2.6. AIN TERMINAL.....	20
3.2.7. COMMON TERMINALS .....	20
3.2.8. +VDC TERMINAL .....	21
3.2.9. EARTH TERMINAL.....	21
3.2.10. AOUT TERMINAL.....	21
3.2.11. REL 4 TERMINALS.....	21

3.2.12.	REL 3 TERMINALS.....	21
3.2.13.	REL 2 TERMINALS.....	21
3.2.14.	REL 1 TERMINALS.....	21
3.2.15.	KEY 4 TERMINAL.....	21
3.2.16.	KEY 3 TERMINAL.....	22
3.2.17.	KEY 2 TERMINAL.....	22
3.2.18.	KEY 1 TERMINAL.....	22
<b>3.3.</b>	<b>JUMPERS CONFIGURATION SETUP .....</b>	<b>22</b>
3.3.1.	INSTRUMENT OPENING.....	22
3.3.2.	JUMPERS FOR RELAY OUTPUT CONTACTS.....	23
3.3.3.	SELECTION OF RELAY OUTPUT CONTACT .....	23
3.3.4.	JUMPERS FOR CALIBRATION SELECTION .....	24
3.3.5.	JUMPER FOR INPUT SELECTION .....	25
<b>3.4.</b>	<b>POWER SUPPLY WIRING .....</b>	<b>26</b>
<b>3.5.</b>	<b>EARTHING.....</b>	<b>26</b>
<b>3.6.</b>	<b>DIFFERENTIAL INPUT WIRING .....</b>	<b>27</b>
<b>3.7.</b>	<b>SINGLE ENDED INPUT WIRING.....</b>	<b>28</b>
3.7.1.	A5 ( $\pm 5V$ ) AMPLIFIED TRANSDUCERS WIRING .....	28
3.7.2.	A10 ( $\pm 10V$ ) AMPLIFIED TRANSDUCERS WIRING.....	29
3.7.3.	SERVOINCLINOMETER ES200 OR OTHER $\pm 15 V$ TRANSDUCER WIRING.....	30
<b>3.8.</b>	<b>DIGITAL INPUT WIRING.....</b>	<b>31</b>
3.8.1.	DIGITAL INPUT FROM EXTERNAL MECHANICAL CONTACTS.....	31
3.8.2.	DIGITAL INPUT FROM LOGIC SIGNALS .....	32
<b>3.9.</b>	<b>RELAY CONTACTS WIRING.....</b>	<b>32</b>
<b>3.10.</b>	<b>SERIAL PORT WIRING.....</b>	<b>32</b>
3.10.1.	RS-232 POINT-TO-POINT WIRING.....	32
3.10.2.	RS485 BIDIRECTIONAL MULTIDROP WIRING.....	33
3.10.3.	GENERAL CONSIDERATIONS ON SERIAL LINES.....	33
<b>4.</b>	<b>INSTRUMENT CALIBRATION PROCEDURES.....</b>	<b>35</b>
<b>4.1.</b>	<b>INSTRUMENT POWER ON.....</b>	<b>35</b>
<b>4.2.</b>	<b>CALIBRATION MENU .....</b>	<b>37</b>
	ANALOG INPUT ADJUSTMENT (CAL).....	38
4.2.2.	MINIMUM READING VALUE (LO).....	40
4.2.3.	MAXIMUM VALUE (HI) .....	40
4.2.4.	MAXIMUM VALUE (HICAL).....	40
4.2.5.	TARE.....	41
4.2.6.	CALIBRATION HINTS .....	41
<b>4.3.</b>	<b>CUSTOMIZATION MENU.....</b>	<b>48</b>
4.3.1.	CONVERSION TO MECHANICAL UNITS AND RESOLUTION.....	50
4.3.2.	LIMIT LEVELS AND HYSTERESIS .....	51
4.3.3.	FILTERING.....	52
4.3.4.	SERIAL TRANSMISSION RATE .....	52
4.3.5.	SERVOINCLINOMETER CONVERSION .....	53
4.3.6.	CHANGING LIMIT LEVELS IN MEASURE MODE .....	53
4.3.7.	DISPLAY MODE.....	54
4.3.8.	TARE SETTING.....	55
4.3.9.	INSTRUMENT IDENTIFIER.....	55

<b>4.4.</b>	<b>CLOCK MENU.....</b>	<b>55</b>
<b>4.5.</b>	<b>EEPROM MEMORY .....</b>	<b>58</b>
<b>5.</b>	<b>MEASURING FUNCTIONS OF AN401 .....</b>	<b>59</b>
<b>5.1.</b>	<b>NET.....</b>	<b>59</b>
<b>5.2.</b>	<b>GROSS.....</b>	<b>59</b>
<b>5.3.</b>	<b>PIECE-COUNTER.....</b>	<b>59</b>
<b>5.4.</b>	<b>ERROR.....</b>	<b>59</b>
<b>5.5.</b>	<b>PEAK.....</b>	<b>60</b>
<b>5.6.</b>	<b>HOLD .....</b>	<b>60</b>
<b>5.7.</b>	<b>PRINT.....</b>	<b>60</b>
<b>6.</b>	<b>SERIAL COMMUNICATION PROTOCOL.....</b>	<b>62</b>
<b>6.1.</b>	<b>PROTOCOL FORMAT.....</b>	<b>62</b>
6.1.1.	COMMAND MESSAGE FORMAT .....	62
6.1.2.	CONFIGURATION MESSAGE FORMAT .....	63
<b>6.2.</b>	<b>AVAILABLE COMMANDS .....</b>	<b>65</b>
6.2.1.	“C” COMMAND .....	65
6.2.2.	“G” COMMAND.....	65
6.2.3.	“H” COMMAND.....	65
6.2.4.	“INIT” COMMAND.....	67
6.2.5.	“K” COMMAND.....	67
6.2.6.	“L” COMMAND .....	68
6.2.7.	“P” COMMAND .....	68
6.2.8.	“R” COMMAND.....	69
6.2.9.	“V” COMMAND.....	69
6.2.10.	“Z” COMMAND .....	69
<b>6.3.</b>	<b>CUSTOMIZATION PARAMETERS.....</b>	<b>71</b>
<b>6.4.</b>	<b>RESPONSES FROM AN401 .....</b>	<b>72</b>
<b>7.</b>	<b>CE MARKING .....</b>	<b>73</b>
<b>7.1.</b>	<b>ELECTROMAGNETIC INTERFERENCE PROTECTION .....</b>	<b>73</b>
<b>7.2.</b>	<b>TEST LABORATORY AND TEST LIST .....</b>	<b>75</b>
<b>7.3.</b>	<b>TEST RESULTS AND CONFIDENTIAL INFORMATION.....</b>	<b>75</b>
<b>8.</b>	<b>TERMS OF SALE .....</b>	<b>76</b>
<b>8.1.</b>	<b>LIMITED WARRANTY .....</b>	<b>76</b>
<b>8.2.</b>	<b>LIABILITY FOR DAMAGES .....</b>	<b>76</b>

## 1. GENERAL OVERVIEW

---

### 1.1. INTRODUCTION

The panel mounting instrument described herein is part of a new family of microprocessor based products designed and manufactured by DS Europe.

This general purpose instrument can be connected to the signals provided by any DS Europe transducers as:

- pressure transducers
- load cells
- position transducers
- inclinometers; in this case, the instrument can display the results directly in degrees
- torque meters
- radial load cells

The instrument can also be connected to standard voltage signals.

The instrument includes many standard functions, e.g. readings in mechanical units, piece-counter, linearization and other functions as described in this manual or which will be implemented later according to Customer's requests.

### 1.2. ORDER INFORMATION

The AN-401 family of instruments is coded as follows:

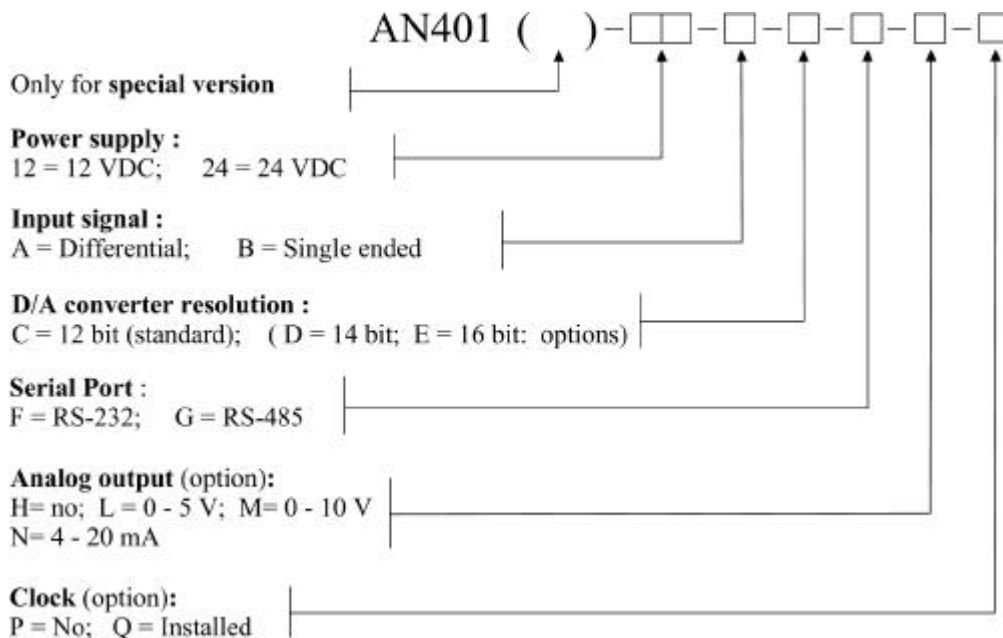

**Fig. 1** Definition of Model Coded Variants

### 1.3. BLOCK DIAGRAM

The block diagram of AN401 is shown in fig. 2: the microprocessor is in the center of the picture and all the peripherals are around it.

The microprocessor is a RISC type, 16-bit, 20 MHz clock rate; some peripherals are embedded into the microprocessor to supervise power supply (POWER-ON), to avoid alting of executing program (WATCH-DOG) and to RESET.

An EEPROM technology memory has been selected to store instrument parameters in order to ensures data retention, without battery or other means, when power is switched off.

A Flash technology memory has been selected as program memory in order to easily update the software loaded into the instrument.

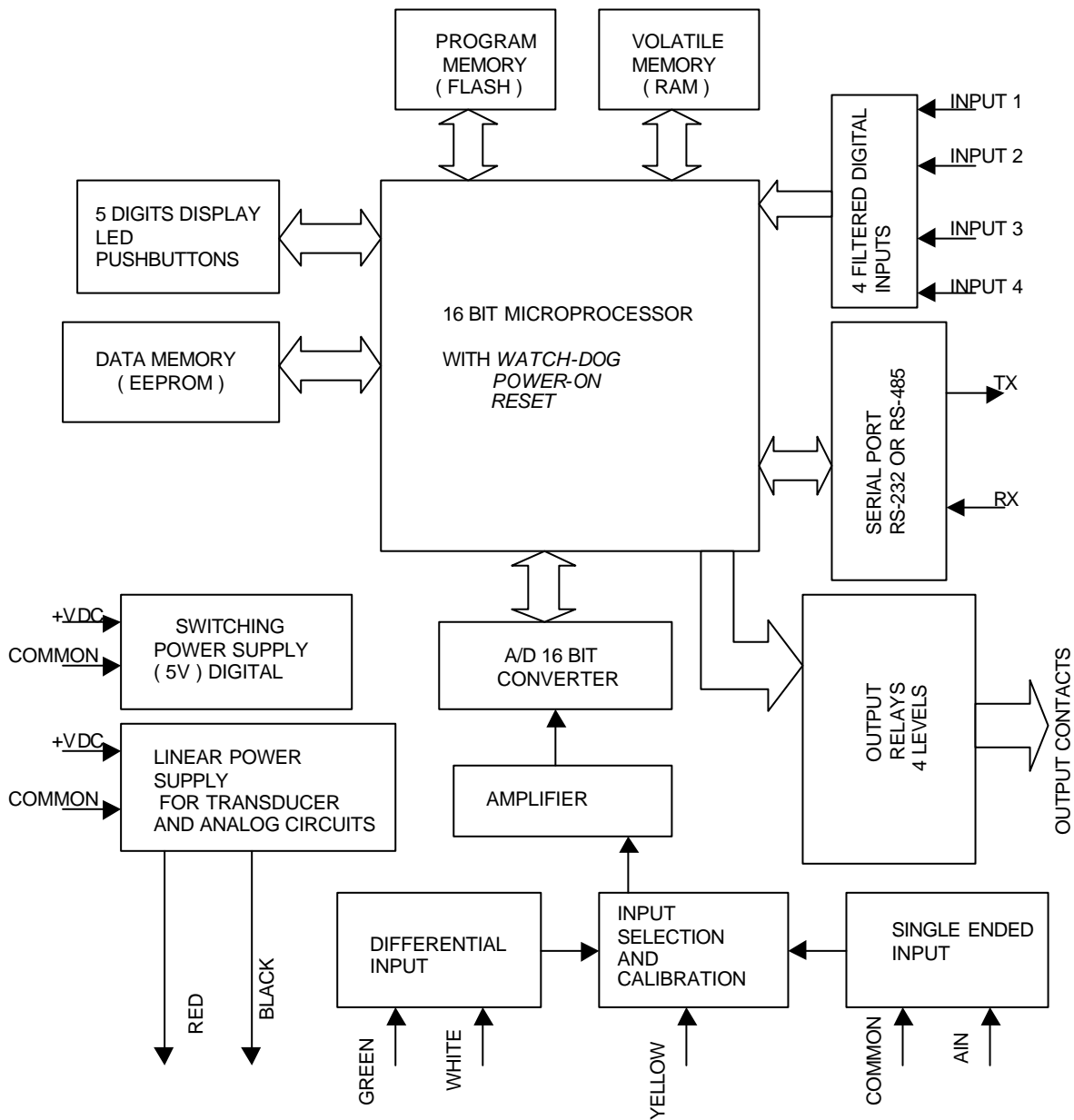

Fig. 2 AN401 Block Diagram

### 1.4. COMPONENT LAYOUT

The layout of electronic components on the printed circuit board is shown in fig. 3 where the position of some jumpers is highlighted: these jumpers are used to change hardware configuration of AN401 in order to suit the most different applications.

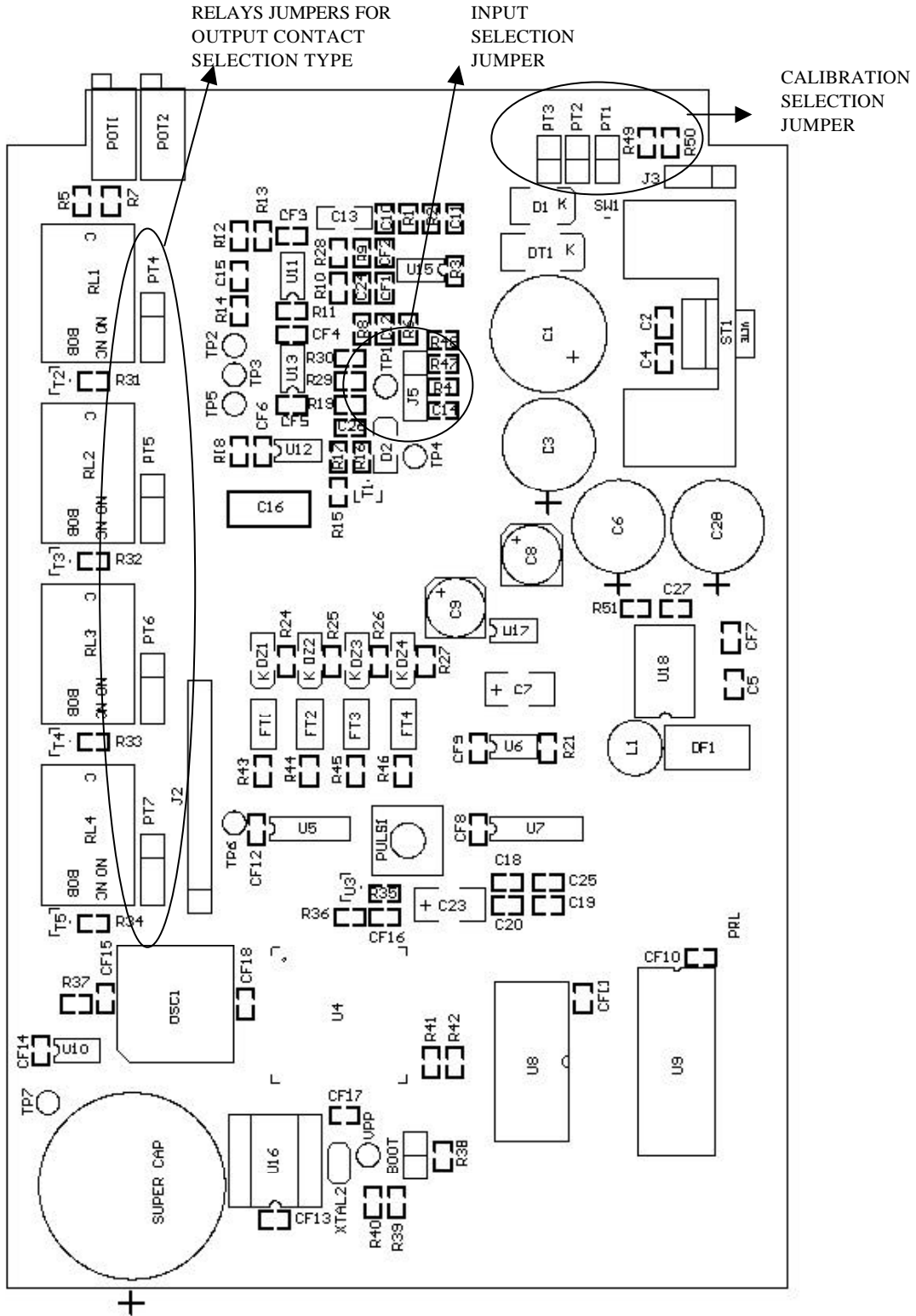

Fig. 3 Components Layout on PCB

## 2. TECHNICAL CHARACTERISTICS

---

### 2.1. POWER SUPPLY

The instrument, according to the selected variant, can be powered by different supply voltages. Two variants are available, as follows.

#### 2.1.1. AN401-12

The nominal voltage is **12 VDC±20%**, i.e. the instrument is fully operating when the power supply voltage is between **9.6** and **14.4 VDC**.

Should power supply be lower than **9.6 VDC**, internal power supply regulation is lost.

The maximum allowable voltage is **28 VDC**.

Power supply voltage higher than **14.4 VDC** causes longer “warm-up” time.

#### 2.1.2. AN401-24

The nominal voltage of this variant is **24 VDC±20%**, i.e. the instrument is full operating when the power supply voltage is between **19.2** and **28.8 VDC**.

The minimum voltage without losing internal regulation is **15.5 VDC**, while the maximum allowable voltage is **32 VDC**.

### 2.2. TRANSDUCER POWER SUPPLY

Both variants of the instrument can provide supply voltage to non amplified strain-gauge bridge transducers.

The minimum resistance of the bridge shall not be less than 120 ohm.

The voltage provided to the transducer is as follows:

#### 2.2.1. AN401-12

The voltage provided to the transducer is 8 VDC.

Should the transducer require a lower voltage, connect two series resistors in order to obtain the required voltage.

Example: to supply a transducer of BC 300 series, which requires 5 VDC maximum, connect two 160 ohm series resistors.

#### 2.2.2. AN401-24

The voltage provided to the transducer is 12 VDC.

See example of paragraph 2.2.1 to lower the voltage provided to the transducer, with two 300 ohm series resistors.

Model AN401-24 can also supply DS Europe amplified transducers with A5 output variant ( $\pm 5$  V) and all the conditioning boards EL 500 series, A5 output variant.

Generally, Model AN401-24 can supply any system requiring 12 VDC power supply, e.g. it is possible to connect a load cells summing unit mod. EL574-12 or a pressure transducer mod. LP655.

**Note applicable to both models:** current consumption of transducers shall not exceed **120 mA**.

This value is limited by the maximum allowable dissipation of the internal regulator.

### 2.3. ANALOG INPUT SIGNALS

The analog input signal to the AN401 shall be a **voltage mode signal**; current mode signals cannot be directly connected to the instrument.

Two input stages are provided: one stage is suitable for differential signals, while the other stage is suitable for single ended signals referred to ground; in this case, the polarity of the signal vs. ground can be either positive or negative.

#### 2.3.1. DIFFERENTIAL INPUT

This input provides maximum flexibility and good stability even at high gain.

The following full scale ranges are available:

- $\pm 5$  mV
- $\pm 10$  mV
- $\pm 20$  mV
- $\pm 40$  mV
- $\pm 80$  mV

#### 2.3.2. SINGLE ENDED INPUT

Available full scale ranges are:

- $\pm 1$  V
- $\pm 2.5$  V
- $\pm 5$  V
- $\pm 10$  V

Typical input impedance of both stages is 1 Megaohm.

### 2.4. RESOLUTION

Analog to digital conversion of the input signal is performed by means of a 16-bit A/D converter providing 65,535 conversion points.

Available conversion points shall be allocated considering conversion to mechanical units, required calibration and the range of input signal.

For further details about allocation of conversion points, see chapter *4-Instrument Calibration Procedures* of this manual.

### 2.5. ANALOG INPUT ADJUSTMENT

In the rear panel of the instrument, there are two holes marked “ZERO” and “GAIN” (see fig. 4); these holes allow easy access to zero and gain trimmers to adjust input stage of AN401.

The position of these trimmers is protected in order to avoid unwanted or accidental adjustment.

It is recommended to not stress the trimmers using the screwdriver.

See chapter 4 for trimmer adjustment.

### 2.6. DISPLAY

The display consists of 5 digits , 7 segments LED type indicator.

An additional LED in front of the most significant digit allows to display minus sign without wasting any digit; therefore any value in the range  $\pm 99999$  can be displayed.

The display of the decimal point is software controlled by AN401 and is User defined.

According to the calibration of the instrument together with the transducer, the AN401 displays the measured value in the required mechanical units.

Calibration also determines the resolution of the measured signal, i.e. the smallest value of the input signal which can be displayed in mechanical units.

### 2.7. *LEDs*

On the front panel of the instrument there are four LEDs marked 1 thru 4; functions of these LEDs are in accordance to the selected mode of operations of the instrument.

For instance, in net weight mode of operations, LED 1 is ON when the measured value reaches the value defined for limit level no. 1 and, as a consequence, relay no. 1 is activated.

Alternatively, a blinking LED shows the selected measurement function, i.e. NET, GROSS, PIECE-COUNTER or ERROR.



### 2.8. *FRONT PANEL PUSHBUTTONS*

Below instrument display there are four pushbuttons protected by a film strengthened with polypropylene.

The main functions of these pushbuttons are as follows:

- $\theta$  (*down*); it allows: to move one level down in the configuration menus of AN401; or to move to next measuring mode; or to decrease the value of a parameter.
- $\pi$  (*up*); it allows: to move one level up in the configuration menus of AN401; or to activate printing through the serial printer; or to increase the value of a parameter.
- E (*Enter*); it allows: to confirm data entry by the User and to save them into the instrument; or to save the value of the sample in PIECE-COUNTER mode of operations.
- C (*ESC*); it allows: to escape from any menu without saving changed parameters, if any; or to clear the reading when in measuring mode.

The above pushbuttons may have other functions according to the selected mode of operations and to the specific context where they are used (see chapters 4 and 5).

To avoid damages, it is recommended to gently press pushbuttons and to not use sharpened tools, like screwdrivers and similar tools, which can damage the instrument.

### 2.9. *BANDWIDTH*

The bandwidth of the instrument is 25 - 30 Hz approximately when no digital filter is activated.

### 2.10. *SERIAL COMMUNICATION*

AN401 instrument can be connected to a remote computer, for instrument setting and/or data display, or connected to a serial printer.

For these purposes, the instrument is provided with a serial port which can be either an RS-232 serial port (standard version) or an RS-485 serial port (option).

Data transmission rate is User selectable between 600 and 57,600 baud.

As detailed in chapter 6, a simple protocol allows transfer of data from the instrument and setting of instrument parameters.

### 2.11. ANALOG OUTPUT

Optionally, an analog output board can be installed into the instrument; the analog output is proportional to the displayed value and can be used to implement a simple closed loop system.

The analog output is obtained by means of a D/A converter, the resolution of which is 8 to 16 bits (12-bit D/A converter for standard version).

The analog output is available as voltage or current output with the following full scale ranges:

- $\pm 5$  V (5 mA maximum load)
- $\pm 10$  V (5 mA maximum load) **only with AN401-24**
- 0-20 mA
- 4-20 mA
- 4-20 mA (with 12 mA corresponding to physical zero)

The voltage output should be connected to a high impedance load for a correct use of the instrument.

### 2.12. EXTERNAL COMMANDS

TTL inputs are used to synchronize instrument functions to external equipment part of User's system.

According to the software version loaded into AN401, different functions can be assigned to these inputs, e.g. printing, net weight function, peak holding, etc.

These inputs are active low and can also be activated by closure to ground of switches or relays contacts (see paragraph 3.8).

Inputs are provided with software filter for debouncing and noise rejection.

### 2.13. LIMIT LEVELS

Four limit levels are available: each level can be set in the range  $\pm 100\%$  of full scale value in mechanical units.

Four internal relays are associated to limit levels: each relay is activated when the relevant set point is reached by the input signal.

The output contact of each relay can be selected as normally open (NO) or normally closed (NC); moreover, a hysteresis around each level can be software defined in the range 0-50 mechanical units.

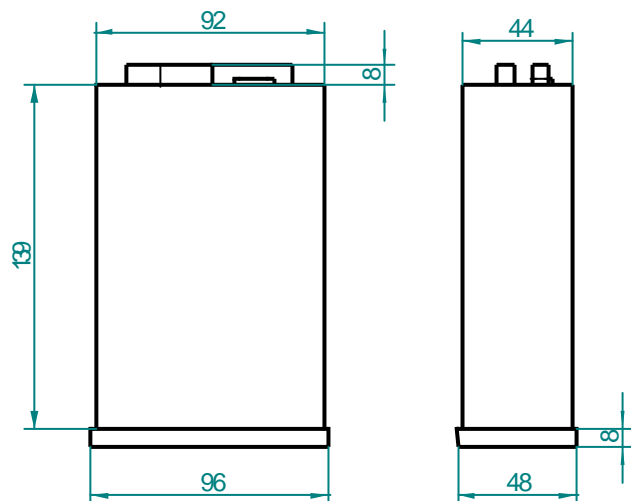

### 2.14. OVERALL DIMENSIONS

DIN standard 96x48 mm; depth: 147 mm.

Panel cut out: 92x44 mm.

Dimensions in mm.

### 3. INSTRUMENT SETUP

#### 3.1. PRELIMINARY RECOMMENDATIONS

Electrical connections to the instrument shall be in accordance with all rules and standards in use concerning safety and accident prevention.

Specific cares shall be taken to avoid that electrical connections to the instrument may propagate electrical interference that could be present at the environment where the instrument is installed.

It is also recommended to have a good knowledge of the instrument and its functions before final setup: it is suggested to connect the transducer and to calibrate the system preliminarily at laboratory.

#### 3.2. ELECTRICAL CONNECTIONS TO REAR PANEL

**Fig. 4** shows the rear panel of the instrument.

Rear terminals are screw type terminals, connector for serial port is DB-9 standard connector used for serial connections to PC.

In the low right part of the panel, there are two holes which allow easy access to **ZERO** and **GAIN** trimmers.

**Note:** to avoid damages to the instrument, it is recommended to avoid direct mechanical stress to the terminals or indirect stress due to connecting cables.

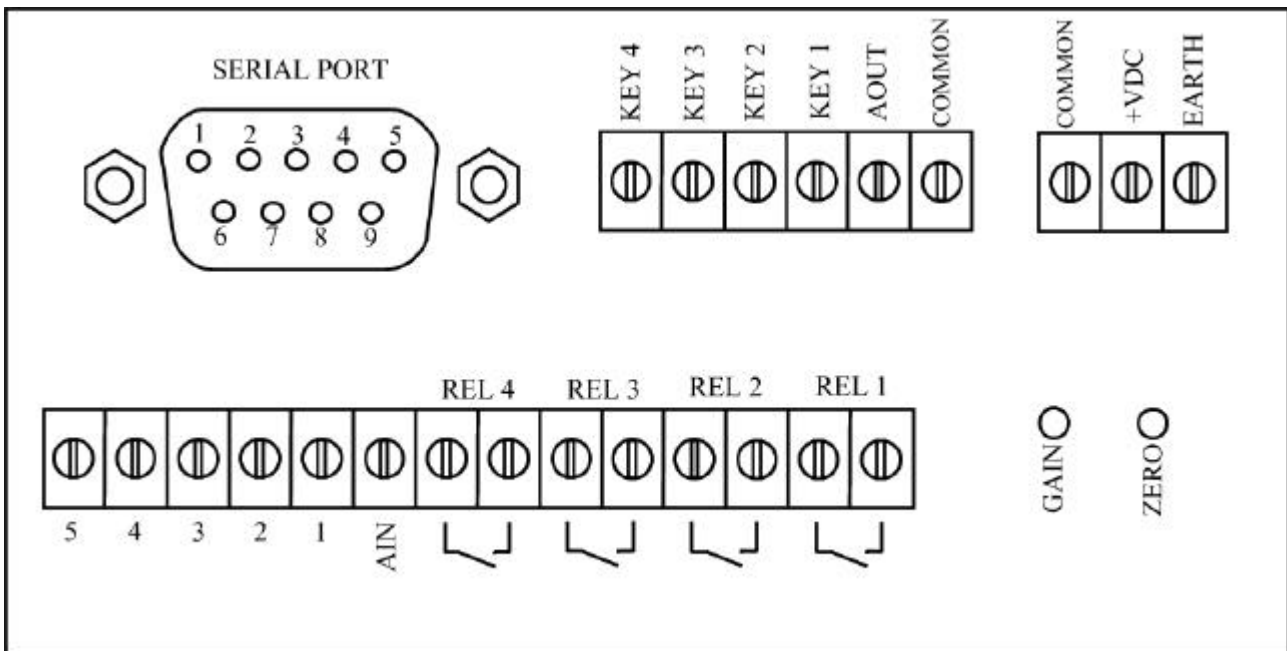

**Fig. 4** Rear Panel

**Table 1** hereafter gives a brief description of the functions of each terminal; a more detailed description is given in the following paragraphs.

TERMINAL	DESCRIPTION	DS Europe
1	ANALOG SIGNAL DIFFERENTIAL INPUT (+)	WHITE
2	ANALOG SIGNAL DIFFERENTIAL INPUT (-)	GREEN
3	CALIBRATION INPUT	YELLOW
4	POSITIVE POWER SUPPLY OUTPUT (+)	RED
5	NEGATIVE POWER SUPPLY OUTPUT (-)	BLACK
AIN	ANALOG SIGNAL INPUT (SINGLE ENDED)	
COMMON	TWO TERMINALS FOR RETURN SIGNALS, I.E.:	
COMMON	ANALOG, DIGITAL AND POWER SUPPLY GROUND	
+VDC	POWER SUPPLY INPUT (+12VDC / +24VDC)	
EARTH	EARTH TERMINAL	
AOUT	ANALOG OUTPUT	
REL4	LEVEL 4 OUTPUT CONTACTS	
REL4		
REL3	LEVEL 3 OUTPUT CONTACTS	
REL3		
REL2	LEVEL 2 OUTPUT CONTACTS	
REL2		
REL1	LEVEL 1 OUTPUT CONTACTS	
REL1		
KEY 1	DIGITAL INPUT No. 1	
KEY 2	DIGITAL INPUT No. 2	
KEY 3	DIGITAL INPUT No. 3	
KEY 4	DIGITAL INPUT No. 4	

### 3.2.1. No. 1 TERMINAL

Positive polarity input (+) from the transducer output signal.

For DS Europe load cells: white wire.

For input voltage range, see paragraph 2.3.1.

### 3.2.2. No. 2 TERMINAL

Negative polarity input (-) from the transducer output signal.

For DS Europe load cells: green wire.

For input voltage range, see paragraph 2.3.1.

### 3.2.3. No. 3 TERMINAL

Calibration input of the transducer.

For DS Europe load cells: yellow wire.

### 3.2.4. No. 4 TERMINAL

Positive power supply output (+) to the transducer.

For DS Europe load cells: red wire.

For output voltage range, see paragraph 2.1.1 or paragraph 2.1.2 according to the model.

### 3.2.5. No. 5 TERMINAL

Negative power supply output (-) to the transducer.

For DS Europe transducers: black wire.

### 3.2.6. AIN TERMINAL

Single ended input signal, ground referred.

For input voltage range, see paragraph 2.3.2.

### 3.2.7. COMMON TERMINALS

The following return signals shall be connected to these terminals: power supply ground, analog signal (AIN) ground, digital signals ground.

To make connections easier, two terminals are provided on the rear panel.

Also **PIN 5** of DB-9 connector (serial port) and **terminal No. 5** are internally connected to **COMMON**; for terminal No. 5 this is true on condition that no series resistor has been connected to lower transducer power supply.

### 3.2.8. +VDC TERMINAL

This is positive input of instrument power supply.

Power supply voltage is defined in paragraph 2.1.1 or paragraph 2.1.2 according to the model.

### 3.2.9. EARTH TERMINAL

Earth can be connected to this terminal.

It allows earthing of filtering devices internal to the instrument.

Earthing improves performances against electrical interference.

### 3.2.10. AOUT TERMINAL

When the relevant optional board is installed (see paragraph 2.11), this terminal provides an analog output (voltage or current) proportional to the displayed value.

### 3.2.11. REL 4 TERMINALS

An uncommitted relay contact is connected to these two terminals: the contact is activated when the value set for **LEVEL 4** is reached,

The contact can be selected as:

- NORMALLY OPEN (N.O.)
- NORMALLY CLOSED (N.C.)

by means of an internal jumper.

**Note:** the relay contact can withstand 1 A at 20 VDC maximum.

Select **NORMALLY OPEN** if the contact is required open until the displayed value is lower than the set value.

Select **NORMALLY CLOSED** if the contact is required closed until the displayed value is lower than the set value.

**Note:** the above description is also applicable to terminals described in paragraphs 3.2.12, 3.2.13 and 3.2.14 hereafter.

### 3.2.12. REL 3 TERMINALS

Relay contact relevant to **LEVEL 3** is connected to these terminals.

### 3.2.13. REL 2 TERMINALS

Relay contact relevant to **LEVEL 2** is connected to these terminals.

### 3.2.14. REL 1 TERMINALS

Relay contact relevant to **LEVEL 1** is connected to these terminals.

### 3.2.15. KEY 4 TERMINAL

Some functions of the instrument can be activated connecting a digital logic level to this input.

The following signals can be used:

- TTL/CMOS signals from remote devices
- External switch

The switch is active when closed to ground. An internal pull-up resistor to +5VDC is provided.

**Note:** the above description is also applicable to terminals described in paragraphs 3.2.16, 3.2.17 and 3.2.18 hereafter.

### 3.2.16. KEY 3 TERMINAL

Some functions of the instrument can be activated connecting a digital logic level to this input.

### 3.2.17. KEY 2 TERMINAL

Some functions of the instrument can be activated connecting a digital logic level to this input.

### 3.2.18. KEY 1 TERMINAL

Some functions of the instrument can be activated connecting a digital logic level to this input.

## 3.3. JUMPERS CONFIGURATION SETUP

Hardware configuration of AN401 can be changed at any time should a different transducer type or a different relay contact be required.

Changes can be carried out by the User, under his responsibility, to fit the instrument for specific application. **Fig. 3** shows a general overview of component layout on the printed circuit board.

### 3.3.1. INSTRUMENT OPENING

Instrument opening shall be carried out after removing power supply: this is to avoid damages or short circuit.

To open the instrument, simply unscrew the four (A) screws at the corners of the rear panel (see **fig. 5**), then gently slip electronics out of the chassis: please consider that display board and rear panel are vertically mounted on the main board.

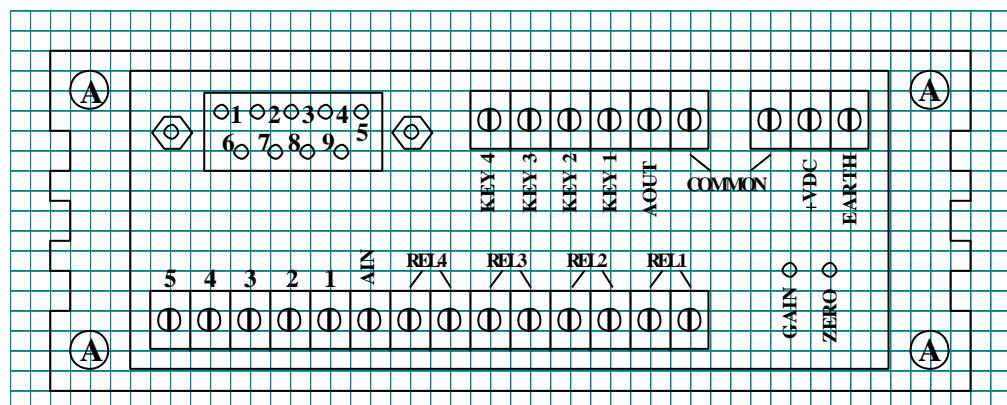
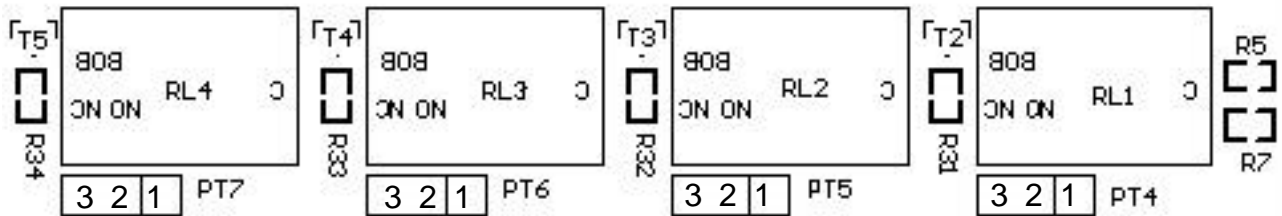

**Fig. 5** Rear View of AN401

Avoid mechanical stress to boards or to internal components.

Avoid introduction of external contaminants, e.g. water, oil, metallic blurs, tin pieces and any other contaminant which could damage the circuits.

If in doubt, send the instrument back to DS Europe detailing required operations.



**Fig. 6** Details of Relays Section

### 3.3.2. JUMPERS FOR RELAY OUTPUT CONTACTS

After electronics has been removed from chassis, locate the area detailed in fig. 6.

Near to the relays there are four jumpers, identified as PT 7, PT 6, PT 5, PT 4.

Each jumper is assigned to a relay and to a contact according to the following table:

JUMPER	RELAY	CONTACT
PT 7	RELAY No. 4	REL 4
PT 6	RELAY No. 3	REL 3
PT 5	RELAY No. 2	REL 2
PT 4	RELAY No. 1	REL 1

**Table 2** Jumpers, Relays and Contacts Assignment

### 3.3.3. SELECTION OF RELAY OUTPUT CONTACT

Tables 3, 4, 5, and 6 hereinafter show how the jumper is to be placed for each relay; the symbol · in the table identifies the pins to be short-circuited by the jumper to obtain the required function.

In table 3, for instance, if normally open (N.O.) contact is required, the jumper shall be placed between pins 1 and 2; if normally closed (N.C.) contact is required, the jumper shall be placed between pins 2 and 3.

The above example is also applicable to other jumpers (see tables 4, 5 and 6).

PT 7			OUTPUT CONTACT
3	2	1	
	·	·	NORMALLY OPEN
·	·		NORMALLY CLOSED

**Table 3** PT 7 Jumper for Relay No. 4

PT 6			OUTPUT CONTACT
3	2	1	
	.	.	NORMALLY OPEN
.	.		NORMALLY CLOSED

**Table 4** PT 6 Jumper for Relay No. 3

PT 5			OUTPUT CONTACT
3	2	1	
	.	.	NORMALLY OPEN
.	.		NORMALLY CLOSED

**Table 5** PT 5 Jumper for Relay No. 2

PT 4			OUTPUT CONTACT
3	2	1	
	.	.	NORMALLY OPEN
.	.		NORMALLY CLOSED

**Table 6** PT 4 Jumper for Relay No. 1

### 3.3.4. JUMPERS FOR CALIBRATION SELECTION

Should the transducer connected to AN401 be provided with an internal calibration circuit, as DS Europe transducers, this feature can be automatically activated by the instrument. PT 1, PT 2 and PT 3 jumpers allows to select three calibration modes suitable for all DS Europe series of transducers; fig. 7 details jumpers layout.

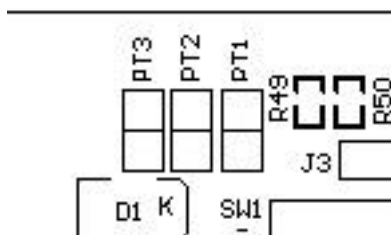

To properly place the jumper, also consult the manual of the transducer.

**Fig. 7** Details of Calibration Selection

AN401 allows to close automatically the calibration contact and therefore to check transducer calibration or to perform an automatic test on the functionality of the measuring chain whenever needed.

This function is directly carried out by the microprocessor which select calibration mode by means of a digital switch.

Also transducers without calibration circuit can be connected to the instrument: in this case, operating mode of AN401 is independent from PT 1, PT 2 and PT 3 setting.

JUMPER	CALIBRATION CIRCUIT CLOSING MODE
PT 1	Connect calibration wire (YELLOW) to GREEN
PT 2	Connect calibration wire (YELLOW) to WHITE
PT 3	Connect calibration wire (YELLOW) to GROUND

**Table 7** Calibration Jumper Selection (DS Europe wiring code)

For non-amplified load cells, calibration circuit consists of an internal resistor which, when connected in parallel to one arm of the strain gauge bridge, determines an unbalance corresponding to the mechanical value specified in test certificate of the transducer.

### 3.3.5. JUMPER FOR INPUT SELECTION

As mentioned in paragraph 2.3, it is possible to select the type of the input to be measured by AN401. The input signal type is selected by jumper J5 which is shown in fig. 8.

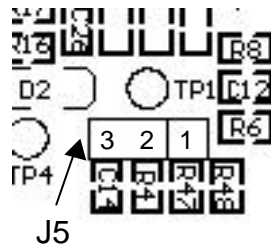

**Fig. 8** Details of Analog Input Selection

Table 8 shows the position of the jumper according to the required input type.

J5			INPUT SIGNAL
3	2	1	
	.	.	DIFFERENTIAL SIGNAL INPUT
.	.		SINGLE ENDED SIGNAL INPUT

**Table 8** Input Jumper

Example: should a non-amplified load cell be connected to the instrument, differential signal input shall be selected and the jumper shall be placed between pins 1 and 2.

### 3.4. POWER SUPPLY WIRING

Fig. 9 details wiring between the instrument and the power supply. Power supply negative polarity (*or return or common*) shall be connected to instrument COMMON terminal. This is also the common point for analog and digital signals. Power supply positive polarity (+VDC) shall be connected to instrument +VDC terminal.

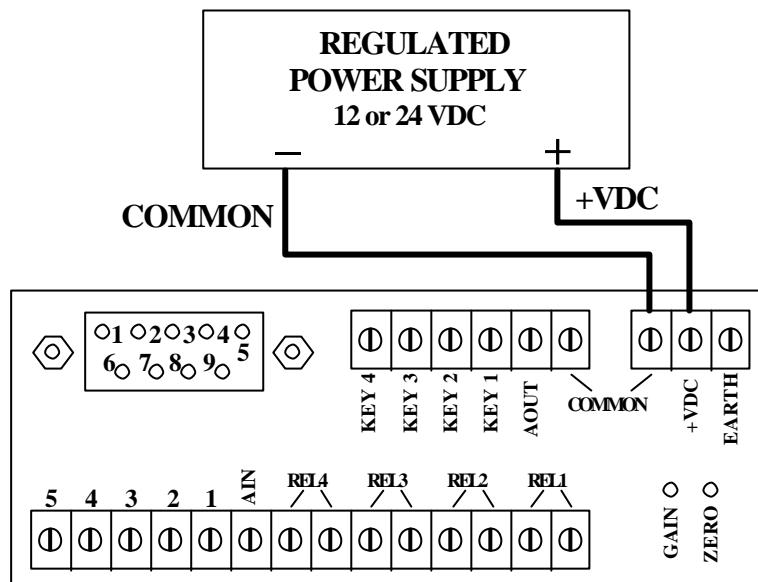

Reversing polarity must be avoided.

**Fig. 9** Power Supply Wiring

### 3.5. EARTHING

**Important notice:** AN401, the transducer and the system connected to them shall be earthed according to the rules in use in the Country where the system is installed. In case of conflict between these rules and this manual, the rules shall take precedence.

AN401 is provided with input filters (for power supply, analog and digital signals) and output filters (when the relevant option is installed).

The use of these filters may be required by the environment where the instrument is installed and allows improved protection in addition to interference and noise immunity of AN401 itself.

For good noise rejection of these filters, the instrument shall be connected to an earth which is free from other equipment noise.

Earthing of the instrument is shown in fig. 10. The shortest possible wire with a section according to rules shall be used and connected to EARTH terminal.

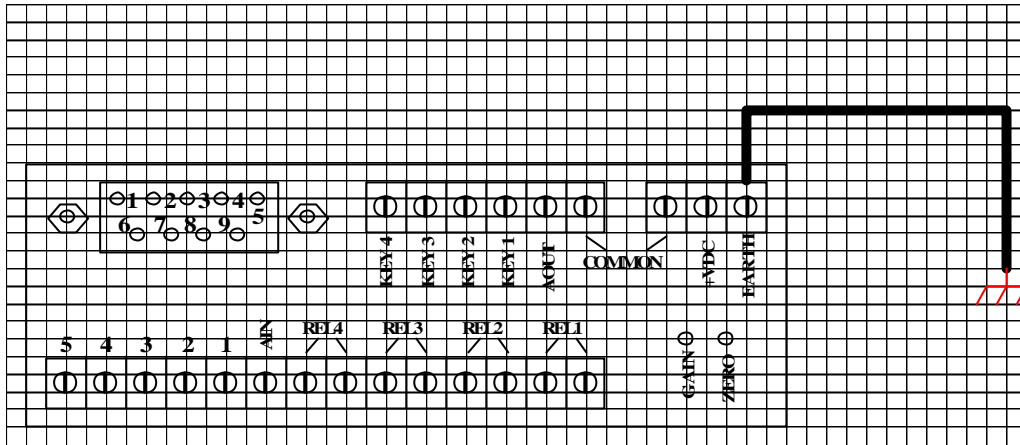

Fig. 10 Instrument Earthing

### 3.6. DIFFERENTIAL INPUT WIRING

Typical wiring diagram between differential input of AN401 and a transducer strain gauge bridge is shown in fig. 11.

Measuring ranges of differential input signal are listed in paragraph 2.3.1.

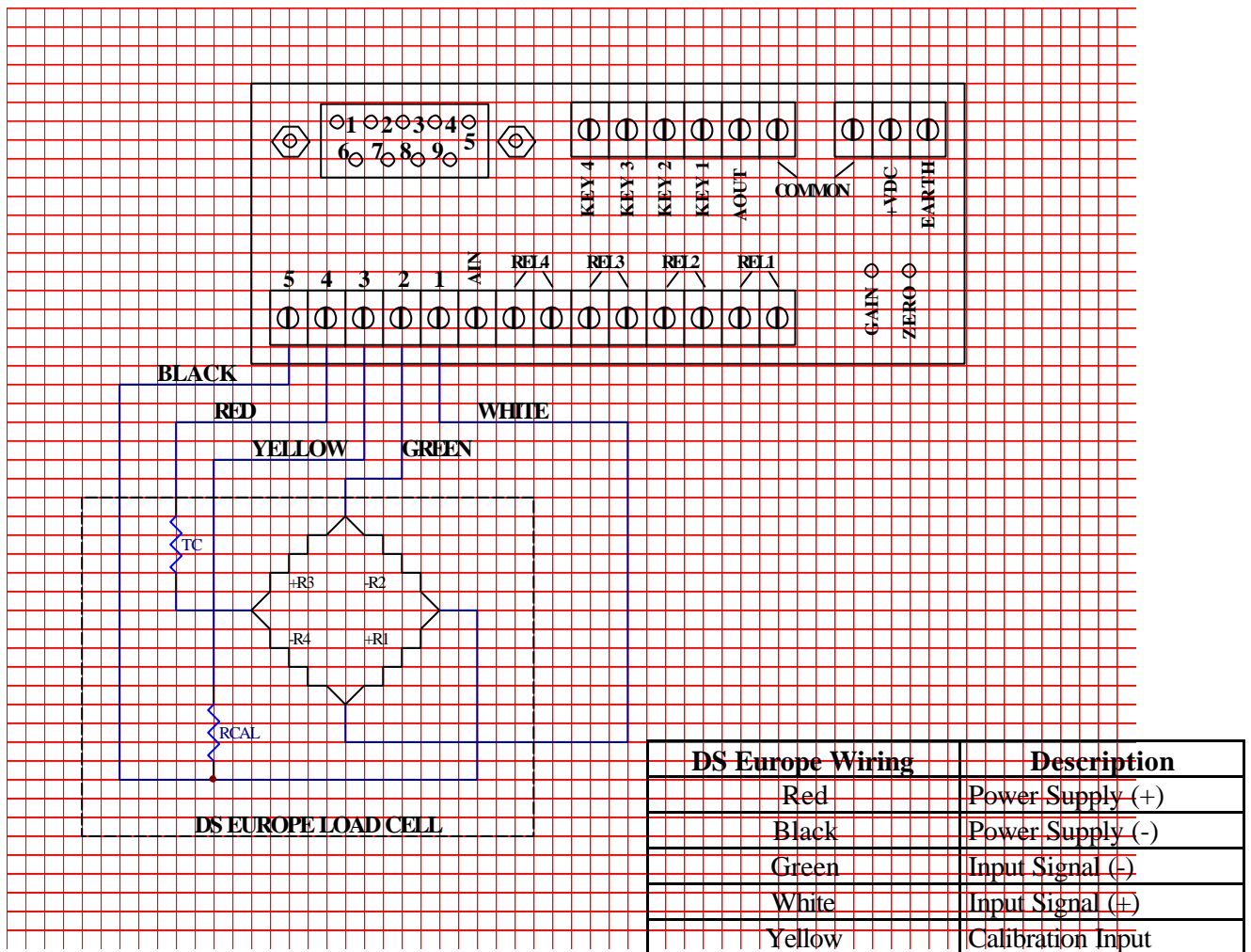

Fig. 11 Strain Gauge Connections to Differential Input

### 3.7. SINGLE ENDED INPUT WIRING

Generally, this input is used together with “amplified” transducers, i.e. transducers with internal electronics, signal amplifier and with high voltage output, e.g.  $\pm 5V$ , as described in paragraph 2.3.2. These transducers may require a voltage power supply equal to or different from the one provided by the instrument (see paragraphs 2.2.1 and 2.2.2). If the required voltage power supply is not available from the instrument, a separate and suitable power supply shall be provided by the User. For good operations of the measuring system, i.e. AN401 and transducer, power available from the external general power supply shall be greater than system power consumption; specific cares shall be taken if the system exhibits transient power consumption. Connections to DS Europe amplified transducers, covering most of applications, are described in paragraphs 3.7.1, 3.7.2 and 3.7.3 hereafter; in the following applications, the transducer is supplied directly by AN401 or by the external general power supply.

#### 3.7.1. A5 ( $\pm 5V$ ) AMPLIFIED TRANSDUCERS WIRING

Wiring diagram in fig. 12 shows how to connect a DS Europe transducer with A5 ( $\pm 5V$ ) amplified output which requires +12VDC (typical) power supply.

Using AN 401-24 model, the instrument can directly supply the transducer.

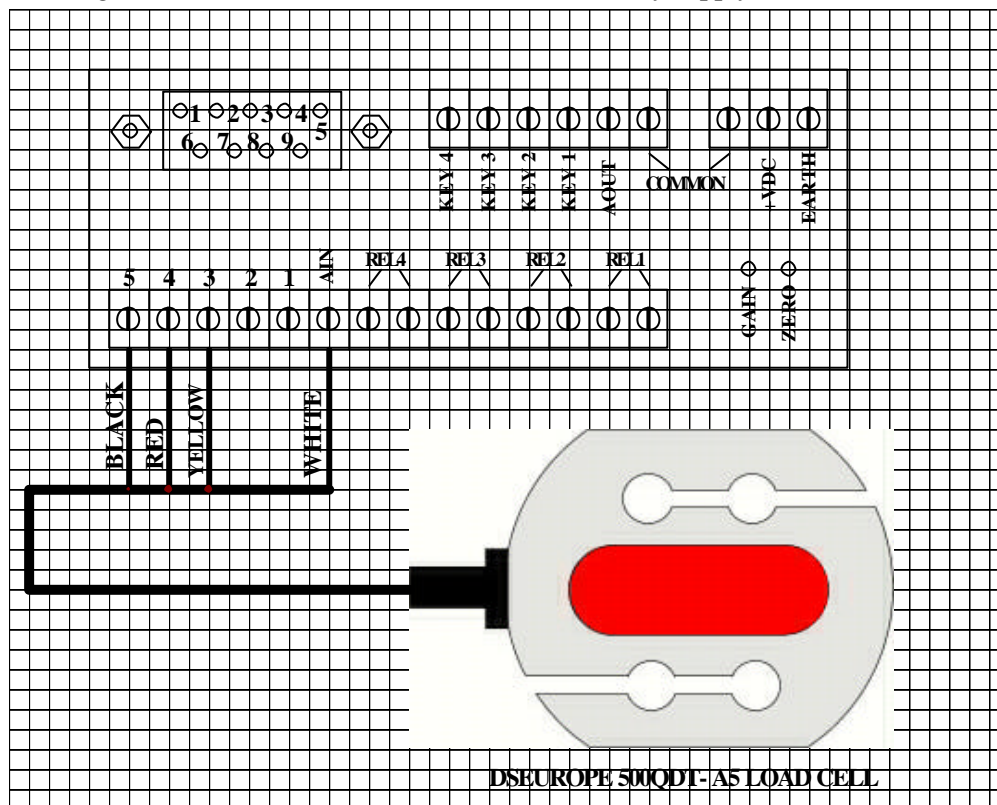

AN401 Terminal	Description
5	Power Supply (-)
4	Power Supply (+)
3	Calibration Input
AIN	Input Signal

**Fig. 12 Amplified Transducer (0±5V) Connections**

3.7.2. A10 (±10V) AMPLIFIED TRANSDUCERS WIRING

Wiring diagram in fig. 13 shows how to connect a DS Europe transducer with A10 (±10V) amplified output which requires +24VDC (typical) and +18VDC (minimum) power supply. In this application the transducer is supplied by the external power supply (24 VDC). 24VDC voltage shall be regulated very well. AN401-24 model is preferred to AN401-12 since the transducer is supplied directly from the external general power supply without any load for AN401.

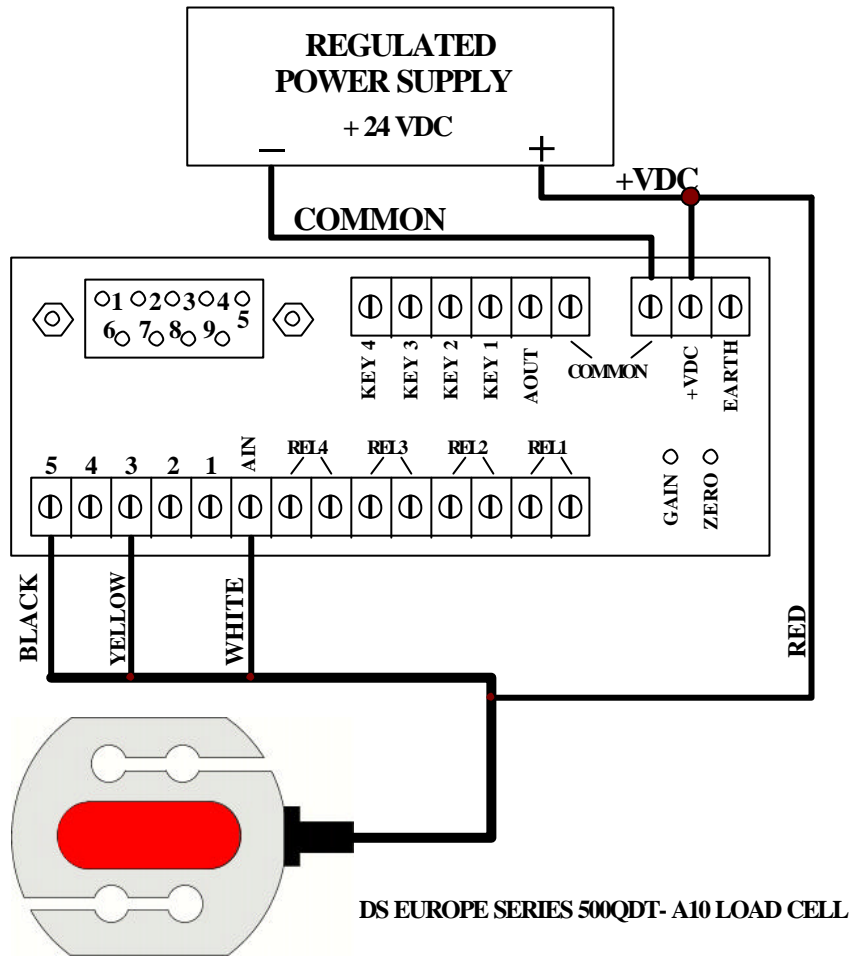

AN401 Terminal	Description
5	24 VDC external Power Supply (-)
3	Calibration Input
AIN	Input Signal

**Fig. 13 Amplified Transducer (0±10V) Connections**

3.7.3. SERVOINCLINOMETER ES200 OR OTHER ±15 V TRANSDUCER WIRING

Wiring diagram in fig. 14 shows how to connect a DS Europe servoinclinometer, model ES200, with amplified output (±5V) which requires ±15VDC (typical) power supply. In this application, the instrument cannot supply the transducer. It is suggested to use AN401-12 model, which can be supplied by regulated 15VDC, connected as in the wiring diagram below.

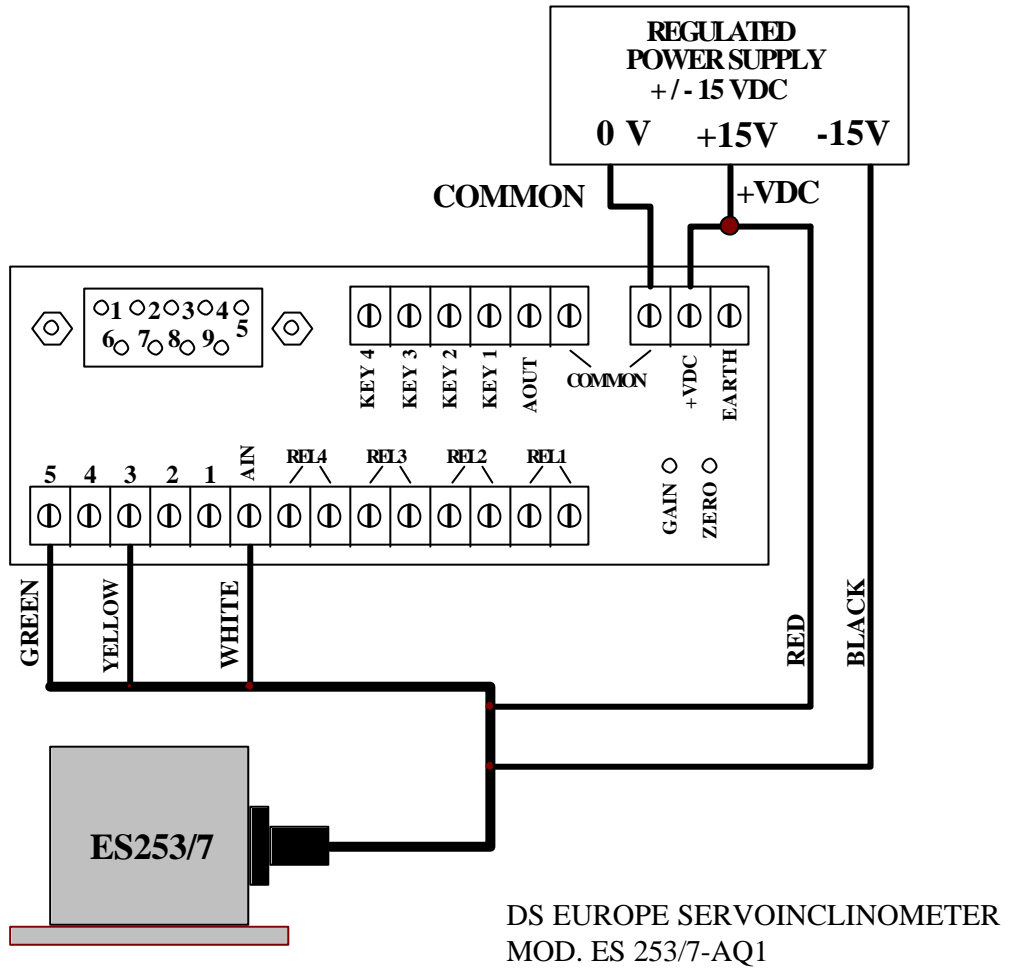

AN401 Terminal	Description
5	Common
3	Calibration Input
AIN	Input Signal

**Fig. 14** Servoinclinometer or ±15VDC Transducers Connections

### 3.8. DIGITAL INPUT WIRING

As described hereinbefore, up to four external command signals can be connected to AN401. These signals can be of two types as follows:

- mechanical switches (pushbuttons, relays, etc.)
- digital signals (TTL or CMOS)

To activate functions relevant to digital inputs, terminals KEY1-2-3-4 shall be connected to common (ground).

Voltage greater than +5V shall not be connected to these inputs since they are provided with internal pull-up resistors to +5VDC (internal digital power supply).

Mechanical and digital commands to these inputs can be mixed according to User's application, e.g. a relay contact can be connected to KEY1 and a TTL signal can be connected to KEY2.

See chapter 5 for the relation between digital inputs and instrument functions.

#### 3.8.1. DIGITAL INPUT FROM EXTERNAL MECHANICAL CONTACTS

Fig. 15 shows the wiring diagram when switches are used.

According to application, either un-stable or stable switches can be connected.

Relay contacts, instead of switches, can be connected in the same way.

It is possible to connect only the inputs required by the application without connecting unused inputs.

Inputs are active low, i.e. the function is activated when the relevant switch is closed to COMMON terminal (ground).

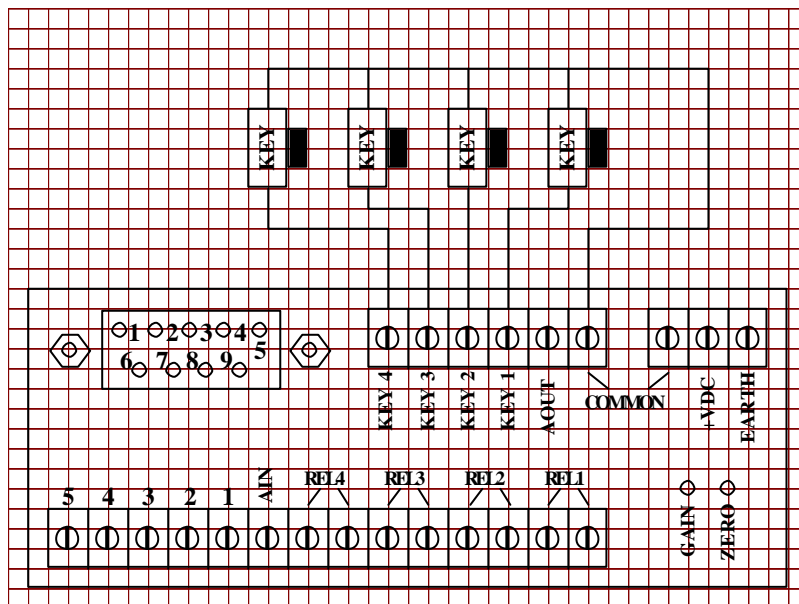

**Fig. 15** Digital or Manual External Commands Connections

### 3.8.2. DIGITAL INPUT FROM LOGIC SIGNALS

Either CMOS or TTL digital signals from other equipment can be connected to digital inputs. Inputs are active low, i.e. the function is activated when the relevant signal is at low logic level.

In this kind of application, logic signals shall be connected to terminals KEY1-2-3-4 while instrument ground and external equipment ground shall be connected together using COMMON terminal.

Even in this case it is possible to connect only the inputs required by the application without connecting unused inputs.

### 3.9. RELAY CONTACTS WIRING

Refer to the description given in paragraphs 3.2.11 through 3.2.14; it is reminded that relay contact rating is 1A max., 20VDC max.

Should switching of greater loads be required, then it is necessary to use more powerful external relays controlled by the internal ones.

This solution could be necessary even in case that AC loads are to be connected to the instrument: this way, noise generated by AC loads is not propagated inside the instrument.

### 3.10. SERIAL PORT WIRING

According to system configuration, different serial connections to the computer are required: in case of a system consisting of one instrument with one transducer, RS-232 serial port should be used; in case of a system consisting of several instruments with one transducer each, RS-485 multi-drop serial port should be used.

#### 3.10.1. RS-232 POINT-TO-POINT WIRING

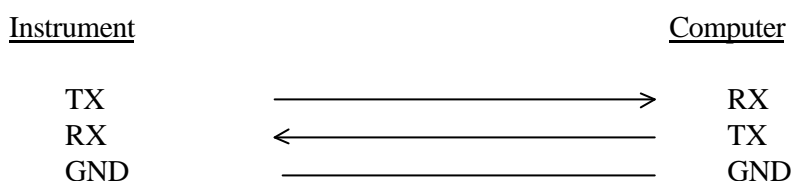

The most common wiring for RS-232 connection between AN401 and PC compatible computer is as follows:

	AN401 - RS 232		
	Computer		
	9-pin Connector	9-pin Connector	25-pin Connector
TX	2	3	2
RX	3	2	3
GND	5	5	7

The following setting of the serial port is required:

- Data bit = 8
- Parity = none
- Stop bit = 1

- Flow control = none

### 3.10.2. RS485 BIDIRECTIONAL MULTIDROP WIRING

The connection is achieved by means of a serial multi-drop wiring where data lines are in parallel among several devices and ground lines are commoned.

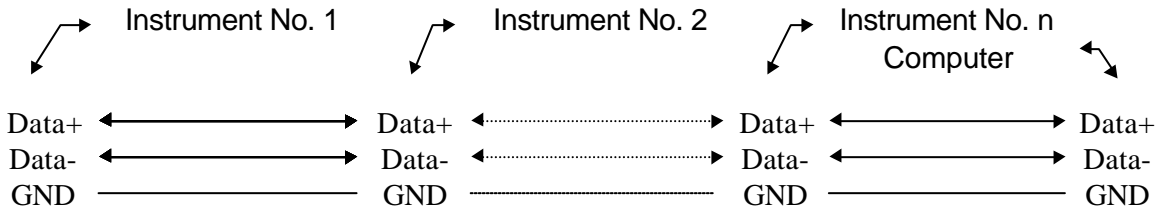

<b>AN401 - RS 485</b>	
9-pin Connector	
Data+	2
Data-	3
GND	5

### 3.10.3. GENERAL CONSIDERATIONS ON SERIAL LINES

Connection for communication serial lines should consider the following:

- *cable type*: the use of shielded twisted pairs is recommended since their immunity to noise is greater than non-shielded cables. Moreover, if necessary, use double shielded interconnecting cables. To obtain the best immunity to noise, paramount cares should be taken in earthing the interconnecting cable. It shall be connected such that ground loops, which could allow noise current to flow, are avoided. For shielding effectiveness, the User shall also check that the earthing point be a true reference point at null electric potential. If double shielded cables are used, it is suggested that *inner shield* be connected at one side (e.g. the transducer) and the *outer shield* be connected at the opposite side (e.g. the computer). This procedure shall also be followed when the interconnecting cable passes through a metallic tube to improve shielding. If necessary, it is also possible to consider the use of optocouplers for serial lines. However, the above shall be considered together with the specific application and shall be considered as suggestions only.
- *cable length*: the protocol, which defines RS-232 standard, recommends 15.2 meters as maximum interconnecting length between the device and the computer. For RS-485 serial connection, the relevant standard recommends 1,200 meters as maximum interconnecting length. As a matter of fact, the limits defined by reference standards are only theoretical limits and the achievable results are dependent on the characteristics of the application to a great extent.

In case of very long interconnecting cables, signals could be attenuated: this can be overcome using signal repeaters which are commonly on sale.

- *data transmission rate:* the two protocols, which have been considered for serial connections, have different data transmission rate limits:RS-232 is limited to 19,200 baud maximum, RS-485 is limited to 10 Mbaud maximum.  
For AN401, maximum data transmission rate is limited to 57,600 baud whichever standard is used.
- *electrical interface:* RS-232 electrical interface is “single ended”, i.e. data lines are referred to ground; in applications with high noise levels which can affect data transmission, RS-485 is preferred since the electrical interface of this standard is a differential interface: differential interface is less prone to noise than single ended interface.
- *number of devices on the same line:* using RS-232, only one device can be connected on the serial line; using RS-485, up to 32 devices can be connected on the same serial line.

Instruments of AN400 series shall be used according to the rules of the standards.

It is possible to use instruments with multi-drop RS-485 serial port together with computers, like a notebook, with only RS-232 serial port and without RS-485 port: this is possible using RS-232 to RS-485 converters; these converters shall be “transparent”, i.e. they shall completely support RS-485 protocol.

On sale, there are “passive” and “intelligent” converters; passive converters are just simple electrical level translators: for this reason, they shall be avoided; intelligent converters provide level translators, identification of data flow direction and automatic selection of data transmission rate.

It is suggested to choose an intelligent converter which can operate at the maximum used data transmission rate.

## 4. INSTRUMENT CALIBRATION PROCEDURES

---

The User can control functions, operating modes and instrument calibration by means of a software program installed inside the AN401.

**Note:** *since the display of AN401 is not an alphanumeric display, it is highlighted that messages displayed by the instrument to indicate menu items or parameters are necessarily stylized.*

### 4.1. INSTRUMENT POWER ON

For a general overview of power on sequence of the instrument, refer to fig. 16 where numeric references between square brackets [ ] highlight main steps; the same references are quoted within the text hereinafter.

At power on, **AN401** message is displayed followed few seconds later by the software version, e.g. **V. 1.00** [2]; then the selected function, e.g. **NET** weight, is displayed [4].

This way, at power on the instrument automatically selects the requested measurement function and therefore there is no need to select the function at each power on also avoiding that anybody can change the selected function except that intentionally.

At power on it is also possible to enter calibration and customization functions menus of AN401.

To enter setup and calibration menus, power on the instrument and at the same time press  $\theta$  (*down*) and C (*ESC*) pushbuttons [3].

The instrument will display the message **MAINT** [5] followed, on pushbuttons release, by the message **RDY** (ready) [7]: this means that AN401 is waiting for one of the following commands to enter different menus:

- pressing  $\theta$  (*down*) key, calibration menu is entered [9]; in this menu, all the parameters, which are used by the instrument to convert input voltage signal into a digital value, are defined.
- pressing E (*Enter*) key, customized functions menu is entered [10]; in this menu, operations of the instrument and its different functions are customized; also the conversion coefficient which allows to convert digital value into mechanical units is set in this menu.
- pressing  $\pi$  (*up*) key, clock setting menu is entered [8], provided that clock option of AN401 is installed.

To escape from above menus, press C (*ESC*) pushbutton and the instrument will return to **RDY** [7] status waiting to enter another menu or to escape setting mode.

To escape setting mode, press C (*ESC*) pushbutton when AN401 is displaying **RDY** [7]: this also stores the new settings of instrument parameters.

The instrument will perform a general RESET cycle [11] and will restart power on sequence from step [1].

Once the instrument enters the measuring mode (MEASURE [4] ), it is no more possible to enter setting mode except that switching off and on again the instrument.

The serial transmission to a remote computer is enabled when the instrument is in measuring mode (MEASURE [4] ) only; on the contrary, it is disabled whenever the instrument is in setting mode.

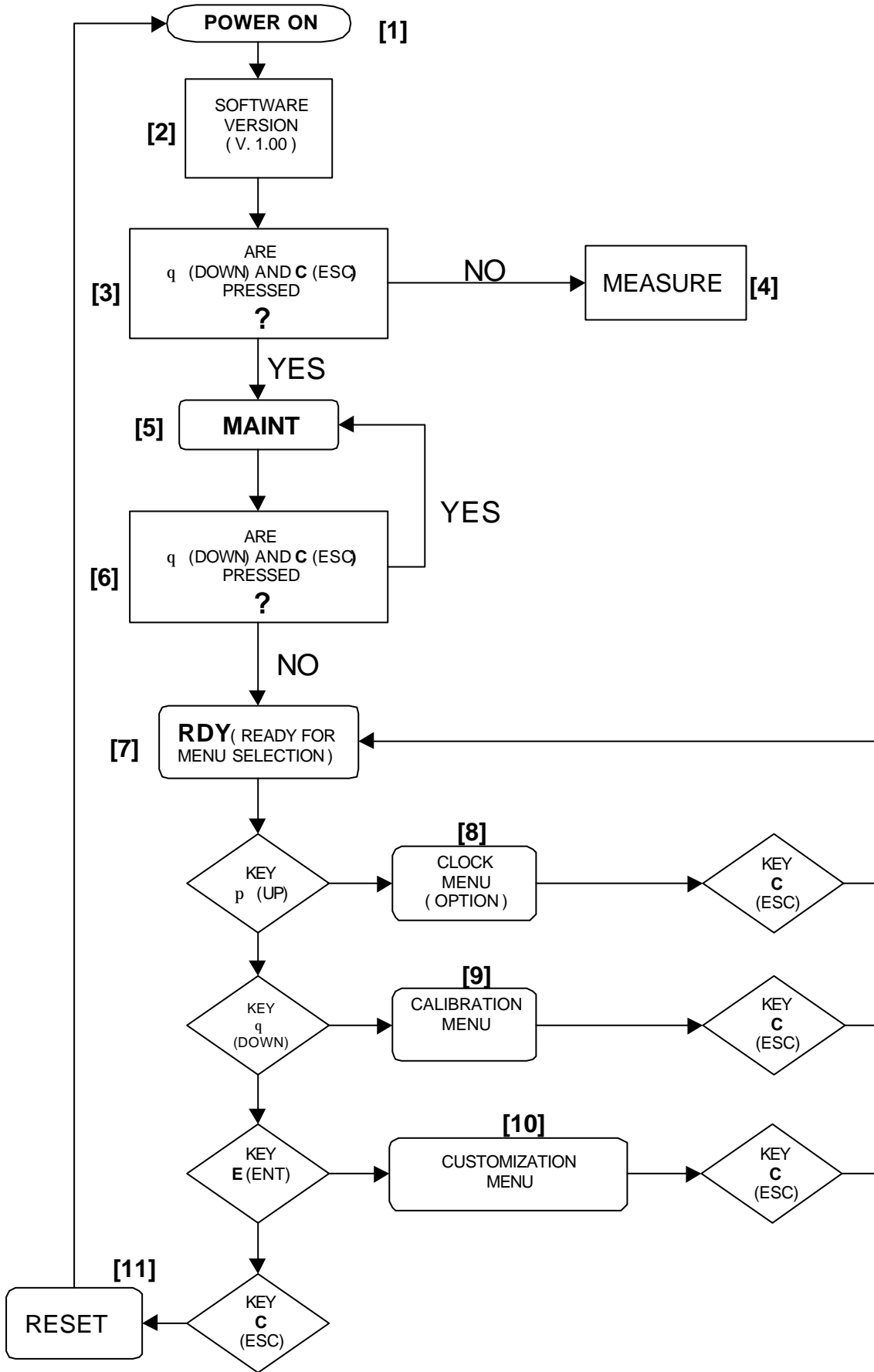

Fig. 16 Simplified Block Diagram of Standard Program

#### 4.2. CALIBRATION MENU

This menu allows to set allocation of A/D converter conversion points according to characteristics of the transducer, of the input signal and of the specific application of AN401.

The structure of calibration menu is as follows:

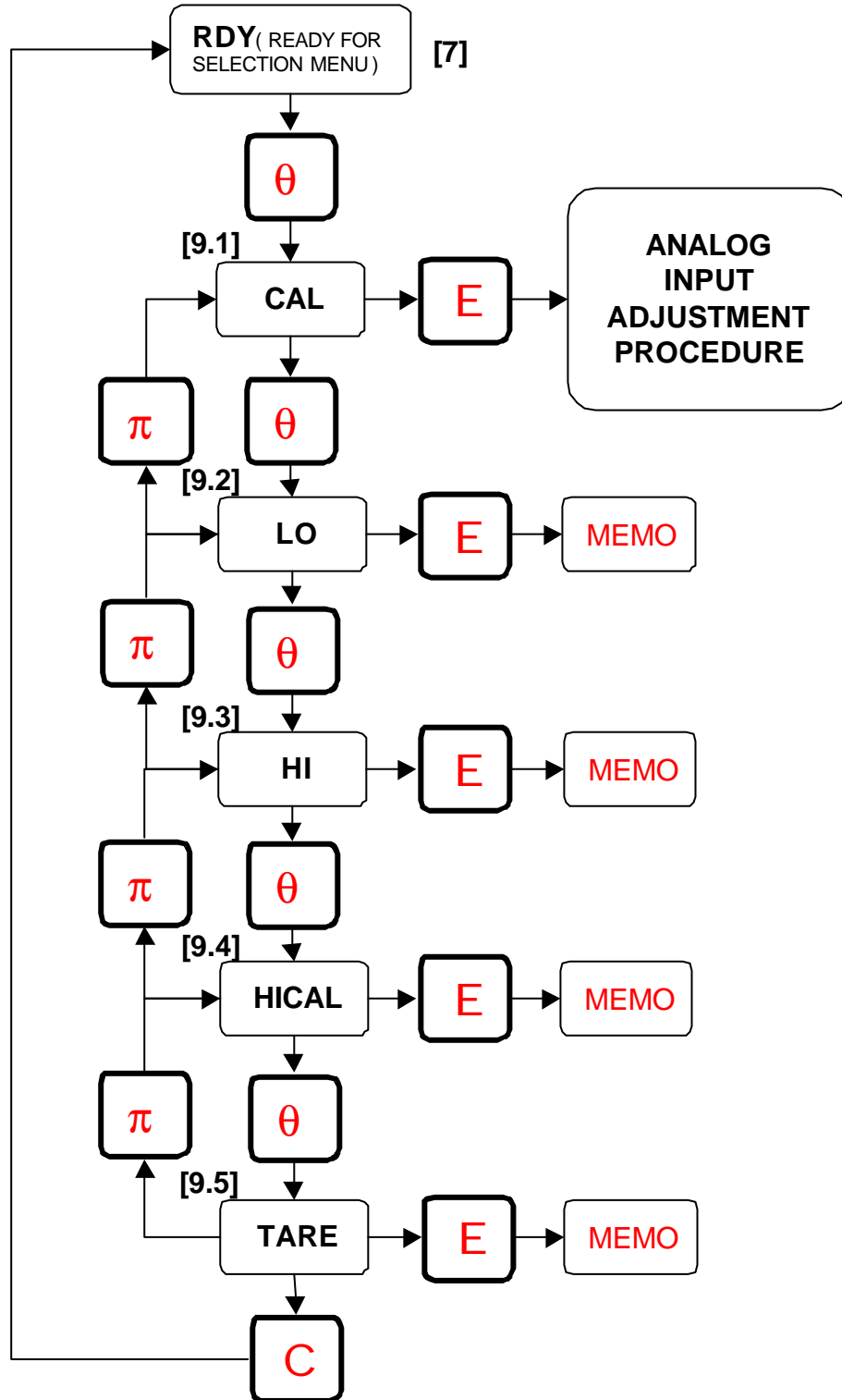

Fig. 17 Block Diagram of Calibration Menu

References [9.1] CAL, [9.2] LO, [9.3] HI, [9.4] HICAL, [9.5] TARE and MEMO show messages displayed by the instrument to identify different available menus.

As highlighted in fig. 17, press  $\theta$  (*down*) pushbutton to enter calibration menu from **RDY** [7] waiting status. The sequence of operations is shown in the block diagram of fig. 17 where:

- $\theta$  (*down*) and  $\pi$  (*up*) pushbuttons allow to move from one menu to another one
- E (*Enter*) pushbutton allows to store the set value (MEMO)
- C (*ESC*) pushbutton allows to return to **RDY** [7] waiting status

#### 4.2.1. ANALOG INPUT ADJUSTMENT (CAL)

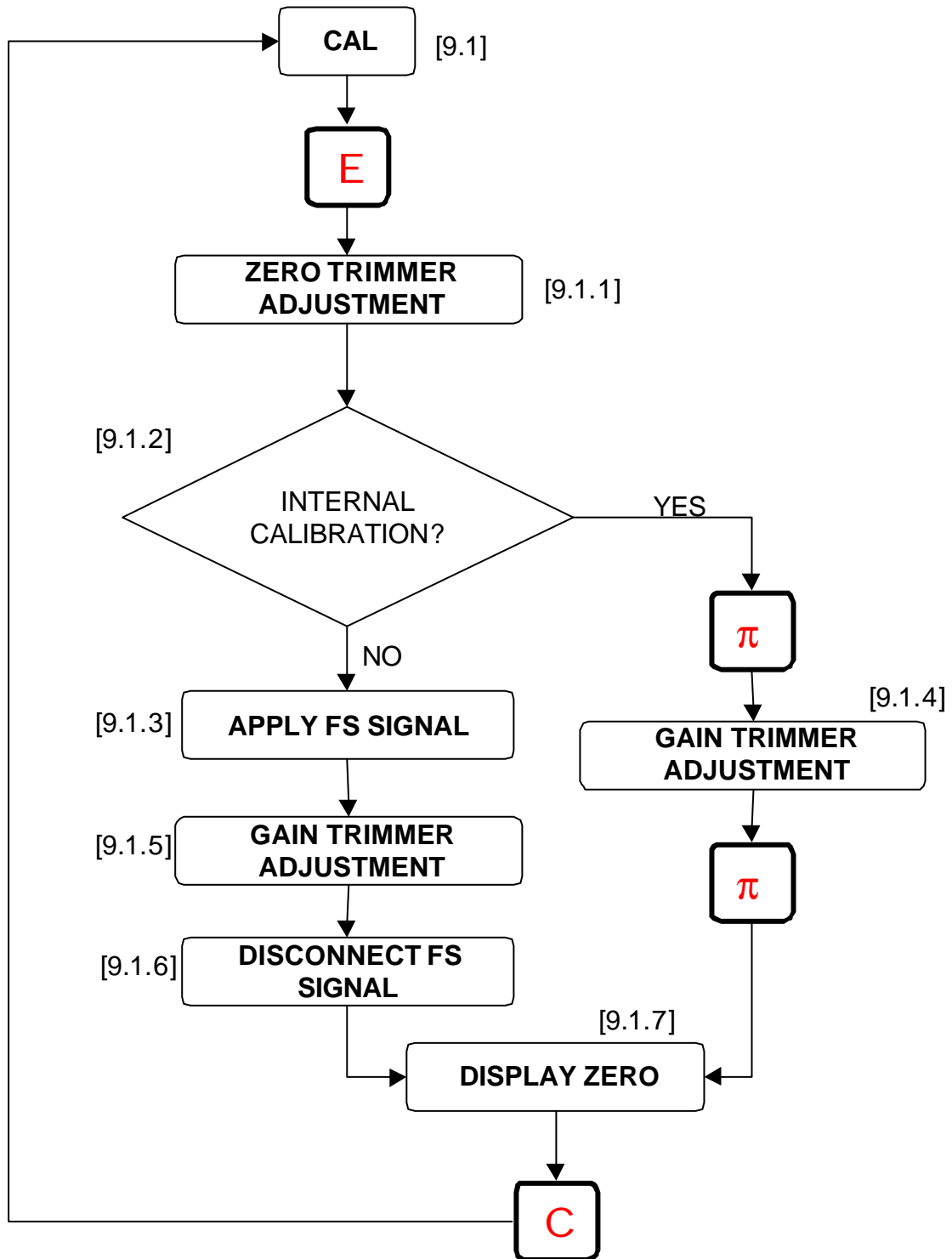

**Fig. 18 Calibration Procedure of Analog Input**

**PROCEDURE**

For instrument operations, it is necessary to allocate of available conversion points (65,535 points). This is achieved setting minimum and maximum values of conversion points which will correspond to minimum and maximum values of analog signal.

Setting is carried out by means of ZERO and GAIN trimmers which control minimum and maximum values of conversion points respectively.

During adjustment, the display shows the current value of conversion points as consequence of trimmer adjustment.

The sequence for setting values necessary to AN401 operations is as follows:

- a) From menu CAL [9.1], press E (*Enter*) to display minimum value of conversion points [9.1.1].
- b) With unloaded transducer (in case of a load cell) or with transducer at null position (servoinclinometers or displacement transducers), adjust ZERO trimmer until the required value is displayed.  
Zero value is typically in the range 200 to 1000 conversion points for an input signal ranging from 0 to +5V (refer to paragraph 4.2.6 for other cases).
- c) After having applied to the analog input of the instrument the signal to be matched to the desired maximum value of conversion points, adjust GAIN trimmer until the desired value (of conversion points) is displayed.  
Depending on whether a calibration signal simulating the maximum input is available or not from the transducer, the procedure shall be carried out in two different ways as detailed in d) and e) hereafter.
- d) *Calibration signal is available*: pressing  $\pi$  (*up*) key, calibration circuit is activated and the instrument displays the corresponding value as conversion points [9.1.4] on condition that electrical connections are in accordance with paragraph 3.2.3.  
This operation shall be performed with unloaded transducer (in case of a load cell) or with transducer at null position (servoinclinometers or displacement transducers): this is to avoid that the value measured by the transducer can jeopardize calibration signal.  
Setting the desired conversion points is achieved adjusting GAIN trimmer; it is to be considered that, generally, signal simulated by calibration circuit is less than full scale (FS) signal and therefore it is suggested to use less than maximum available conversion points.  
Generally, it is preferred to leave some margin between conversion points corresponding to calibration signal and conversion points corresponding to FS.  
After trimmer adjustment, press again  $\pi$  (*up*) pushbutton to disable calibration circuit and return to display of ZERO conversion points [9.1.7].  
Example: suppose that the range of input signal is 0 to +5V (FS) and that calibration signal is 75% of FS (i.e. 3.75V); supposing also that there are 65000 available conversion points and that ZERO is set to 1000 conversion points, then adjust GAIN trimmer until instrument displays 48000 conversion points.
- e) *Calibration signal is not available*: load the transducer to FS so that FS signal is applied to the input of the instrument [9.1.3]; then adjust GAIN trimmer [9.1.5] until the number of conversion points desired for full scale is displayed.  
After trimmer adjustment, unload the transducer [9.1.6] and return to display of ZERO conversion points.  
During the above operations, the instrument displays the value of conversion points.
- f) ZERO and GAIN adjustments may influence each other: therefore it is suggested to reiterate the procedure, steps b)+d) or b)+e), until the desired values are obtained.

- g) On completion of above operations, press C (*ESC*) pushbutton to return to calibration menu (CAL) [9.1].

### **WARNING MESSAGES**

During ZERO and GAIN adjustment, the instrument may display the following warning messages:

- **C-LO:** this means that the instrument detects that ZERO trimmer has been adjusted for a too small value of conversion points.  
Adjust ZERO trimmer until the instrument displays a numerical value of conversion points.
- **C-HI:** this means that the instrument detects that GAIN trimmer has been adjusted for a too high value of conversion points.  
Adjust GAIN trimmer until the instrument displays a numerical value of conversion points.

#### 4.2.2. MINIMUM READING VALUE (LO)

Minimum reading value [9.2] is the minimum value of conversion points to be assigned to zero of input signal.

This function is used to store into AN401 the value set in paragraph 4.2.1.b by means of ZERO trimmer.

From CAL menu, enter LO menu pressing  $\theta$  (*down*) pushbutton; before storing the value, check that no load is applied to the transducer or that the transducer is at null position.

To store the value, press E (*Enter*) key: the instrument will display the message MEMO for few seconds and then it will return to LO menu.

#### 4.2.3. MAXIMUM VALUE (HI)

If d) procedure of paragraph 4.2.1 has been used, then refer to paragraph 4.2.4.

Maximum reading value [9.3] is the maximum value of conversion points to be assigned to full scale input signal.

This function is used to store into AN401 the value set in paragraph 4.2.1.e by means of GAIN trimmer.

From LO menu, enter HI menu pressing  $\theta$  (*down*) pushbutton; before storing the value, check that full scale load is applied to the transducer or that the transducer is at full scale position.

To store the value, press E (*Enter*) key: the instrument will display the message MEMO for few seconds and then it will return to HI menu.

#### 4.2.4. MAXIMUM VALUE (HICAL)

If e) procedure of paragraph 4.2.1 has been used, then refer to paragraph 4.2.3.

Maximum reading value [9.4] is the maximum value of conversion points to be assigned to the input signal simulated by the calibration circuit.

This function is used to store into AN401 the value set in paragraph 4.2.1.d by means of GAIN trimmer.

Check that electrical connections are in accordance with description of paragraph 3.2.3.

From HI menu, enter HICAL menu pressing  $\theta$  (*down*) pushbutton; before storing the value, check that no load is applied to the transducer or that the transducer is at null position.

During storing phase, the instrument automatically enables calibration circuit of the transducer.

To store the value, press E (*Enter*) key: the instrument will display the message MEMO for few seconds and then it will return to HICAL menu.

#### 4.2.5. TARE

The tare [9.5] applied to a weighing system determines the number of conversion points that is to be added to the number of conversion points set as to ZERO.

This function is used to store the value of tare that will be automatically taken into account by the instrument when computing conversion coefficient between conversion points and mechanical units.

From HICAL menu, enter TARE menu pressing  $\theta$  (*down*) pushbutton; before storing the value, check that the tare is applied to the transducer or to the weighing system.

The use of this function is not limited to load cells only, but it can be used with any transducer to provide an offset to zero.

To store the tare value, press E (*Enter*) key: the instrument will display the message MEMO for few seconds and then it will return to TARE menu.

#### 4.2.6. CALIBRATION HINTS

Available conversion points (65535) shall be allocated considering the characteristics of the signal and considering the conversion from conversion points to required mechanical unit to be carried out by the instrument.



When setting ZERO and GAIN values by means of the relevant trimmers, allocation of conversion points shall also consider the need of leaving some safety margin below the value set as ZERO and above the value set as GAIN.

Should the signal become equal to the value corresponding to ZERO and GAIN adjustments, margins avoid instrument from blocking and displaying ERROR due to A/D converter under/overflow.

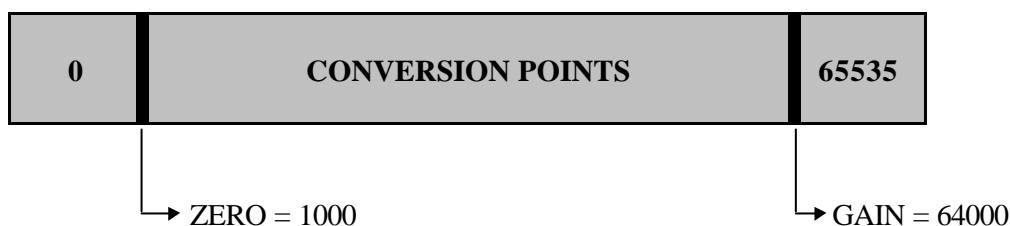

*Conversion points allocation vs. “zero” and “gain” limits (typical values)*

The definition of the number of conversion points to be set by means of GAIN trimmer shall also consider advantages and disadvantages of analog signal amplification needed to use all the conversion points.

An advantage of increasing GAIN adjustment is that the maximum available number of conversion points are used.

A disadvantage of increasing GAIN adjustment is that not only the input signal to be displayed, but also the noise superimposed is amplified: this causes less significant digits of the display to be unstable requiring digital filtering.

This also happens when the transducer is subjected to vibrations or when its mode of operation is pulsed.

In this case, decreasing GAIN to minimum needed to obtain desired resolution, and therefore decreasing the number of conversion points allocated to GAIN, could be advantageous.

Calibration shall consider two possibilities:

- the input signal is unipolar, i.e. it ranges from 0 to + full scale (+FS)
- the input signal is bipolar, i.e. it ranges from - full scale (-FS) to + full scale (+FS)

Available conversion points shall be allocated accordingly to the above by means of ZERO and GAIN adjustments.

**a) Unipolar signal (0 to +FS)**

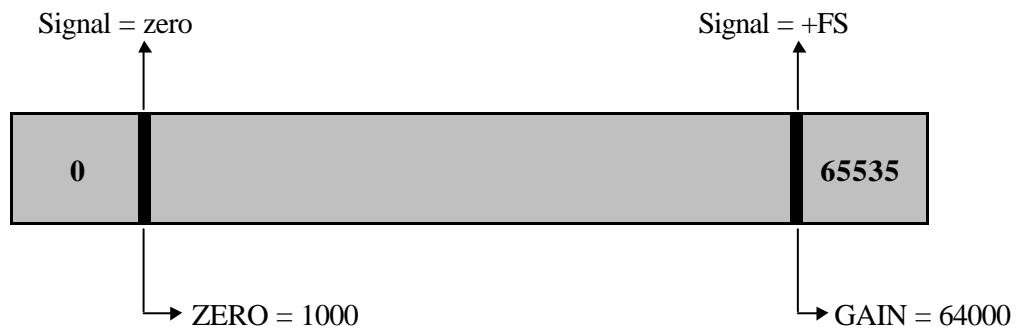

*Conversion points allocation for unipolar signal (typical values)*

This is the most simple case and it is applicable to pressure transducers, load cells (used in compression only or in traction only) and displacement transducers; it is also applicable both to single ended and to differential signals without differences.

On the contrary, should the input signal range from 0 to -FS, then the value  $GAIN = 64000$  shall be associated to  $Signal = zero$ , while the value  $ZERO = 1000$  shall be associated to  $Signal = -FS$

The above values for ZERO and GAIN shall be considered as suggestions only.

**b) Bipolar signal (-FS to +FS)**

The zero of the signal is centered between negative and positive full scale values.

In this case, conversion points shall be equally allocated between the two polarities of the signal, i.e. about 31500 points for +FS and the same for -FS.

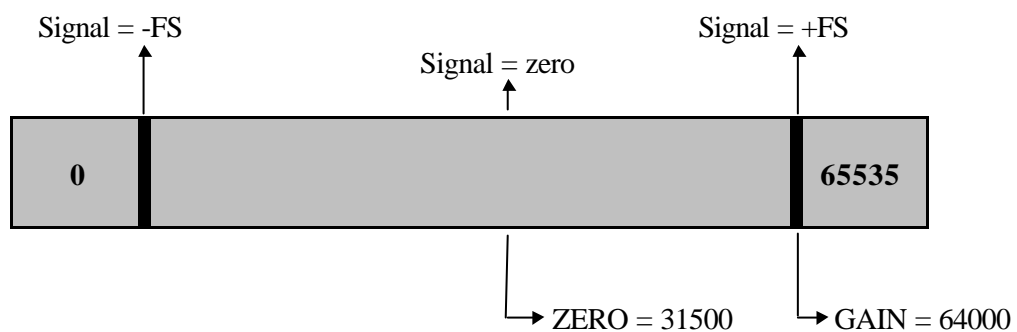

*Conversion points allocation for bipolar signal (typical values)*

The above is applicable to servoinclinometers, LVDT displacement transducers, load cells (used in compression and in traction) and to any transducer with centered zero.

**c) Tare**

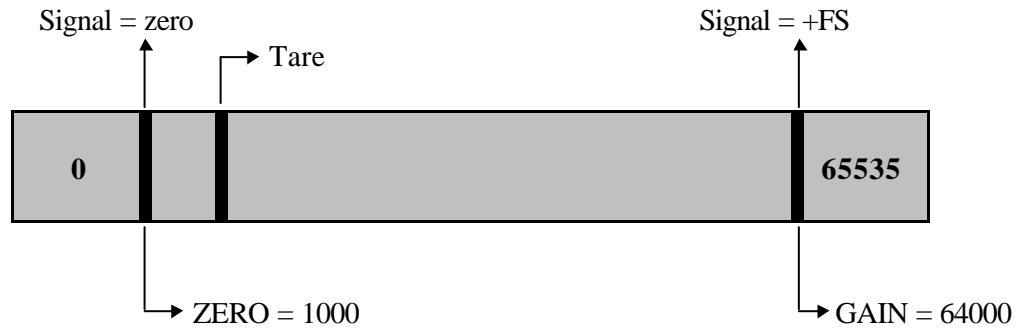

*Conversion points allocation with tare (typical values)*

In weighing systems, automatic deduction of tare is of great importance; in different applications, tare can also be considered as a dummy offset to be deducted from the measure (e.g. hydraulic pressure of the line).

Using AN401 instrument, tare can be deducted in three different ways:

- *Using TARE function [9.5]:* this is the suggested method since it allows to read tare and to consider it when necessary.
- *Using ZERO trimmer [4.2.1]:* this method should be avoided since any change of tare requires the complete re-calibration of the instrument.
- *Setting tare value in the instrument:* to use this method, see procedure described in paragraph 4.3.8.

**d) Summing Units**

Calibration of a system consisting of AN401, of a summing unit and of 2 to 4 transducers requires adjusting both the summing unit and the instrument.

The proposed procedures are applicable to DS Europe load cells and to summing units AN-371 (output signal  $\pm 80$  mV FS) or EL-574 (output signal  $\pm 5$  V FS); it is to be noted that electrical connections and output signals of the two models of summing units are different (see paragraph 3.6 for connections between AN401 and AN-371, see paragraph 3.7.1 for connections between AN401 and EL-574).

*It is preferable* to calibrate first the sub-system consisting of the summing unit together with load cells and then calibrate the AN401 together with the sub-system using a *simplified calibration procedure*.

See technical manuals of AN-371 and EL-574 for their calibration procedure.

**Simplified Procedure**

1. Connect summing unit to load cells and calibrate the summing unit using a digital multimeter or a voltmeter.
2. Connect AN401 to AN-371 (see paragraph 3.6) or to EL-574 (see paragraph 3.7.1).

3. Perform AN401 *analog input adjustment* in accordance with the procedure described in paragraph 4.2.1.

When a summing unit is connected to AN401, then:

- a) Calibration circuit of transducers cannot be enabled pressing  $\pi$  (*up*) pushbutton of AN401; calibration circuits (if available) can be enabled/disabled operating on the summing unit.
- b) Calibration circuits of all transducers shall be enabled at the same time if they are used during AN401 calibration.  
The resulting signals is the sum, in mechanical units, of calibration values (= *calibration equivalent load*) of each transducer.

If the summing unit cannot be calibrated independently from AN401, the instrument can be used to calibrate the summing unit together with load cells; AN401 can be calibrated afterwards.

This procedure should be avoided since it is more complicated than previous procedure.

**Note:** connecting load cells to the summing unit (AN-371 or EL-574) an increasing sensitivity order shall be followed: load cell with the lowest sensitivity shall be connected as load cell no.1, while load cell with the highest sensitivity shall be connected as load cell no.4.

### **Procedure using AN401 as a Voltmeter**

1. Start from CAL menu [9.1].
2. Set to minimum GAIN trimmer of AN401 (do not stress it).
3. Connect the cells to be summed (2,3 or 4) to the summing unit according to instruction manual of summing unit.
4. Adjust ZERO trimmer of *AN401* until it displays a value of 200 points approximately.
5. Close calibration jumper of cell no. 1 *on summing unit*.
6. Adjust GAIN trimmer *of summing unit* until AN401 displays the calibration value in mechanical units (as reported on the transducer certificate) plus the value set at point 4., as the ZERO of AN401 (200 points).

Example:

Load cell 535QD - 12Kg full scale

Calibration (calibration equivalent load) = 7.11857 Kg

Adjust GAIN trimmer of the summing unit until AN401 displays 7318 = 7118+200 (only significant digits, which can be displayed by the instrument, are considered).

7. Remove calibration jumper and, if necessary, adjust ZERO trimmer *of the summing unit* until AN401 displays the value set at step 4. above (200 points).
8. Repeat steps 5,6 and 7 until required values of ZERO and calibrations are obtained.
9. Close calibration jumper of cell no. 2.
10. Adjust sensitivity trimmer of cell no.2 *of summing unit* until AN401 displays the calibration value in mechanical units (as reported on the transducer certificate) plus the value set at point 4., i.e. the ZERO of AN401 (200 points).

Example:

Load cell 535QD - 12Kg full scale

Calibration (calibration equivalent load) = 7.21568 Kg

Adjust sensitivity trimmer *of the summing unit* until AN401 displays 7415 = 7215+200 (only significant digits, which can be displayed by the instrument, are considered).

11. Open calibration jumper to display ZERO value; if necessary, adjust ZERO trimmer of the summing unit until AN401 displays the value set at step 4. above (200 points).
12. Repeat steps 9,10 and 11 until required values of ZERO and calibrations are obtained.
13. Repeat above steps for remaining cells.
14. If necessary, adjust ZERO trimmer *of the summing unit* until AN401 displays the value set at step 4. above (200 points).
15. Close all calibration jumpers *of the summing unit*: AN401 will display the sum of all calibrations + 200.
16. If the value of the sum is different from the computed value, adjust GAIN trimmer *of the summing unit* until the required value is obtained.
17. Remove calibration jumpers and check ZERO value (200 points); if necessary, adjust ZERO trimmer of the summing unit until AN401 displays 200 points.
18. Repeat steps 16,17 and 18 until required values of ZERO and calibrations are obtained.
19. Perform AN401 *analog input adjustment* according to procedure of paragraph 4.2.1.

Adjustments for DS Europe summing unit:

	ZERO	GAIN	Sensitivity
EL-574	Zero	Gain	Can 2 Can 3 Can 4
AN-371	P2	P1	P3 P4 P5

This table gives cross-reference between trimmers (ZERO, GAIN and SENSITIVITY) and markings on summing units.

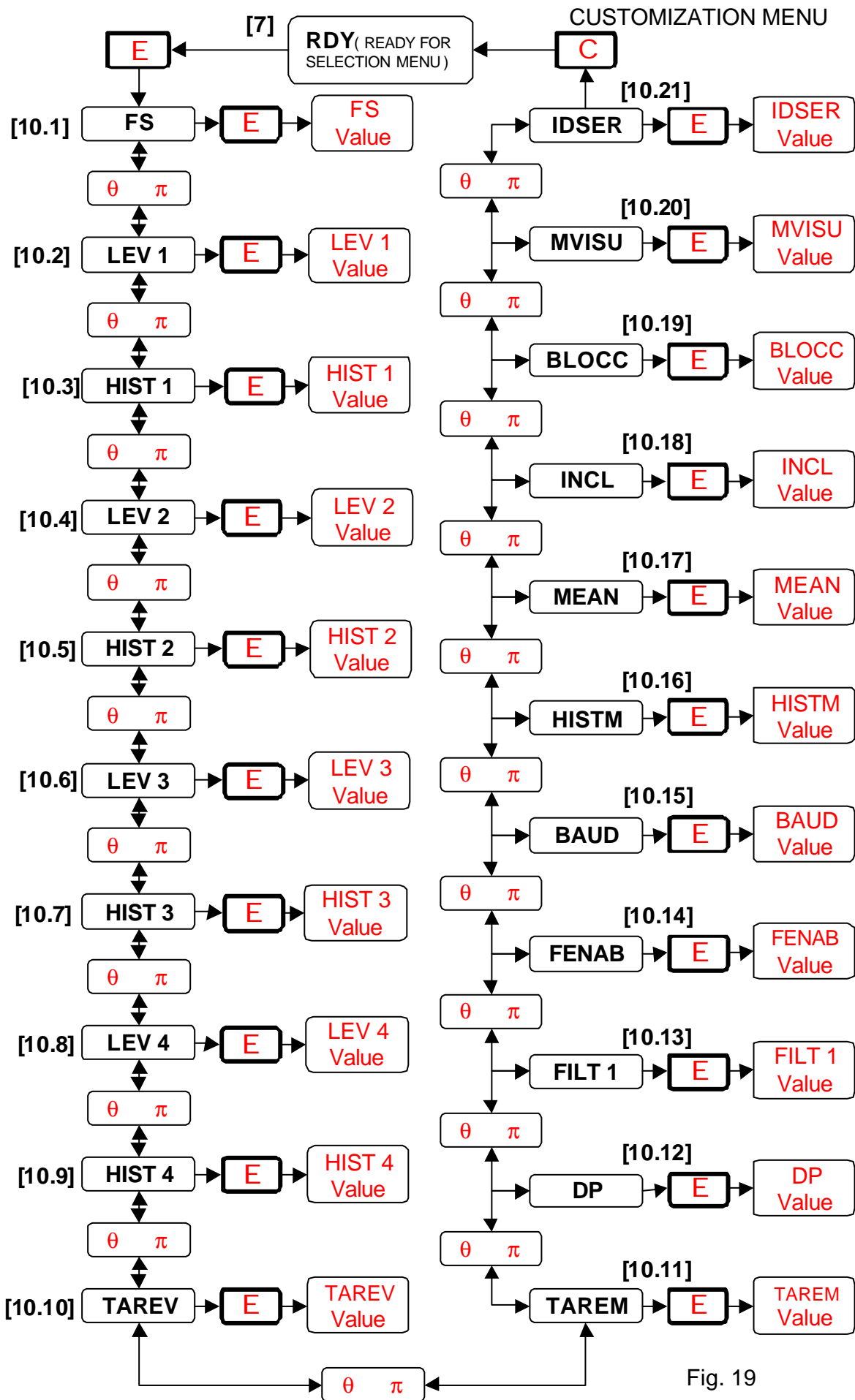

Fig. 19

### 4.3. CUSTOMIZATION MENU

Customization menu allows to change operating modes of the instrument, i.e. to set:

- the conversion value between A/D converter measurements and mechanical units to be displayed;
- the values of limit levels and their hysteresis;
- decimal point position;
- digital filters;
- baud rate of serial communication, etc.

From **RDY** [7] waiting status, press **E** (*Enter*) pushbutton to enter customization menu: the instrument displays the first item of the menu **FS** [10.1] (**FS** = full scale); see fig. 16 and fig. 19).

All the items of the menu are in a closed loop:

- press  $\pi$  (*up*) pushbutton to move to next item
- press  $\theta$  (*down*) pushbutton to move to previous item
- press **C** (*ESC*) to escape at any time and return to **RDY** [7] waiting status

Each item of the menu is displayed by a message, which indicates the name of the parameter.

Just press **E** (*Enter*) pushbutton to display present value of the parameter.

Press  $\pi$  (*up*) pushbutton to increase the value, press  $\theta$  (*down*) pushbutton to decrease the value.

At the beginning, parameter changes by units, then keeping the pushbutton pressed the parameter changes by tens and afterwards by hundreds.

Press **E** (*Enter*) pushbutton to store the new value and then press **C** (*ESC*) pushbutton to return to parameters menu; just press **C** (*ESC*) pushbutton without pressing **E** (*Enter*) pushbutton to return to parameters menu without storing the new value (original value is maintained).

After changes to parameters have been completed, press **C** (*ESC*) pushbutton to return to **RDY** [7]

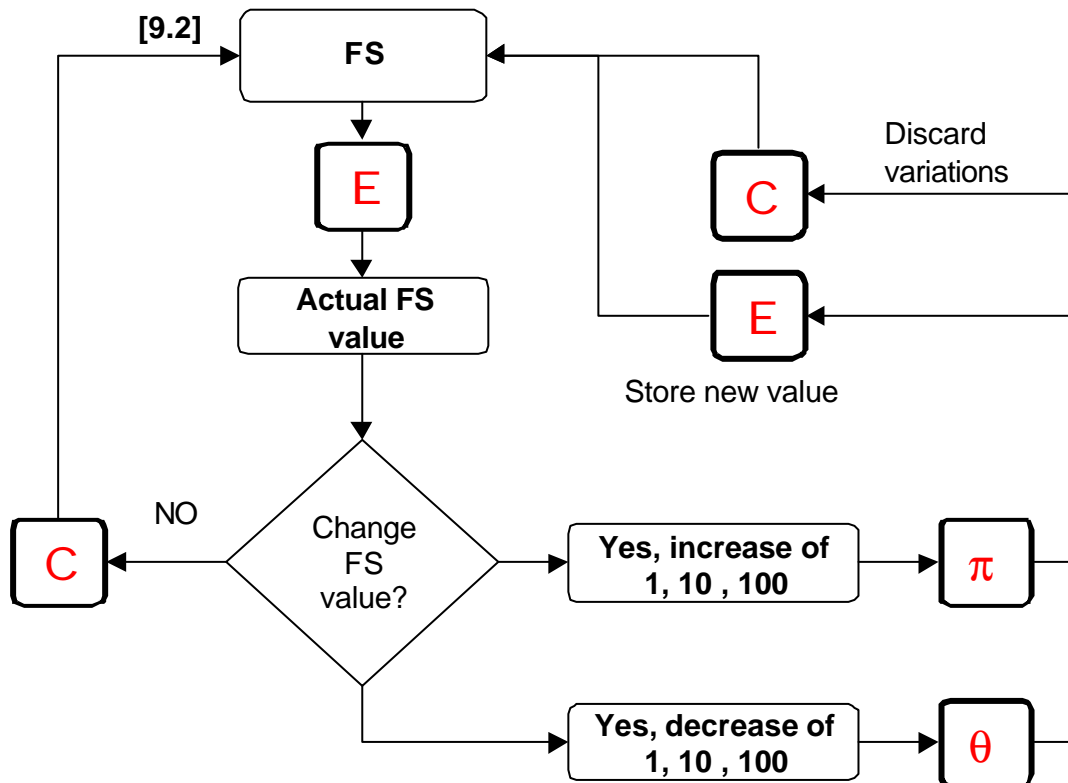

waiting status.

**Fig. 20 Example of Changes to Full Scale (FS) Value**

The procedure highlighted in fig. 20 shows the sequence of operations to be followed to display and, in case, to modify all the parameters of the customization menu (from [10.1] to [10.20]).

All the parameters of the customization menu (from [10.1] to [10.20]) are represented by a numerical value with the following setting limits:

Display Indication	Minimum Value	Maximum Value	Parameter Description
FS	-99999	+99999	To set the value of FS, in the chosen mechanical units, to be associated to the maximum of conversion points of the instrument <b>[10.1]</b>
LEV 1	-99999	+99999	To set the value of limit level no. 1 <b>[10.2]</b>
HIST 1	-1	50	To set the value of hysteresis for level no. 1 <b>[10.3]</b> The value -1 disables level no. 1
LEV 2	-99999	+99999	To set the value of limit level no. 2 <b>[10.4]</b>
HIST 2	-1	50	To set the value of hysteresis for level no. 2 <b>[10.5]</b> The value -1 disables level no. 2
LEV 3	-99999	+99999	To set the value of limit level no. 3 <b>[10.6]</b>
HIST 3	-1	50	To set the value of hysteresis for level no. 3 <b>[10.7]</b> The value -1 disables level no. 3
LEV 4	-99999	+99999	To set the value of limit level no. 4 <b>[10.8]</b>
HIST 4	-1	50	To set the value of hysteresis for level no. 4 <b>[10.9]</b> The value -1 disables level no. 4
TAREV	-99999	+99999	To set the value, if known, of the tare in mechanical units <b>[10.10]</b>
TAREM	0	1	For TAREM=0 <b>[10.11]</b> , the tare measured by AN401 (by means of TARE function [9.5]of calibration menu) is enabled (see paragraph 4.2.5). For TAREM=1, the tare is set to the value entered in TAREV <b>[10.10]</b>
DP	1	5	To set the position of decimal point starting from the right. For DP=1, all decimal points are switched OFF <b>[10.12]</b>
FILT 1	20	250	To set the value of the digital RC filter <b>[10.13]</b>
FENAB	0	1	For FENAB=1 <b>[10.14]</b> , the digital filter FILT 1 <b>[10.13]</b> is enabled
BAUD	0	7	To set the baud rate of serial communication from 600 to 57,600 baud <b>[10.15]</b>
HISTM	1	50	To set hysteresis applicable to the display of the value measured by AN401 <b>[10.16]</b> . For HISTM=0 the function is disabled
MEAN	0	20	To set the number of measures the average of which is displayed by the instrument <b>[10.17]</b>
INCL	0	4	To enable inclinometer function and set the full scale to 14.5° (for INCL=1), to 30° (for INCL=2), to 45° (for INCL=3), to 90° (for INCL=4); for INCL=0 the converting algorithm is disabled <b>[10.18]</b>
BLOCC	0	1	For BLOCC=1 <b>[10.19]</b> , the values of limit levels can be modified even in MEASURE mode [4] without entering customization menu. For BLOCC=0, the values of limit levels cannot be modified in MEASURE mode [4]
MVISU	0	4	To set display mode <b>[10.20]</b> of AN401: for MVISU=0, NET weight is displayed for MVISU=1, GROSS weight is displayed for MVISU=2, PIECE-COUNTER is displayed for MVISU=3, ERROR is displayed

			for MVISU=4, COMBINED display mode of measurement functions is activated
IDSER	0	99	To set the number of serial address of the instrument [10.21]. This has to be a unique value in the group of instruments connected to the same serial communication line

#### 4.3.1. CONVERSION TO MECHANICAL UNITS AND RESOLUTION

To give a meaning to the number of conversion points resulting from A/D conversion of the analog signal, a coefficient shall be given to the instrument to convert conversion points into mechanical units to be displayed.

For AN401, this is achieved entering the full scale value (=FS) [10.1], in mechanical units (mm, Kg, inch, bar, etc.), which is associated by the instrument to the number of conversion points stored at step HI [9.3] or HICAL [9.4] and adjusted by means of GAIN trimmer.

The definition of full-scale value is also depending on:

- *Position of decimal point, DP.* For computing convenience, all the numbers are treated by AN401 as integer numbers; to obtain the display of a decimal number, the FS value shall be multiplied by 10 raised to the number of required decimals.  
For DP=1 [10.12], all the decimal points will be switched off since the first position corresponds to the decimal point of the rightmost digit of the display.
- *Number of conversion points.* The number of conversion points is strictly dependent on the FS value to be set [10.1]. It is suggested that conversion points be equal to FS value or equal to a multiple of FS value: this increases accuracy in computing conversion coefficients since less rounding is necessary.

##### Example no. 1

Connecting AN401 to a linear displacement transducer with 500 mm FS, the following displays can be obtained:

FS Display (mm)	Resolution	DP Value [10.12]	FS Value [10.1]	Conversion points (GAIN)
500	1 mm	1	500	500
500.0	0.1 mm	2	5000	5000
500.00	0.01 mm	3	50000	50000

##### Example no. 2

Connecting AN401 to a servoinclinometer with +90° FS, the following displays can be obtained (INCL=3 [10.18] is to be set):

FS Display (degree)	Resolution	DP Value [10.12]	FS Value [10.1]	Conversion points (GAIN)
90	1 °	1	90	90
90.0	0.1 °	2	900	900
90.00	0.01 °	3	9000	9000

##### Example no. 3

Connecting AN401 to a servoinclinometer with ±90° FS, the following displays can be obtained (INCL=3 [10.18] is to be set):

FS Display (degree)	Resolution	DP Value [10.12]	FS Value [10.1]	Conversion points (ZERO)	Conversion points (GAIN)
90	1 °	1	90	1000	1090

90.0	0.1 °	2	900	2000	2900
90.00	0.01 °	3	9000	10000	19000

*Rounding of displayed value:*

They are due to the conversion of units of measure (from electrical to mechanical units) or to a mechanical quantity to be displayed greater than the number of conversion points.

4.3.2. LIMIT LEVELS AND HYSTERESIS

For each of the four limit levels of AN401, the threshold value [10.2], [10.4], [10.6], [10.8] and the relevant hysteresis [10.3], [10.5], [10.7], [10.9] can be defined individually.

Threshold values can be set in the range  $\pm 99999$  mechanical units according to User's convenience. Threshold values are referred to the value measured by NET function.

The band of activation of limit levels is defined by setting hysteresis values; this band is centered on the relevant limit level as follows:

- a) *for increasing signal*, the relevant relay (e.g. no. 1) is activated at **t1**, i.e. when the signal reaches the sum of the values of limit level no. 1 and hysteresis no. 1 (LEV 1+ HIST 1);
- b) *for decreasing signal*, the relevant relay (e.g. no. 1) is deactivated at **t3**, i.e. when the signal reaches the difference between the values of limit level no. 1 and hysteresis no. 1 (LEV 1- HIST 1).

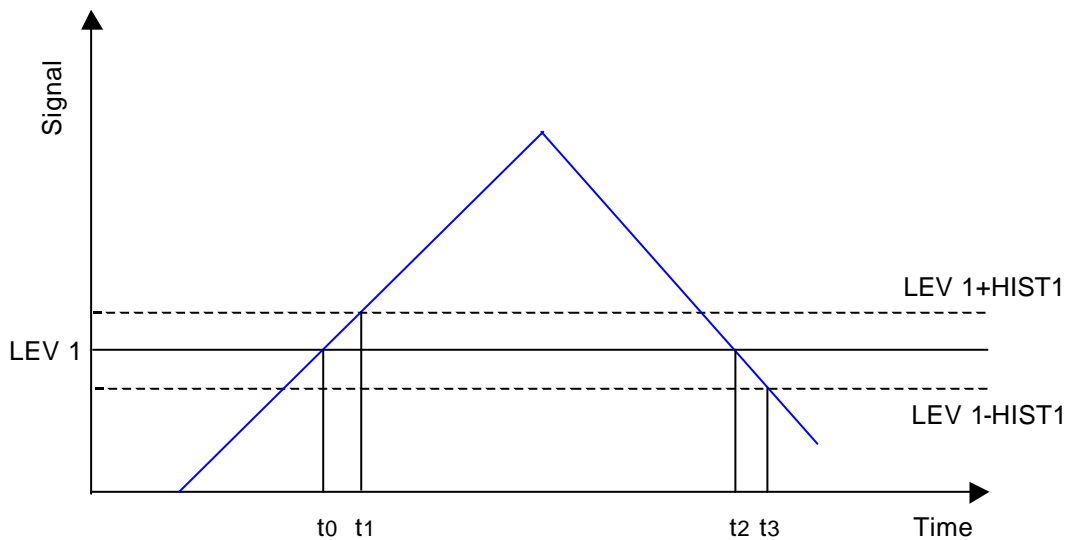

**Fig. 21** Limit Level and Hysteresis

If the hysteresis value is set to zero (HIST 1=0), when LEV 1 value is reached, the relay is activated at **t0** for increasing signal and it is deactivated at **t2** for decreasing signal.

Temporary, each relay can be individually disabled by setting to -1 the relevant hysteresis value.

When COMBINED mode of operation is not enabled (see paragraph 4.3.7), an illuminated LED on the front panel of the instrument (see paragraph 2.7) indicates that the relevant relay is activated.

If BLOCC=1 [10.19] is set in the customization menu, then limit levels values and relevant hysteresis values can also be modified in MEASURE [4] mode of operation without entering custom functions menu.

On the contrary, if BLOCC=0 threshold values and hysteresis cannot be modified in MEASURE [4] mode of operation: this way, a better protection of instrument configuration is obtained.

#### 4.3.3. FILTERING

Measurements of AN401 can be filtered in different ways which can be used separately or combined in order to sum their effects.

- a) *Digital filtering.* The effect of this RC digital filter is defined by setting the value of FILT1 [10.13] between 20 (minimum) and 250 (maximum).  
To enable this filter, set FENAB=1 [10.14]; to disable the filter set FENAB=0.  
This filter affects all measuring functions of the instrument.
- b) *Average.* By setting the value of MEAN [10.17] between 1 and 20, the number of measurements to be averaged by the instrument is defined.  
To disable this function, set MEAN=0; the function is also disabled when PEAK mode of operation is selected.  
When MEAN is enabled, display hysteresis is automatically disabled.
- c) *Display hysteresis.* By setting the value of HISTM [10.16] between 1 and 50, the minimum variation of the measured signal which will cause a display updating is defined.

*Example:* for HISTM=2, a measured value increasing from 1000 to 1001 will still be displayed as 1000; the display will be changed to 1002 when the measured value reaches 1002.

To disable the function, set HISTM=1.

*Display hysteresis* is disabled when PEAK mode is selected.

When display hysteresis is enabled, MEAN function is automatically disabled.

Display hysteresis does not affect PIECE-COUNTER mode of operation.

The use of the above filtering techniques decreases the bandwidth of the instrument.

#### 4.3.4. SERIAL TRANSMISSION RATE

Serial transmission rate can be defined by setting BAUD [10.15] value.

The following values can be defined:

BAUD [10.15] value	Serial transmission rate (baud)
0	600
1	1,200

2	2,400
3	4,800
4	9,600
5	19,200
6	38,400
7	57,600

See paragraph 3.10 for further considerations concerning characteristics of serial lines.

#### 4.3.5. SERVOINCLINOMETER CONVERSION

In systems consisting of AN401 connected to a servoinclinometer, where transducer output vs. measured tilt is a sinusoidal function, it is possible to enable a conversion algorithm which allows to display values in sexagesimal degrees.

This algorithm is enabled by the value of INCL [10.18] which defines the full scale value to be considered for the conversion; the algorithm is disabled by setting INCL=0.

INCL [10.18] value	Full scale value
0	Conversion disabled
1	14.5°
2	30°
3	45°
4	90°

After setting INCL to the full scale value of the transducer, follow calibration procedure as described in paragraph 4 to calibrate AN401 connected to a servoinclinometer.

#### 4.3.6. CHANGING LIMIT LEVELS IN MEASURE MODE

Independently from selected measuring function, when BLOCC=1 [10.19] is set, limit threshold and relevant hysteresis values can be changed pressing  $\pi$  (*up*) key.

To change the values, follow the sequence of customization menu [10] from step [10.2] (LEV1) to step [10.9] (HIST4).

All the items of the menu are in a closed loop: press  $\pi$  (*up*) pushbutton to move to next item, press  $\theta$  (*down*) pushbutton to move to previous item.

Press C (*ESC*) to escape from menu and return to measuring mode.

Each item of the menu is indicated on the display by the name of the parameter.

Press E (*Enter*) pushbutton to display present value of the parameter.

Press  $\pi$  (*up*) pushbutton to increase the value, press  $\theta$  (*down*) pushbutton to decrease the value.

At the beginning, parameter changes by units, then keeping the pushbutton pressed the parameter changes by tens and afterwards by hundreds.

Press E (*Enter*) pushbutton to store the new value and then press C (*ESC*) pushbutton to return to level setting menu; just press C (*ESC*) pushbutton without pressing E (*Enter*) pushbutton to return to level setting menu without storing the new value.

From level setting menu, press C (*ESC*) pushbutton to return to active measuring mode.

4.3.7. DISPLAY MODE

When the instrument is in MEASURE [4] mode of operation, the display mode is defined by setting MVISU [10.20] parameter.

This allows setting the instrument such that the required function is automatically selected at power-on.

MVISU [10.20] value	Measuring function
0	NET
1	GROSS
2	PIECE-COUNTER
3	ERROR
4	COMBINED DISPLAY

When COMBINED DISPLAY is set, at power-on the instrument will automatically select NET function; press  $\theta$  (down) pushbutton to move to GROSS, to PIECE-COUNTER and to ERROR functions.

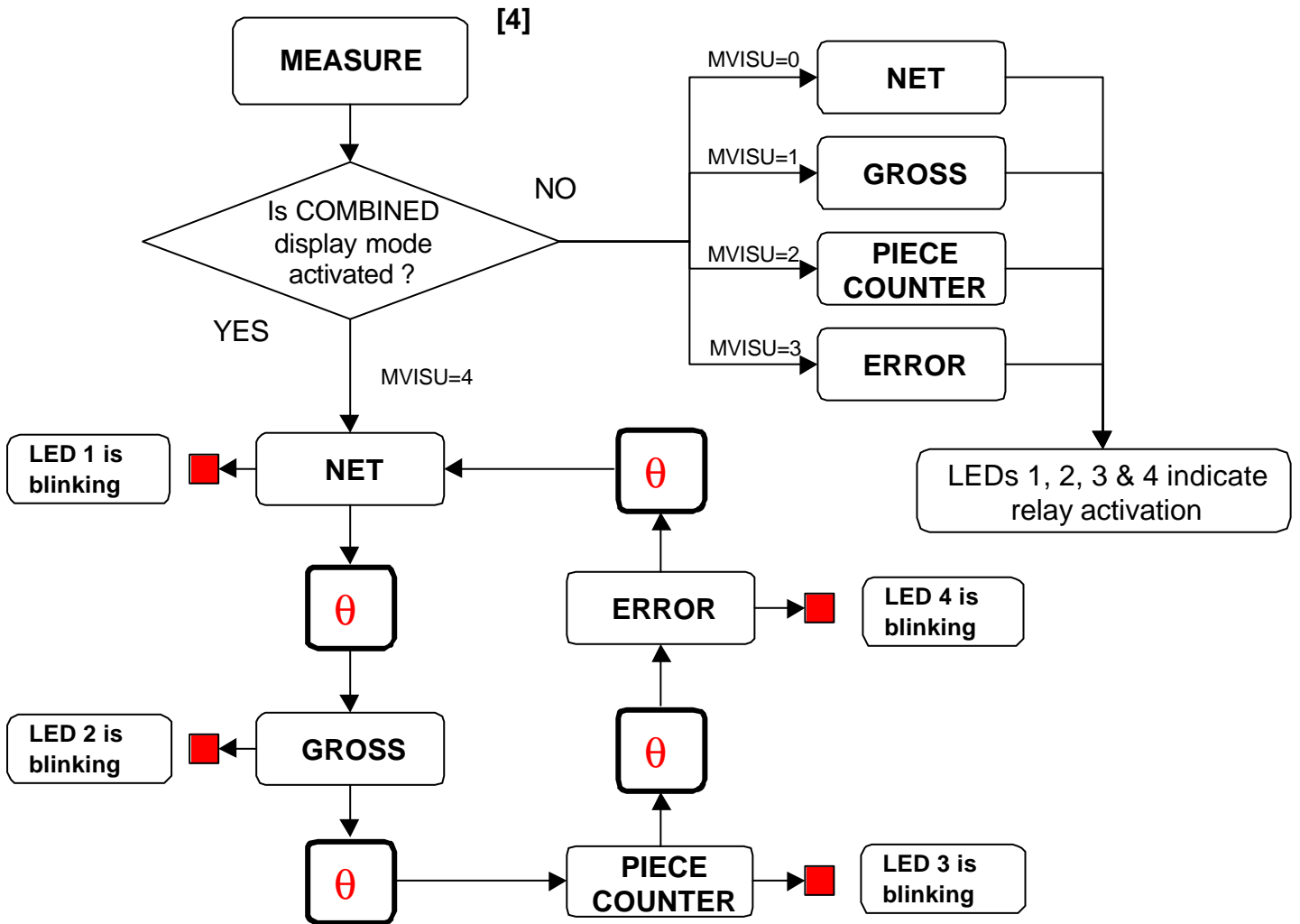

Fig. 22 Display mode

For MVISU=0 (1,2,3), LED no.0 (1,2,3) indicates that the relay associated to the relevant limit level is activated.

For MVISU=4, blinking LEDs indicate selected measuring function; in this case LEDs do not indicate activated relays.

4.3.8. TARE SETTING

Tare value can be set in mechanical units directly in the instrument by means of TAREV [10.10]. AN401 instrument provides to automatically subtract it from the measurement. After entering tare value, set TAREM=1 [10.11] to enable this function. For TAREM=0, the instrument subtracts the measured tare by means of the TARE function in the calibration menu [9.5] (see paragraph 4.2.5).

4.3.9. INSTRUMENT IDENTIFIER

When several instruments are connected to the same RS-485 serial line, it is very important to set the numerical identifier of the instrument, IDSER [10.21]. Assigning to each instrument a different numerical identifier, commands or specific measurements requests can be addressed individually to every single instrument. On the same RS-485 serial line, different numerical identifiers shall be used to avoid abnormal operations of the instruments or of the computer.

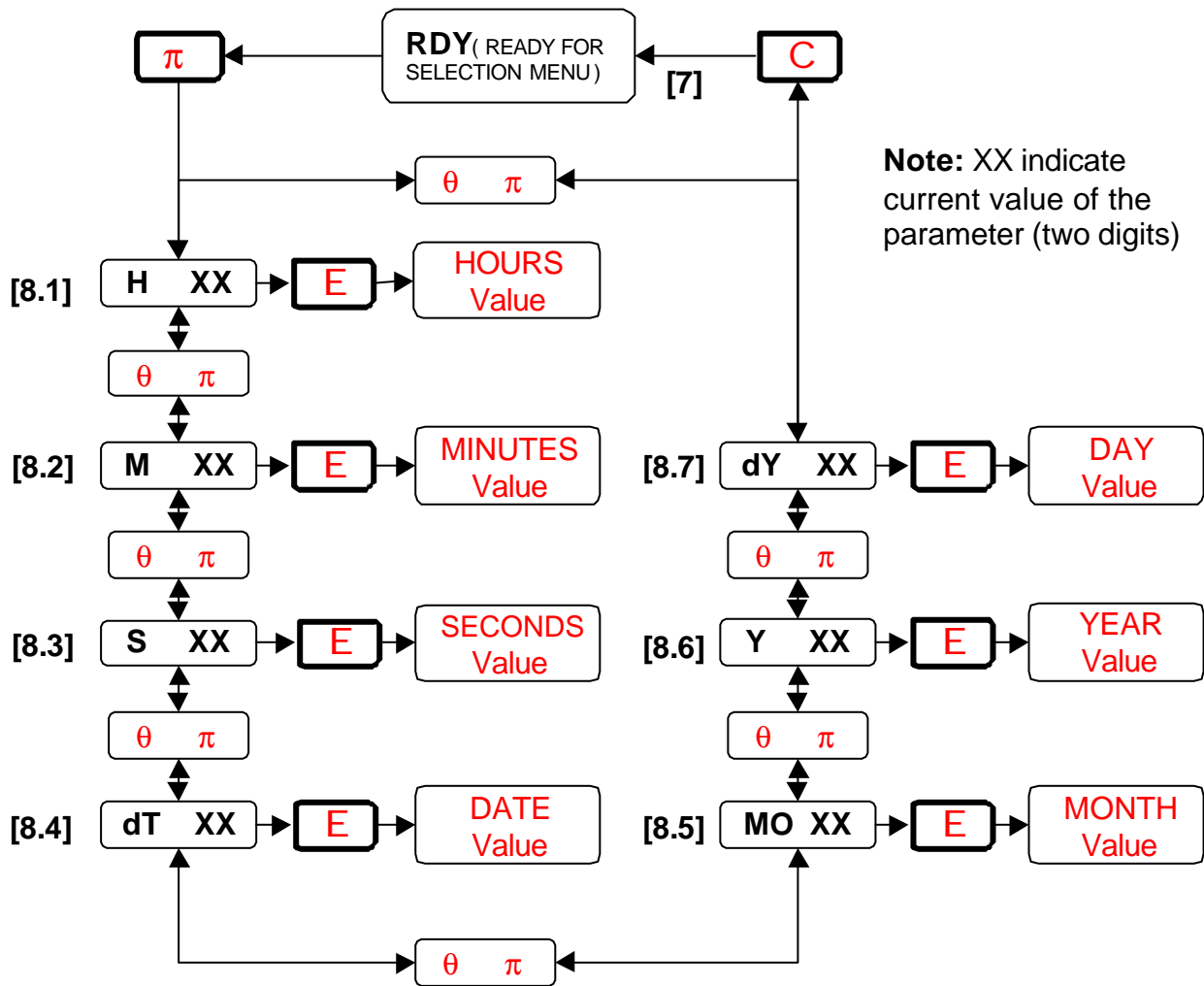

Fig. 23 Clock Setting Diagram

4.4. CLOCK MENU

If CLOCK option is installed into the instrument, clock can be set by means of CLOCK menu [8]. From RDY [7] waiting status, press π (up) pushbutton to enter this menu.

To move from one parameter to another one, and to move from [8.1] to [8.2] and up to [8.7], press  $\pi$  (*up*) pushbutton repeatedly; to move back to previous parameter, press  $\theta$  (*down*) key.

For each parameter, the indication of parameter meaning and its present value are displayed at the same time; consider, for instance, *H 00*: the first two characters on the left of the display indicate the parameter, the two digits on the right of the display indicate the value of the parameter.

In display mode, the parameter is displayed steady; the parameter is blinking to highlight that modify mode is active when *E (Enter)* pushbutton is pressed.

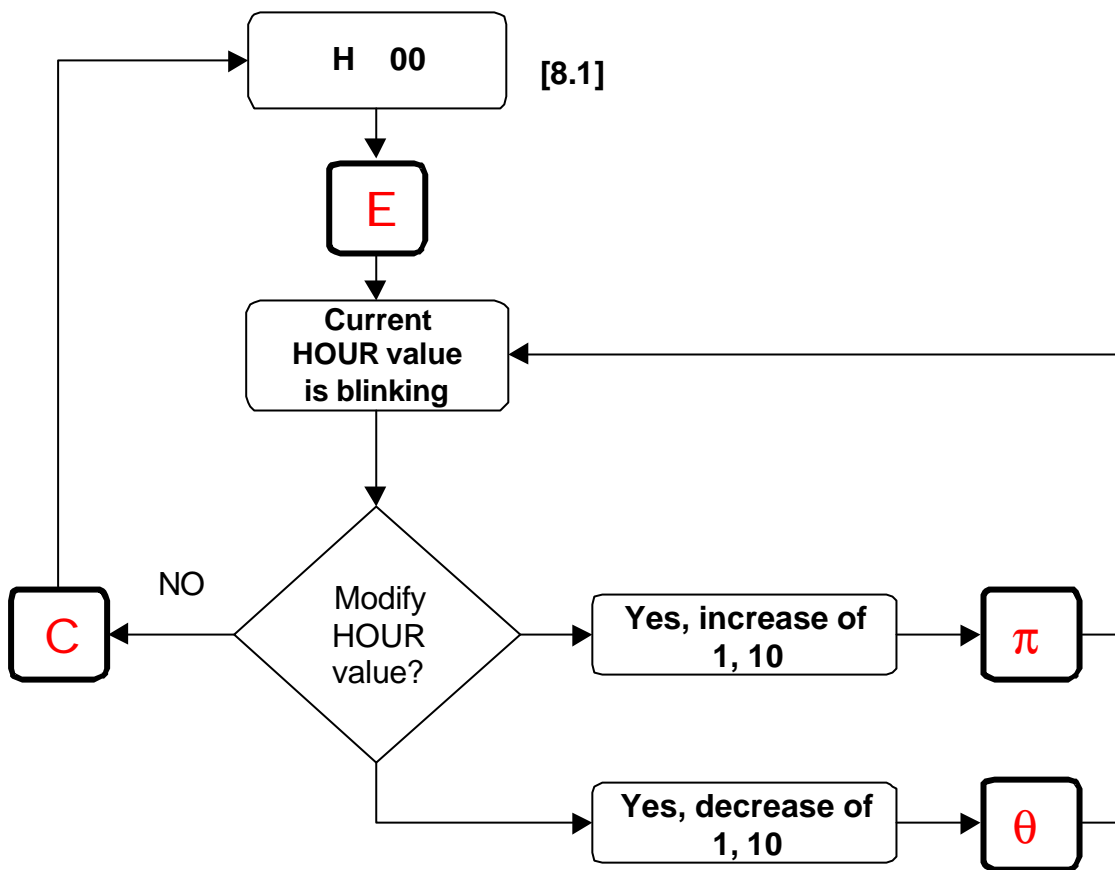

**Fig. 24** Clock Parameter Setting

The setting carried out in CLOCK menu will only have effect during printing executed by AN401 on a serial printer.

Display indication	Minimum value	Maximum value	Parameter description
H xx	0	23	<b>H</b> parameter [8.1] sets hours in 24 hours format (0=midnight)
M xx	0	59	<b>M</b> parameter [8.2] sets minutes
S xx	0	59	<b>S</b> parameter [8.3] sets seconds
dT xx	1	31	<b>dT</b> parameter [8.4] sets date
MO xx	1	12	<b>MO</b> parameter [8.5] sets month
Y xx	00	99	<b>Y</b> parameter [8.6] sets year; during printing, the instrument will change the indication to four digits: 1980 to 1999 for $80 \leq Y \leq 99$ or to 2000 to 2079 for $00 \leq Y \leq 79$
dY xx	1	7	<b>dY</b> parameter [8.7] sets day of the week (1=SUN, Sunday)

#### 4.5. **EEPROM MEMORY**

All settings concerning calibration and customization of AN401 are stored into an EEPROM memory. Also printing form is stored into this memory.

This kind of memory does not require power supply to the instrument or batteries for data retention.

Using the instrument, it is to be considered that the maximum number of memory cycles for such devices is very high, but not endless: according to Manufacturer's data, the devices are guaranteed up to 10,000 typical memory cycles.

Characteristics of EEPROM memories are more than adequate for typical applications of AN401.

It is to be noted that one memory cycle is counted each time that **E** (*Enter*) pushbutton is pressed during calibration menu [9] or customization menu [10].

The clock option is provided with its own independent memory.

## 5. MEASURING FUNCTIONS OF AN401

---

The AN401 is a microprocessor-based instrument which, in the standard version, is provided with the functions described in the following paragraphs.

Nevertheless, the instrument can be customized in different ways and additional functions can be added to it within the limits of the hardware.

The following measuring functions are described with reference to a weighing system, but their use can suit with other applications.

### 5.1. NET

In a weighing system, the measuring function NET displays the net weight applied to the transducer.

The User can subtract the tare by means of C (*ESC*) pushbutton or of KEY2 contact (see table 1).

If NET measuring mode is selected and MVISU=0, then actuation of relay contacts 1 through 4 will be indicated on the front panel by the relevant LED switched ON.

By pressing  $\theta$  (*down*), while in NET function, transducer calibration circuit is activated, if present, and provided that electrical connection allows its use.

### 5.2. GROSS

In a weighing system, the measuring function GROSS displays the gross weight applied to the transducer.

### 5.3. PIECE-COUNTER

The measuring function PIECE-COUNTER allows to display the number of pieces in a set where all pieces weigh the same, provided that a sample has been already weighted and its value stored into the instrument.

To store the weight of the sample, just press E (*Enter*) pushbutton independently from the measuring function of AN401: the instrument displays the weight of the sample until E (*Enter*) pushbutton is kept pressed and stores the value on pushbutton release.

To display the number of pieces corresponding to the weight applied to the weighing system, select PIECE-COUNTER function on the instrument (MVISU=2 or when LED 3 is blinking in COMBINED display mode).

Each time E (*Enter*) pushbutton is pressed, the instrument will store the value of the new sample deleting the previous value.

The value of the sample is stored in the volatile memory of AN401, then it will be lost after a RESET or a power down.

*Display hysteresis* has no effect when PIECE-COUNTER measuring mode is selected.

### 5.4. ERROR

ERROR measuring function displays the algebraic difference between the value measured by the instrument in NET mode and the value set as limit level no.1 (LEV 1).

This function can be used to obtain a simple dosing system.

### 5.5. **PEAK**

PEAK measuring function displays the maximum value reached by the signal after the function has been activated by rear contact KEY1 (see table 1).

This function has effect on all measuring functions at the same time; as a consequence, in combined display mode (MVISU=4), the peak value of all measuring functions can be displayed.

The contact KEY1 shall be kept closed until the display of maximum value reached by the signal is required.

To reset peak value:

- press C (*ESC*) pushbutton on the front panel of AN401 or
- close contact KEY2 on the rear panel of the instrument

Opening contact KEY1, the instrument returns to the display mode selected before activating PEAK function.

### 5.6. **HOLD**

HOLD function freezes present display value until the function is disabled.

This function freezes the display of all measuring functions of the instrument and it is enabled by means of rear contact KEY3.

The display is frozen until contact KEY3 is kept closed; opening this contact, normal operations are restored.

### 5.7. **PRINT**

The instrument can print a document consisting of a fixed form filled in with the values measured by the instrument according to available measuring functions; the instrument shall be connected to a standard serial printer (V891 type) through its serial port.

The form to be used for each print shall be loaded into EEPROM memory of the instrument before requiring the function.

The form shall be developed by means of a personal computer taking into account characteristics of the printer (as printing area, etc.) and then down loaded into the instrument using a specific procedure.

The instrument is set to manage one print form only.

To modify an existing form or to replace it, the personal computer is still necessary to develop the new form or to down load it to the AN401.

A description of the characteristics of the print form and of the commands for down load procedure is given in paragraph 6.2.5.

For development of print forms, their management and their down loading to the instrument, a software utility for Windows ® is available.

Since the print form is stored in the non-volatile memory of AN401, then it will not be lost after a RESET or a power down.

According to the value of BLOCC [10.19] parameter, PRINT function can be initiated as follows:

- for BLOCC=0, printing is initiated by means of  $\pi$  (*up*) pushbutton or by digital input KEY4.
- for BLOCC=1, printing is initiated by means of digital input KEY4 only, since  $\pi$  (*up*) pushbutton is dedicated to modify values of limit levels.

Even if  $\pi$  (*up*) pushbutton is kept pressed or contact KEY4 is kept closed continuously, only one print will be carried out by the instrument.

To get another print, release and press again  $\pi$  (*up*) pushbutton or open and close again KEY4.

## 6. SERIAL COMMUNICATION PROTOCOL

---

The AN401 can also be used from a remote computer connected to the instrument.

In this case, from the computer it is possible:

- to use the measuring functions of the instrument
- to customize the instrument
- to set the clock, if installed
- to download into the instrument the print form developed at the computer

Using the simple communication protocol embedded in the AN401, the instrument can be controlled either by means of point-to-point RS-232 serial connection (one instrument and one computer) or multi-drop RS-485 serial connection (one computer and several instruments and transducers).

During serial transmission, the function of the protocol is to ensure integrity of transmitted data (commands, measurement values or instrument responses).

All the above operations are carried out establishing a communication link between the computer and the instrument through a set of commands. Commands shall be part of an ASCII command string with a well-defined format.

### 6.1. PROTOCOL FORMAT

The protocol foresees two different formats for the messages to be sent to AN401:

- a format for generic commands;
- a format for instrument configuration commands (these commands are relevant to customization menu [10] ).

#### 6.1.1. COMMAND MESSAGE FORMAT

The format of command messages from computer to AN401 is as follows:

- a) Any *command* shall begin with the character @ which signals the beginning of the message. The character @ is equivalent to an ASCII character and will always be placed in the first position of the message format.
- b) Character @ shall be followed by the identifier **ID** of the instrument to which the command is addressed. The identifier shall be a character in the set **0-9** or **A-Z**; ID can also be the character ? if a message is to be sent to an instrument the identifier of which is unknown.

With RS-485 multi-drop serial lines (several instruments connected to the same serial line), the character ? can be used only if one instrument at a time is connected to the serial line: this is to avoid that more than one instrument can respond at the same time to the computer causing a conflict situation.

Typically, the character ? is used to establish a connection with an instrument without identifier so that the computer can assign an identifier to it.

An ASCII character is used for the identifier and it will always be placed in the second position of the message format.

- c) ID shall be followed by a character corresponding to the command to be sent to the instrument.  
This ASCII character will always be placed in the third position of the message format. A description of available commands is given in paragraph 6.2.
- d) Command character shall be followed by the argument of the command, if any; this consists of one or more ASCII characters starting from the fourth position of the message format.
- e) Any message shall always be terminated by **CR** (Carriage Return) which corresponds to a character of ASCII code.

**COMMAND MESSAGE FORMAT**

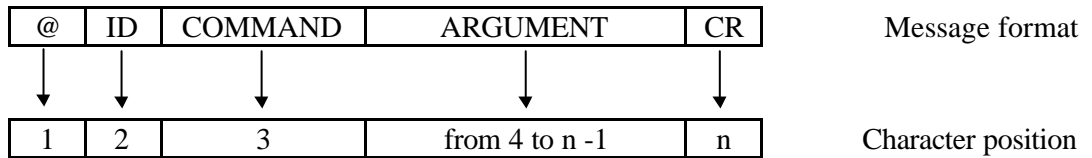

6.1.2. CONFIGURATION MESSAGE FORMAT

The *message* for instrument configuration is a special type of command where the command is the character **S** followed by the additional indication of the parameter to be modified (this is a numerical indication).

The format of configuration messages from computer to AN401 is as follows:

- a) Any message shall begin with the character @ which signals the beginning of the message. The character @ is equivalent to an ASCII character and will always be placed in the first position of the message format.
- b) Character @ shall be followed by the identifier **ID** of the instrument to which the command is addressed. The identifier shall be a character in the set **0-9** or **A-Z**; ID can also be the character ? if a message is to be sent to an instrument the identifier of which is unknown.  
With RS-485 multi-drop serial lines (several instruments connected to the same serial line), the character ? can be used only if one instrument at a time is connected to the serial line: this is to avoid that more than one instrument can respond at the same time to the computer causing a conflict situation.  
Typically, the character ? is used to establish a connection with an instrument without identifier so that the computer can assign an identifier to it.  
An ASCII character is used for the identifier and it will always be placed in the second position of the message format.
- c) ID shall be followed by character **S** corresponding to the command for parameter modification.  
This ASCII character will always be placed in the third position of the message format.
- d) **S** command shall be followed by a two digits number identifying the parameter to be modified.  
Should the parameter be a number between 0 and 9, then a zero shall be put in front of the number as a prefix (00, 01, ..., 09).
- e) The two digits number shall be followed by the value of the parameter to be modified. It shall always consist of five ASCII characters with a preceding minus sign in case of negative values.

Parameters can be in the range from -99999 to +99999.

Negative values shall be indicated by minus sign (-99999 or -09999), while + sign shall not be put in front of positive values (99999 or 00123).

- f) Any message shall always be terminated by **CR** (Carriage Return) which corresponds to a character of ASCII code.

### CONFIGURATION MESSAGE FORMAT

@	ID	S	XX	PARAMETER VALUE	CR
---	----	---	----	-----------------	----

Message format

## 6.2. AVAILABLE COMMANDS

**Note:** commands received by the AN401 are accepted whether upper or lower case character is used for the command.

*It is important to remind that the instrument accepts commands received on the serial line only if MEASURE [4] mode is selected. Should calibration or customization modes [5], [6], [7], [8], [9], [10] be selected, commands sent on the serial line will be ignored by the instrument.*

Available commands are described in the following paragraphs; it is supposed to be connected to an instrument with the identifier **ID=0**.

### 6.2.1. "C" COMMAND

"**C**" command stores into AN401 the weigh of the sample which is used for PIECE-COUNTER measuring function. This command does not change the display of the instrument since the value of the net weight of the sample is not displayed.

*Example:*

@	0	C	CR
---	---	---	----

The instrument will send the character **!** back to the computer to confirm execution of the received command.

### 6.2.2. "G" COMMAND

"**G**" command allows the computer to read the set value of a custom parameter of the instrument.

*Example:*

@	0	G	01	CR
---	---	---	----	----

In the above example, the instrument is requested to send the current value of limit level 1 (LEV1) to the computer.

The instrument will send the required value back to the computer to confirm execution of the received command.

### 6.2.3. "H" COMMAND

"**H**" command allows computer to set or to read clock parameters (hour, date, etc.) when the clock option is installed. This command is carried out sending a message with a well defined format containing all necessary information.

The format of the message shall be as follows:

**XGDDMMAAHHTTSS**

where:

- X determines whether clock parameters is to be set (X=0) or clock parameters reading is required (X=1).
- G sets the day of the week; G is a number between 1 and 7, where G=1 means Sunday.  
The print of the day of the week is abbreviated, then for G=1=Sunday "SUN" is printed.
- DD sets the date; DD is a number between 1 and 31; single digit numbers shall be preceded by 0 since this field requires two ASCII characters, then put DD=06 instead of "6".
- MM sets the month; MM is a number between 1 and 12; single digit numbers shall be preceded by 0 since this field requires two ASCII characters, then put MM=06 instead of "6".
- AA sets the year; AA is a number between 80 and 99.  
During printing, the instrument will change the indication to four digits:  
1980 to 1999 for  $80 \leq AA \leq 99$   
2000 to 2079 for  $00 \leq AA \leq 79$
- HH sets hours; HH is a number between 0 and 23; single digit numbers shall be preceded by 0 since this field requires two ASCII characters, then put HH=06 instead of "6". HH=0 means midnight.
- TT sets minutes; TT is a number between 0 and 59; single digit numbers shall be preceded by 0 since this field requires two ASCII characters, then put TT=06 instead of "6".
- SS sets seconds; SS is a number between 0 and 59; single digit numbers shall be preceded by 0 since this field requires two ASCII characters, then put SS=06 instead of "6".

*Example 1:*

@	0	H	04150798143521	CR
---	---	---	----------------	----

In the above example, the instrument will be set as follows:

day of the week:       Wednesday  
date:                   15/07/98  
current time:         14:35:21

*Example 2:*

@	0	H	1	CR
---	---	---	---	----

In the above example, the instrument is requested to send current values of clock parameters to the computer.

The instrument will send the required values back to the computer by means of a message starting with **RTC** and according to the following format:

**RTCGDDMMAAHHTTSS**

The meaning of these fields is the same as described hereinbefore.

6.2.4. “INIT” COMMAND

“INIT” command allows computer to reset the instrument initiating the power-on sequence of fig. 16.

This command shall follow a change of full scale value (FS [10.1]), which is used to convert conversion points of A/D converter into mechanical units, or a change on the baud rate value (BAUD [10.15]).

After saving the modified value, the command initiates a complete reset of the instrument including calculation of the new conversion coefficient.

Example: 

@	0	INIT	CR
---	---	------	----

6.2.5. “K” COMMAND

“K” command presets the instrument to receive ASCII strings corresponding to the text to be printed; each string corresponds to a line of the text.

Strings shall be compatible to available printing area of the printer: this shall be checked by whom defines the strings.

The set of strings cannot exceed 1,500 total characters (bytes).

Example: 

@	0	K	CR
---	---	---	----

Strings can include:

- *fixed text*, i.e. headings or other text common to each print.
- *data fields*, i.e. the fields for the values resulting from AN401 different measuring functions.

Data fields are “bookmarks” to be placed in the fixed text: the instrument will replace bookmarks with values resulting from measuring functions.

In the text, each bookmark takes the same number of characters as the value to be printed.

Function	Data field bookmarks	Characters number	Example
NET	!NNNNNN	7	+5.2376
GROSS	!GGGGGG	7	-726.79
PIECE-COUNTER	!PPPPPP	7	+15000
ERROR	!EEEEEE	7	-60.571
PEAK	!XX	3 max	ON or OFF
DATE	!DDDDDDDDDDDDDD	14	Sun_12/09/1998
HOUR	!HHHHHHH	8	10:11:23

- sequence of control characters for the printer, if any
- Carriage Return (CR) and/or Line Feed (LF)

String receiving mode will be ended on receiving character CHR\$(0) (NUL, ASCII code 0x00).

Example (applicable to printers without automatic line feed):

<u>Strings sent to AN401</u>	<u>Corresponding printing</u>
@0KCR	
Measured net weight:!NNNNNN CRLF CRLF	Measured net weight:+5.2376
No. of parts on scale:!PPPPPP CRLF CRLF	No. of parts on scale:+15000
Date:!DDDDDDDDDDDDDD CRLF	Date:Sun 12/09/1998
Error:!EEEEEE Peak:!XX CRLF	Error:-60.571 Peak:OFF
CHR\$(0)	

### 6.2.6. “L” COMMAND

“L” command allows computer to close calibration contact inside the instrument. This is the same contact controlled by HICAL [9.4] function in calibration menu of AN401; it can be used to check operation of the measuring chain. When the contact is remotely controlled by the computer, it cannot be used to calibrate the instrument: calibration can be carried out exclusively by means of the instrument itself. For L=1, the contact is closed; it remains closed until a new command string with L=0 is received.

*Example 1:*

@	0	L	1	CR
---	---	---	---	----

*Example 2:*

@	0	L	0	CR
---	---	---	---	----

In the above examples, calibration contact is closed on receiving the string of example 1; it is then opened on receiving the string of example 2.

### 6.2.7. “P” COMMAND

“P” command allows computer to enable and to disable the peak function; also resetting of current peak value can be achieved by this command. The argument of command “P” is an ASCII character which can take the following values:

- P=0 to disable peak function

*Example 1:*

@	0	P	0	CR
---	---	---	---	----

- P=1 to enable peak function

*Example 2:*

@	0	P	1	CR
---	---	---	---	----

- P=2 to reset peak value

*Example 3:*

@	0	P	2	CR
---	---	---	---	----

### 6.2.8. “R” COMMAND

“R” command allows computer to read the value measured by AN401; the measuring function is selected setting the value of command argument.

This command is executed independently from the current measuring mode of the instrument at the time the command is sent from the remote computer.

The argument of command “R” is an ASCII character, which can take the following values:

- R=0 to read NET value from the instrument

*Example 1:*

@	0	R	0	CR
---	---	---	---	----

- R=1 to read GROSS value from the instrument

*Example 2:*

@	0	R	1	CR
---	---	---	---	----

- R=2 to read PIECE-COUNTER value from the instrument

*Example 3:*

@	0	R	2	CR
---	---	---	---	----

- R=3 to read ERROR value from the instrument

*Example 4:*

@	0	R	3	CR
---	---	---	---	----

### 6.2.9. “V” COMMAND

“V” command allows computer to read the firmware revision installed in the instrument.

*Example:*

@	0	V	CR
---	---	---	----

On receiving this command, the instrument will send an ASCII string back to the computer: this string includes firmware version, date of reference and serial number of the instrument .

### 6.2.10. “Z” COMMAND

“Z” command allows computer to enable “zero” function of the instrument, i.e. an offset equal to value measured at the time of the command is subtracted from measurement: as a consequence, the difference between the measured value and the offset is displayed by AN401 and send back to computer following command R=0.

*Example:*

@	0	Z	CR
---	---	---	----



### 6.3. CUSTOMIZATION PARAMETERS

The meaning of these parameters and their range of values are given in paragraph 4.3.

#### CONFIGURATION MESSAGE FORMAT

@	ID	S	XX	PARAMETER VALUE	CR
---	----	---	----	-----------------	----

Message format

Argument of S command	AN401 Parameter	Description
00	<b>FS</b> [10.1]	To set the value of full scale (FS)
01	<b>LEV 1</b> [10.2]	To set the value of limit level no. 1
02	<b>HIST 1</b> [10.3]	To set the value of hysteresis for level no. 1
03	<b>LEV 2</b> [10.4]	To set the value of limit level no. 2
04	<b>HIST 2</b> [10.5]	To set the value of hysteresis for level no. 2
05	<b>LEV 3</b> [10.6]	To set the value of limit level no. 3
06	<b>HIST 3</b> [10.7]	To set the value of hysteresis for level no. 3
07	<b>LEV 4</b> [10.8]	To set the value of limit level no. 4
08	<b>HIST 4</b> [10.9]	To set the value of hysteresis for level no. 4
09	<b>TAREV</b> [10.10]	To set the known value of the tare
10	<b>TAREM</b> [10.11]	To select the type of tare to be used
11	<b>DP</b> [10.12]	To set the position of decimal point
12	<b>FILT 1</b> [10.13]	To set the value of the digital filter
13	<b>FENAB</b> [10.14]	To enable digital filter
14	<b>BAUD</b> [10.15]	To set the baud rate of serial transmission
15	<b>HISTM</b> [10.16]	To set hysteresis applicable to the display
16	<b>MEAN</b> [10.17]	To set the average
17	<b>INCL</b> [10.18]	To set the conversion for servoinclinometers
18	<b>BLOCC</b> [10.19]	To enable/disable level menu in measure mode
19	<b>MVISU</b> [10.20]	To set display mode of the measure
20	<b>IDSER</b> [10.21]	To set serial identifier of the instrument

*Example 1:*

@	0	S	00	01500	CR
---	---	---	----	-------	----

The string of example 1 will set full scale value (FS) to 1500.

*Example 2:*

@	0	S	03	-01000	CR
---	---	---	----	--------	----

The string of example 2 will set limit level 2 to -1000.

*Example 3:*

@	0	S	11	00003	CR
---	---	---	----	-------	----

The string of example 3 will set decimal point to position 3.

#### 6.4. *RESPONSES FROM AN401*

According to the received command and to the context, the instrument will always send back a response to computer; the response consists of the following strings.

<b>AN401 Response</b>	<b>Description</b>
<b>!</b>	Response to an accepted and executed command
<b>?</b>	Response to an unknown command or to an incorrect format
<b>Nxxxxxx</b>	Response to command G requiring parameter value; xxxxxx corresponds to the required value including sign and decimal point
<b>Vnnnnn</b>	Response to command R0 requiring NET value; nnnnn corresponds to the required value including sign and decimal point
<b>Lnnnnn</b>	Response to command R1 requiring GROSS value; nnnnn corresponds to the required value including sign and decimal point
<b>Pnnnnn</b>	Response to command R2 requiring PIECE-COUNTER value; nnnnn corresponds to the required value including sign and decimal point
<b>Ennnnn</b>	Response to command R3 requiring ERROR value; nnnnn corresponds to the required value including sign and decimal point

## 7. CE MARKING

---

To certify the AN401 according to the requirements of electromagnetic compatibility specifications, all useful hardware and software solutions have been implemented in the instrument.

Nevertheless, it is to be considered that the specific application where the instrument is installed can differ from the conditions simulated during EMC testing.

Therefore, the set of installation and wiring conditions minimizing the effects of electromagnetic interference shall be found out for each application; specific cares shall be given to:

- the analog signal from the transducer
- power supply to the instrument
- digital signals (TTL, RS-232 or RS-485)

All the above mentioned signals can be affected by noise or can propagate noise into the instrument.

### 7.1. ELECTROMAGNETIC INTERFERENCE PROTECTION

The following considerations are general suggestions which can be effective depending on the amount and kind of noise: they shall not be considered the only suitable solutions to protect the instrument.

*Some cares* to be taken in the interconnection between AN401 and transducer are as follows:

- Always use cables with 100% shield for the wiring between the instrument and the transducer.
- Transducer and its interconnecting cable shall be placed far from electric motors, power switches, electric actuators, etc.
- Cables shall be placed into reserved pipes.
- Generally, shield should be isolated from transducer body; shield should be earthed at instrument side (see paragraph 3.2.9); if shielding is inadequate, the cable shall be passed through a common iron tube (paramagnetic with low carbon content for best electromagnetic shielding) earthed near or together with the transducer.

**Note:** cable shield and shielding tube shall be provided with isolating sheaths to avoid leakage current due to accidental electric contact to metallic structures.

- If the cable is provided with plug connectors, shields shall be connected through electric contacts: never use the shell of the connector which shall be coated with insulating tape after execution of interconnection.
- Avoid connections to earth network of factories since they are always source of noise: use separate earth connections.  
Each system shall be connected to earth with a separate earth wiring; all earth wirings shall be tied to a single earth point at true null potential (“star” topology); avoid to connect different system to the same earth wiring.
- If necessary, it could be useful to connect earth terminal of AN401 as described in paragraph 3.2.9: this way, by-pass filters of the instrument are activated.
- Additionally, the instrument can be installed into a metallic case connected to earth.

**Important notice: always comply with all rules in use concerning earthing.**

Some cares to be taken in the interconnection between AN401 and power supply are as follows:



To comply with CE marking, a ferrite coil (e.g. model MEC MSFC-5T) shall be placed in the power supply cable near to rear panel of the instrument; the cable shall pass through the ferrite forming a one turn coil with 170 ohm impedance at 25 MHz.

In the following picture, a view of the ferrite one turn coil is given; as per the diagram hereinafter, the turn consists of both wires.

If necessary, it could be useful to connect earth terminal of AN401 as described in paragraph 3.2.9: this way, by-pass filters of the instrument are activated.

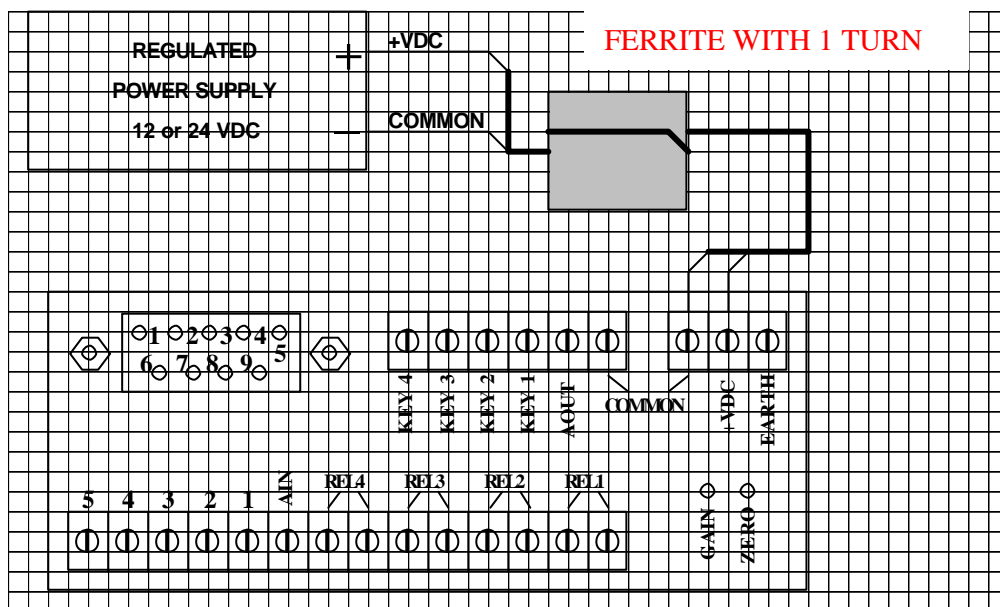

Some cares to be taken in the interconnection between AN401 and digital signals are as follows:

It is recommended to use shielded twisted pairs since their immunity to noise is greater than non-shielded cables.

Moreover, if necessary, use double shielded interconnecting cables.

To obtain the best immunity to noise, paramount cares should be taken in earthing the interconnecting cable. It shall be connected such that ground loops, which could allow noise current to flow, are avoided. For shielding effectiveness, the User shall also check that the earthing point be a true reference point at null electrical potential.

If double shielded cables are used, it is suggested that inner shield be connected at one side (e.g. the AN401) and the outer shield be connected at the opposite side (e.g. the computer).

If necessary, it is also possible to consider the use of optocouplers for serial lines.

TTL inputs of terminals KEY1, KEY2, KEY3, KEY4 are provided with digital software filter for debouncing.

## 7.2. TEST LABORATORY AND TEST LIST

Tests have been carried out at a **test laboratory** internationally recognized as “**competent body**”.

The instrument has been submitted to the most severe compatibility tests applicable to industrial applications, i.e. **EN 50081-2 (for emissions)** and **EN 50082-2 (for susceptibility)**.

In details, they consist of:

- 1) *Normative reference: EN 55011*: Test category: Emission; Port: enclosure; Type of test: radiated interference field strength; Frequency range: 30 to 1,000 MHz Class: A (ISM).
- 2) *Normative reference: ENV 50140*: Port: enclosure; Test category: Immunity; Type of test: radiated radio-frequency, electro-magnetic field; Frequency range: 80 to 1,000 MHz; Test level: 10 V/m.
- 3) *Normative reference: ENV 50141*: Port: DC I/O power port; Test category: Immunity; Type of test: RF common mode; Frequency range: 0.15 to 80 MHz; Test level: 10 V.
- 4) *Normative reference: ENV 50141*: Port: signal lines; Test category: Immunity; Type of test: RF common mode; Frequency range: 0.15 to 80 MHz; Test level: 10 V.
- 5) *Normative reference: EN 61000-4-4*: Port: DC I/O power port; Test category: Immunity; Type of test: Fast transient (burst). Common mode; Test level: 3.
- 6) *Normative reference: EN 61000-4-4*: Port: signal lines; Test category: Immunity; Type of test: Fast transient (burst). Common mode; Test level: 3.
- 7) *Normative reference: EN 61000-4-2*: Port: Enclosure; Test category: Immunity; Type of test: ESD; Test level:  $\pm 4$  kV.
- 8) *Normative reference: EN 61000-4-8*: Port: Enclosure; Test category: Immunity; Type of test: Power frequency magnetic field; Frequency range: 50 Hz; Test level: 4.
- 9) *Normative reference: ENV 50204*: Port: Enclosure; Test category: Immunity; Type of test: Radio frequency electromagnetic field. Pulse modulated: 900+5 MHz; Test level: 3.

## 7.3. TEST RESULTS AND CONFIDENTIAL INFORMATION

**All the tests have been passed successfully.**

Documents and test results shall be considered as confidential information according to test laboratory and CE norms.

Therefore, they cannot be published, nor photocopied: they can be consulted at our *Factory by an appointed competent body only*.

## **8. TERMS OF SALE**

---

(These terms of sale are applicable to all DS Europe Products)

### **8.1. LIMITED WARRANTY**

Several electrical and mechanical tests carried out during manufacturing process and the final test carried out on each unit warrant that delivered Product is free from defects in materials, workmanship and performance. During the warranty period of six months from delivery, at no additional charge, Product rendered defective under normal use will be repaired or replaced at DS Europe factory.

The Product shall be forwarded at Buyer's expense concerning shipping, insurance, customs duties or any other charges associated with transportation of the Product.

This Limited Warranty does not extend to any Product that has been damaged or rendered defective as a result of accident, misuse, or abuse.

Moreover, in case of heavy or non-reparable damages, the Product may be rendered disassembled to the Buyer if the cost to re-assemble the Product will not be paid.

The Product contains firmware that is provided on an "AS IS" basis: essentially, firmware is in accordance with the description of the Product manual.

Except as expressly set forth in this warranty, DS Europe makes no other warranties, expressed or implied, including any implied warranties of merchantability and fitness for a particular purpose, concerning hardware and firmware of the Product and its relevant documentation.

This Limited Warranty does not extend to any semiconductors: integrated circuits, transistors, diodes, microprocessors, memories and whatever else not covered by semiconductor Manufacturers' warranty.

The Buyer shall check the delivered Product within 10 days from receipt; after this limit, the Product shall be considered accepted.

DS Europe liability is limited to the above; DS Europe is not liable for any personal injuries, damages to property or damages due to stoppage of machinery or plants caused by installation and use of supplied Product (including, without any limits, any lost profits, lost savings, stoppage of activities, lost information or any other economic losses).

### **8.2. LIABILITY FOR DAMAGES**

DS Europe products are parts of more complex systems and plants; these are sold in thousands per year, for thousands different applications with thousands of norms and precautions concerning installation and use that are not known to the Manufacturer.

In case of installation or use that can directly or indirectly cause personal injuries, damages to property or damages due to stoppage of machinery or plants, before installation the Buyer shall immediately advise DS Europe that will stop purchase negotiation or suspend deliveries of the Product.

However, to minimize or to avoid risk of damages, DS Europe is available, without any responsibility, to suggest solutions and protection accessories, test certifications, competent Bodies or consultant Institutes.

Moreover, it is recommended to read carefully installation and use instructions attached to Product delivery. These instructions can also be sent during purchase negotiation on Buyer's request.

#### **NOTICE:**

Even if not expressly mentioned, these "Terms of Sale" are integral and complementary part of any bulletin, invoice or instruction manual.

DS EUROPE S.R.L.

Terms of Sale no. 140998 of September 14th, 1998.